

15 -ാം കേരള നിയമസഭ

10 -ാം സമ്മേളനം

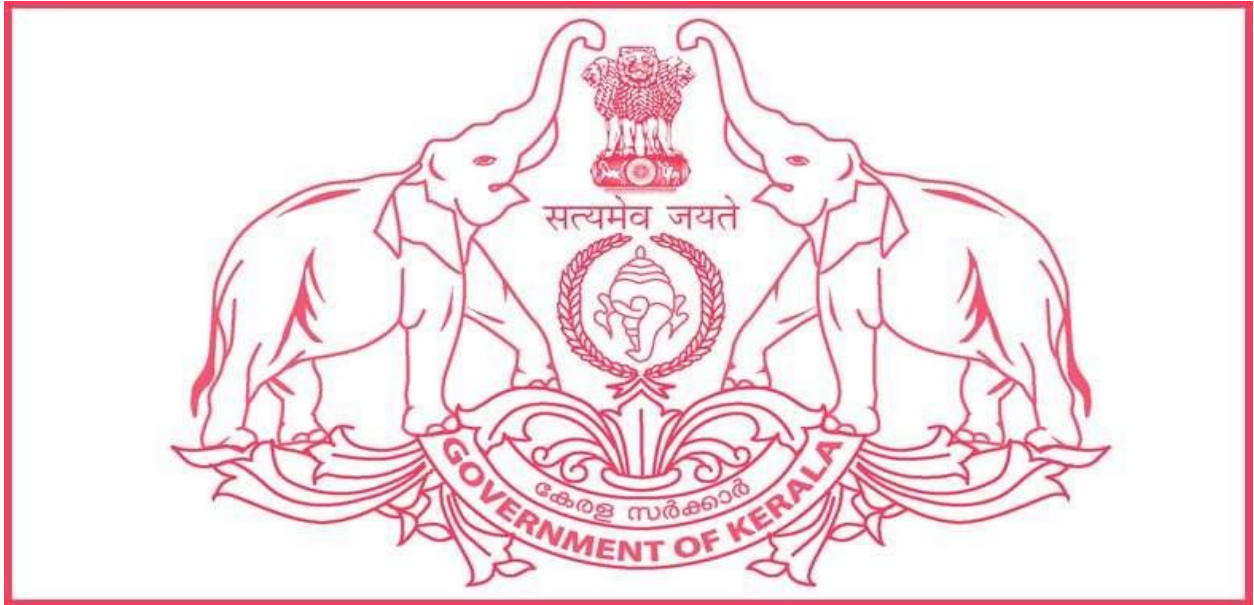
നക്ഷത്ര ചിഹ്നം ഇല്ലാത്ത ചോദ്യം നം. 2131

12-02-2024 - ൽ മറുപടിയ്ക്ക്

കെ-ഫോൺ പദ്ധതി

ചോദ്യം		ഉത്തരം	
ശ്രീ. എൽദോസ് പി. കുനപ്പിള്ളിൽ		ശ്രീ. പിണറായി വിജയൻ (മുഖ്യമന്ത്രി)	
(എ)	കെ-ഫോൺ പദ്ധതിയുടെ ഭാഗമായി ബെൽ കൺസോർഷ്യത്തിന് ലഭിച്ച കരാറിന്റെ ടെൻഡർ ആർ.എഫ്.പി.യുടെ പകർപ്പ് നൽകാമോ; അറിയിക്കുമോ?	(എ)	ആർ.എഫ്.പി.യുടെ (വോളം 1 ഉം 2 ഉം) പകർപ്പ് അനുബന്ധമായി ഉള്ളടക്കം ചെയ്യുന്നു.

സെക്ഷൻ ഓഫീസർ



**Request for Proposal  
for  
Selection of an Agency for Implementation of  
Kerala Fibre Optic Network &  
Reliable Communication and Data Acquisition Network**

Tender Ref No: KSITIL/MD/KFON/18/1852

**Volume - I  
Instructions to Bidders  
June 2018**

**Published by  
Kerala State Information Technology Infrastructure Ltd.**

*TC No.: 14/196/2, 3rd Floor,  
Chandrasekharan Nair Stadium,  
Palayam, Trivandrum - 695033*

## **DISCLAIMER**

The information contained in this Tender or subsequently provided to Applicants, whether verbally or in documentary or any other form by or on behalf of the Authority or any of its employees or advisers, is provided to Applicants on the terms and conditions set out in this Tender and such other terms and conditions subject to which such information is provided.

This Tender is issued by the Managing Director, Kerala State IT Infrastructure Ltd on behalf of Kerala Fibre Optic Network Ltd. This Tender is not an agreement and is neither an offer nor invitation by the Authority to the prospective Applicants or any other person. The purpose of this Tender is to provide interested parties with information that may be useful to them in the formulation of their Bid pursuant to this Tender. This Tender includes statements, which reflect various assumptions and assessments arrived at by the Authority in relation to solution for Kerala Fibre Optic Network and Reliable Communication and Data Acquisition Network. Such assumptions, assessments and statements do not purport to contain all the information that each Applicant may require. This Tender may not be appropriate for all persons, and it is not possible for the Authority, its employees or advisers to consider the objectives, technical expertise and particular needs of each party who reads or uses this Tender. The assumptions, assessments, statements and information contained in this Tender, may not be complete, accurate, adequate or correct. Each Applicant should, therefore, conduct its own investigations and analysis and should check the accuracy, adequacy, correctness, reliability and completeness of the assumptions, assessments and information contained in this Tender and obtain independent advice from appropriate sources.

Information provided in this Tender to the Applicants is on a wide range of matters, some of which depends upon interpretation of law. The information given is not an exhaustive account of statutory requirements and should not be regarded as a complete or authoritative statement of law. The Authority accepts no responsibility for the accuracy or otherwise for any interpretation or opinion on the law expressed herein.

The Authority, its employees and advisers make no representation or warranty and shall have no liability to any person including any Applicant under any law, statute, and rules or regulations or tort, principles of restitution or unjust enrichment or otherwise for any loss, damages, cost or expense which may arise from or be incurred or suffered on account of anything contained in this Tender or otherwise, including the accuracy, adequacy, correctness, reliability or completeness of the Tender and any assessment, assumption, statement or information contained therein or deemed to form part of this Tender or arising in any way in this selection process.

The Authority also accepts no liability of any nature whether resulting from negligence or otherwise however caused arising from reliance of any Applicant upon the statements contained in this Tender. The Authority may in its absolute discretion, but without being under any obligation to do so, update, amend or supplement the information, assessment or assumption contained in this Tender. The issue of this Tender does not imply that the Authority is bound to select an Applicant or Applicants, as the case may be, for the implementation of Kerala Fibre Optic Network and Reliable Communication and Data Acquisition Network and the Authority reserves the right to reject all or any of the Proposals without assigning any reason whatsoever.

The Applicant shall bear all its costs associated with or relating to the preparation and submission of its Proposal including but not limited to preparation, copying, postage, delivery fees, expenses associated with any demonstrations or presentations which may be required by the Authority or any other costs incurred in connection with or relating to its Proposal. All such costs and expenses will remain with the Applicant and the Authority shall not be liable in any manner whatsoever for the same or for any other costs or other expenses incurred by an Applicant in preparation or submission of the Bid, regardless of the conduct or outcome of the selection process.

# Table of Contents

<b>DISCLAIMER.....</b>	
<b>TABLE OF CONTENTS.....</b>	
<b>DEFINITIONS .....</b>	
<b>1 BIDDING DATA SHEET .....</b>	
<b>2 INSTRUCTION TO BIDDERS .....</b>	
2.1 PROCUREMENT UNDER KERALA FIBRE OPTIC NETWORK.....	10
2.2 DUE DILIGENCE .....	10
2.3 COST OF BIDDING .....	10
2.4 LANGUAGE OF THE BID .....	10
2.5 PRE-BID MEETING & CLARIFICATIONS .....	10
2.6 AMENDMENT OF THE TENDER DOCUMENT.....	11
2.7 COMPLIANCE/COMPLETENESS OF THE BID.....	11
2.8 DOCUMENTS COMPRISING THE BID.....	11
2.8.1 <i>Pre-Qualification Bid</i> .....	
2.8.2 <i>Technical Bid</i> .....	
2.8.3 <i>Commercial Bid</i> .....	
2.9 SUBMISSION OF HARD COPY OF PRE-QUALIFICATION AND TECHNICAL BID DOCUMENTS .....	12
2.10 HAND WRITTEN DOCUMENTS, ERASURES OR ALTERATIONS .....	13
2.11 BID SECURITY/EARNEST MONEY DEPOSIT (EMD).....	13
2.12 VARIATION OF QUANTITY .....	13
2.13 BID PRICES .....	13
2.14 FIRM PRICES.....	13
2.15 INSPECTION OF SITE AND SUFFICIENCY OF TENDER .....	14
2.16 CONDITIONAL BIDS BY THE BIDDERS .....	14
2.17 LATE TENDER BIDS.....	14
2.18 BID VALIDITY PERIOD .....	14
2.19 OPENING OF BIDS.....	14
2.20 CLARIFICATION OF BIDS.....	14
2.21 RIGHT TO ACCEPT ANY BID AND REJECT ANY OR ALL BIDS.....	14
2.22 NOTIFICATION OF AWARD.....	14
2.23 PERFORMANCE SECURITY (PS) .....	15
2.24 SIGNING OF CONTRACT .....	15
2.25 INTEGRITY PACT .....	15
2.26 IT ACT 2008.....	15
2.27 CONCESSIONS PERMISSIBLE UNDER STATUTES.....	16
2.28 TAXES.....	16
2.29 FRAUD AND CORRUPTION .....	16
2.30 TERMS AND CONDITIONS OF THE TENDER .....	16
<b>3 PAYMENT TERMS &amp; WARRANTY .....</b>	
3.1 PAYMENT TERMS .....	17
3.2 PAYMENT PROCEDURE .....	18
3.3 WARRANTY TERMS .....	20
<b>4 SERVICE LEVEL AGREEMENT (SLA) .....</b>	
4.1 IMPLEMENTATION STAGE SLA.....	21
4.2 OPERATIONS STAGE SLAs .....	22
4.2.1 <i>Network related Operational Service levels</i> .....	
4.2.2 <i>Helpdesk SLA</i> .....	
4.3 SERVICE LEVELS MONITORING .....	24

4.4	REPORTING PROCEDURES.....	24
4.5	EXCLUSIONS.....	24
<b>5</b>	<b>EVALUATION FRAMEWORK .....</b>	
5.1	THREE STAGE BID SYSTEM .....	26
5.2	PRE-QUALIFICATION CRITERIA.....	27
5.3	QUALIFYING CRITERIA FOR TECHNICAL BID .....	31
5.4	TECHNICAL BID EVALUATION .....	32
5.5	COMMERCIAL BID EVALUATION .....	33
5.6	REJECTION CRITERIA .....	34
5.6.1	<i>General rejection criteria.....</i>	
5.6.2	<i>Pre-Qualification Rejection Criteria.....</i>	
5.6.3	<i>Technical Rejection Criteria .....</i>	
5.6.4	<i>Commercial Rejection Criteria.....</i>	
<b>6</b>	<b>PREQUALIFICATION BID FORMATS .....</b>	
6.1	PQ FORMAT 1 - PREQUALIFICATION BID CHECKLIST .....	36
6.2	PQ FORMAT 2 - PREQUALIFICATION BID COVER LETTER .....	37
6.3	PQ FORMAT 3 - BIDDER PROFILE.....	38
6.4	PQ FORMAT 4- PRE-QUALIFICATION CRITERIA COMPLIANCE.....	39
6.5	PQ FORMAT 5 - FORMAT FOR POWER ATTORNEY TO AUTHORIZE SIGNATORY .....	42
6.6	PQ FORMAT 6 - FORMAT FOR POWER OF ATTORNEY FOR LEAD BIDDER .....	43
6.7	PQ FORMAT 7 - CERTIFICATE OF NON-BLACKLISTING.....	44
6.8	PQ FORMAT 8 - SELF-DECLARATION.....	45
6.9	PQ FORMAT 9 - NON-DISCLOSURE AGREEMENT .....	46
<b>7</b>	<b>TECHNICAL BID FORMATS.....</b>	
7.1	TECH FORMAT 1-TECHNICAL BID CHECKLIST .....	48
7.2	TECH FORMAT 2- TECHNICAL BID COVER LETTER.....	49
7.3	TECH FORMAT 3- PROJECT CITATIONS SUMMARY & DETAILS FOR PACKAGE A .....	51
7.4	TECH FORMAT 4- APPROACH & METHODOLOGY.....	52
7.5	TECH FORMAT 5- WORK PLAN AND STAFFING PLAN .....	54
7.5.1	<i>Personnel required for project execution.....</i>	
7.5.2	<i>Work Schedule and planning .....</i>	
7.5.3	<i>Staffing Schedule.....</i>	
7.6	TECH FORMAT 6- CV .....	57
7.7	TECH FORMAT 7- SUMMARY & DETAILED SHEETS OF COMPLIANCE TO THE BENCHMARKS/MINIMUM SPECIFICATIONS .....	60
7.8	TECH FORMAT 8- MANUFACTURER AUTHORIZATION FORM FROM OEMS.....	61
7.9	TECH FORMAT 9- DETAILS OF CABLE MANUFACTURER/SUPPLIER .....	62
7.10	TECH FORMAT 10- STATEMENT OF DEVIATION .....	63
7.10.1	<i>Deviation to Technical Specification.....</i>	
7.10.2	<i>Deviation to Commercial Conditions .....</i>	
<b>8</b>	<b>COMMERCIAL BID FORMATS.....</b>	
8.1	GENERAL INSTRUCTIONS.....	66
8.2	COMMERCIAL BID LETTER .....	67
8.3	BoQ FOR PACKAGE A <i>*(TO BE FILLED IN THE EXCEL PROVIDED)</i> .....	69
8.4	BoQ FOR PACKAGE B <i>*(TO BE FILLED IN THE EXCEL PROVIDED)</i> .....	79
8.5	OPTIONAL ITEMS.....	80
8.6	O&M FOR BOTH PACKAGES <i>*(TO BE FILLED IN THE EXCEL PROVIDED)</i> .....	81
8.7	PRICE BID FORMAT.....	83
<b>9</b>	<b>FORMAT FOR PERFORMANCE BANK GUARANTEE .....</b>	
<b>10</b>	<b>INTEGRITY PACT .....</b>	

**11 DRAFT MASTER SERVICE AGREEMENT (MSA) .....**

## Definitions

#	Term	Definition
1.	<b>Agreement/ Contract</b>	the Agreement entered between Authority and the Systems Integrator including all attachments, schedules, annexure thereto and all documents incorporated by reference therein and all amendments, corrigendum /corrigenda, changes thereto
2.	<b>Client/ Authority</b>	Kerala Fibre Optic Ltd. acting for and on behalf of the Government of Kerala and represented by the Managing Director, Kerala Fibre Optic Ltd.
3.	<b>Bidder</b>	The use of the term “Bidder” in the Tender means the Single or the Lead Member of the consortium of firms not exceeding three.
4.	<b>Bid/Proposal</b>	Offer by the Bidder to fulfil the requirement of the Client/Authority under the RfP/Contract for an agreed price. It shall be a comprehensive technical and commercial response to the Tender
5.	<b>Breach</b>	A breach by Bidder of any of its obligations under this Agreement
6.	<b>Confidential Information</b>	All information including Authority’s data (whether in written, oral, electronic or other format) which relates to the technical, financial and business affairs, dealers, suppliers, products, developments, operations, processes, data, trade secrets, design rights, know-how, plans, budgets and personnel of each department and its affiliates which is disclosed to or otherwise learned by the other Party in the course of or in connection with this Agreement (including without limitation such information received during negotiations, location visits and meetings in connection with this Agreement);
7.	<b>Consortium</b>	The consortium consist of multiple members (not more than 3 parties including the Lead Bidder) entering into a Consortium Agreement for a common objective of satisfying the Authority’s requirements & represented by Lead Member of the consortium
8.	<b>Control</b>	In relation to any business entity, the power of a person to secure a) by means of the holding of shares or the possession of voting power in or in relation to that or any other business entity, or b) by virtue of any powers conferred by the articles of association or other document regulating that or any other business entity, that the affairs of the first mentioned business entity are conducted in accordance with that person’s wishes and in relation to a partnership, means the right to a share of more than one half of the assets, or of more than one half of the income, of the partnership;
9.	<b>Deliverables</b>	Products, infrastructure and services agreed to be delivered by the Bidder in pursuance of the agreement as defined more elaborately in the RfP Implementation and the Maintenance phases and includes all documents related to the user manual, technical manual, design, process and operating manuals, service mechanisms, policies and guidelines (such as security related, data migration related), inter alia payment and/or process related etc., source code and all its modifications;
10.	<b>Go-Live</b>	The date of commencement of Operations and Maintenance phase after the successful completion of each milestone(acceptance of the milestone by the Authority)

#	Term	Definition
11.	<b>Intellectual Property Rights</b>	All rights in written designs and copyrights, moral rights, rights in databases and Bespoke Software / Pre-existing work including its up-gradation systems and compilation rights (whether or not any of these are registered and including application for registration);
12.	<b>Month/ Week</b>	The Month shall mean calendar month & Week shall mean calendar week
13.	<b>Parties</b>	Authority and Bidder for the purposes of this Agreement and “ <b>Party</b> ” shall be interpreted accordingly;
14.	<b>Performance Security</b>	Unconditional guarantee provided by the Bidder from a Scheduled Commercial Bank/Nationalized Bank in favour of the Authority for 10% of the total CAPEX value (both packages incl.)
15.	<b>Project</b>	Project shall mean implementation of the two packages:- Package A - Kerala Fibre Optic Network Package B - Reliable Communication and Data Acquisition Network
16.	<b>Project Implementation</b>	Project Implementation as per the testing standards and acceptance criteria prescribed by Authority or its nominated agencies;
17.	<b>Request for Proposal/ Tender Document</b>	Written solicitation that conveys to the Bidder, requirements for products/ services that the Authority intends to buy and implement
18.	<b>Service Level</b>	The level of service and other performance criteria which will apply to the Services delivered by the Bidder;
19.	<b>SLA</b>	Performance and Maintenance SLA executed as part of this Master Service Agreement
20.	<b>Software</b>	Software designed, developed / customized, tested and deployed by the Bidder for the purposes of the Project and includes the source code (in case of Bespoke development) along with associated documentation, which is the work product of the development efforts involved in the Project and the improvements and enhancements effected during the term of the Project, but does not include the third party software products (including the COTS products used for the product), proprietary software components and tools deployed by the Bidder;
21.	<b>Network System</b>	Network System shall mean implementation of the two packages:- Package A - Kerala Fibre Optic Network Package B - Reliable Communication and Data Acquisition Network
22.	<b>Successful Bidder</b>	The bidder who is qualified & successful in the bidding process and is given the award of Contract and will be referred to as System Integrator(SI)

Table 1: Definitions



# 1 Bidding Data Sheet

Notice Inviting Tender		
1.	<b>Name of the Tender Inviting Authority</b>	Kerala State Information Technology Infrastructure Ltd. (KSITIL) on behalf of Kerala Fibre Optic Network Ltd.
2.	<b>Officer Tender Inviting Authority</b>	Managing Director, KSITIL
3.	<b>Name of the Project</b>	Project shall mean implementation of the two packages:- Package A - Kerala Fibre Optic Network Package B - Reliable Communication and Data Acquisition Network
4.	<b>Tender Reference Number</b>	KSITIL/MD/KFON/18/1852
5.	<b>Tender Type</b>	Open
6.	<b>Tender Category</b>	Supply and Services
7.	<b>Publication of Tender Document</b>	As per e-tender website
8.	<b>Contact Person</b>	Company Secretary, KSITIL
9.	<b>Address</b>	Kerala State Information Technology Infrastructure Ltd., TC No.: 14/196/2, 3rd Floor, Chandrasekharan Nair Stadium, Palayam, Trivandrum - 695033
10.	<b>Contact No.</b>	0471-2304006
11.	<b>E-Mail ID, for any clarifications</b>	ksitil@ksitil.org
12.	<b>Time &amp; last date to submit clarifications</b>	As per e-tender website
13.	<b>Pre-bid Meeting</b>	As per e-tender website
14.	<b>Pre-Bid Meeting Venue</b>	As per e-tender website
15.	<b>Procedure for Bid Submission</b>	Through e-tendering platform of Government of Kerala
16.	<b>Last Date of Submission of Bids</b>	As per e-tender website
17.	<b>Opening of Prequalification Bids</b>	As per e-tender website
18.	<b>Bid System</b>	Three stage bid system 1. Pre-qualification Bid 2. Technical Bid 3. Financial / Commercial Bid
19.	<b>Bid Processing Fee (Non -Refundable)</b>	Rs. 10 lakhs only
20.	<b>Bid Security/EMD (Refundable)</b>	Rs. 25 lakhs only (by <b>online NEFT/SBI Internet banking</b> )
21.	<b>Validity of the Bid</b>	3 months from the date of opening of price bid
22.	<b>Contract period</b>	24 months + 7 years
23.	<b>Performance Security (PS)</b>	10% of the total CAPEX value (both packages incl.) In the form of a Bank Guarantee issued by any Nationalized / Scheduled Commercial Bank in favour of

		"Managing Director, Kerala Fibre Optic Network Ltd.", payable at Thiruvananthapuram.  Performance Security must be furnished within 15 days from the date of receipt of notification of award (Letter Of Intent)
<b>24.</b>	<b>Performance Security validity period</b>	12 months beyond expiry of contract period
<b>25.</b>	<b>Period of Signing the contract</b>	Within 21 days from the date of receipt of notification of award (Letter Of Intent)
<b>26.</b>	<b>Terms &amp; Conditions</b>	As per the Tender document

*Table 2: Bidding Data Sheet*

**Note:**

- The Bidding process shall be conducted online (e-tendering). Please visit <https://etenders.kerala.gov.in/> for further details regarding the e-tendering process.
- All the notification/details and terms and conditions regarding this tender notice hereafter will be published on line on web site <https://etenders.kerala.gov.in/>
- All the clarifications / corrigendum to the queries will be published on the above said websites.

## 2 Instruction to Bidders

### 2.1 Procurement under Kerala Fibre Optic Network

Managing Director, Kerala State IT infrastructure Ltd. invites bids on behalf of Managing Director, Kerala Fibre Optic Network Ltd. from eligible Bidders for the selection of an agency for the execution two packages.

- Package A – Design, Implementation and Maintenance **Kerala Fibre Optic Network**
- Package B – Providing **Reliable Communication and Data Acquisition Network** and above 110kV Voltage level in Kerala

Participating entities shall agree to adhere to the Terms & Conditions, Scope & Services and Specifications of the components procured mentioned under both the packages.

This tender has two volumes:-

- Volume I: Bidding Instructions and Terms & Conditions
- Volume II: Scope of Services & Specifications for Kerala Fibre Optic Network and Reliable Communication and Data Acquisition Network

All the terms and conditions are to be read jointly as mentioned in the e-procurement market website (<https://etenders.kerala.gov.in/>) and in this document.

### 2.2 Due Diligence

Bidder is expected to examine all instructions, forms, terms and specifications in the Tender Document. The Bid should be precise, complete and in the prescribed format as per the requirement of the Tender Document. Failure to furnish all information required by the Tender Document or submission of a bid not responsive to the Tender Document in every respect will be at the Bidder's risk and may result in rejection of the bid.

### 2.3 Cost of Bidding

Bidder shall bear all costs associated with the preparation and submission of its Bid and the Authority shall in no event be held responsible or liable for these costs, regardless of the conduct or outcome of the bidding process.

### 2.4 Language of the Bid

The bids prepared by the Bidder and all subsequent correspondence and documents relating to the Bids exchanged by the Bidder and the Authority shall be written in English language. Any printed literature furnished by the Bidder, written in another language, shall be accompanied by an accurate English translation, in which case, for purposes of interpretation of the Bid, the English translation shall govern.

### 2.5 Pre-Bid Meeting & Clarifications

The Authority, will host a Pre-Bid meeting for queries (if any) by the prospective bidders. The meeting will be held on the date and venue as specified in Bidding Data Sheet. **The representatives of the bidders (limited to three) attend the pre-bid meeting at their own cost.** The purpose of the pre-bid meeting is to provide a forum to the bidders to clarify their doubts / seek clarification or additional information, necessary for them to submit their Bid.

The prospective bidder requiring any clarification on the bidding document may notify the Authority in writing or by e-mail in a non-editable format. The official mentioned in the Bidding Data Sheet may be contacted for this purpose.

The queries should necessarily be submitted in the following format:

#	RfP Volume no.	Page no.	Section No.	Content/Clause of the requiring clarification	Clarification Sought

Queries submitted post the deadline mentioned in the e-tender website or which do not adhere to the above mentioned format may not be responded to.

## **2.6 Amendment of the Tender Document**

At any time prior to the submission of Bids, Authority for any reason whatsoever, may, modify any element of the Tender Document by issuing a corrigendum. All Amendment(s)/Corrigendum(s) shall be published on the **etenders.kerala.gov.in** Authority shall not be responsible for bidder's negligence in checking the website regularly for any updates on this tender. For the sake of interpretation, the content of any corrigenda issued by the Authority shall be read as part of the original Tender Document. In each instance in which provisions of the Corrigenda contradict or are inconsistent/ inapplicable with the provisions of the Tender Document, the provisions of the Corrigenda shall prevail and govern, and the contradicted or inconsistent/inapplicable provisions of the Tender shall be deemed amended accordingly.

The Authority may in its sole discretion consider extension of deadlines for submission of the Bids, in order to allow prospective bidders reasonable time in which to take the amendment into account while preparing their Bids. All the communications with regards to the clarifications / corrigendum shall be made to the bidders who have purchased the Tender Documents.

## **2.7 Compliance/Completeness of the Bid**

Submission of a Bid by the Bidder shall be through e-Tendering system of Government of Kerala and should be done after careful study and examination of the Tender Documents, with full understanding of its implications. Bidder is expected to understand the requirements to allow them to propose the best fit solution. Bidders' attention is also drawn to the Compliance Sheet as provided in this Volume of the Tender Document.

Proposal is to be submitted as per the enclosed format only along with certificates, brochures and other documents as asked for in the Tender Document. Failure to comply with the requirements of this paragraph may render the Bid non-compliant and the Bid may be rejected. Bidders must:

- Include all documentation specified in this Tender Document;
- All pages of the Bid must be numbered and duly signed by the Authorized Signatory;
- Strictly follow the format prescribed and respond to each element in the order as set out in this Tender

## **2.8 Documents comprising the Bid**

Bidders shall upload response to this Tender as per the requirements below.

### **2.8.1 Pre-Qualification Bid**

1. PQ Formats 1 -9

### **2.8.2 Technical Bid**

1. Tech Formats 1 -10
2. Unpriced BoQ

### 2.8.3 Commercial Bid

1. Commercial Bid Covering Letter
2. Duly filled BoQ
3. Optional items BoQ (as PDF)

**Note:-**

- The bidder is requested to view and ensure that all the data entered is visible in the final PDF file before uploading. If more space is required, attach scanned copies of information in PDF format and upload as a single PDF document along with all other scanned certificates/documents mentioned elsewhere in the bid documents.
- Bidders shall upload legible scanned copies of certificates/documents. Documents which are illegible or incomplete will not be considered.
- All PDFs shall be given appropriate file names
- There is no provision for correction of bids once submitted online. However, revised bids can be submitted by the Bidder, in case of corrections, till the last date & time of bid submission and the most recent/latest bid submitted before the stipulated date & time of bid submission shall only be considered by etenders.kerala.gov.in website for further processing.

### 2.9 Submission of hard copy of Pre-qualification and Technical Bid Documents

Bidder shall submit one hard copy each for the Bid Documents - Pre-qualification and Technical Bid Documents at the office of the Authority within the prescribed Bid submission date mentioned in the e-tender website. **However, the financial Bid shall be submitted through Bid-tender only** Bid Documents shall be submitted in separate sealed covers with the following details:-

1. Details to be printed on the cover for Pre-qualification Document:-

**Selection of an Agency for Implementation of Kerala Fibre Optic Network & Reliable Co  
Data Acquisition Network**

**Pre-qualification Bid Document**

Date of Submission: DD MM YYYY

Name of the Bidding Entity: xxx

Address of the Bidding Entity: xxx

Contact name and number of the Bidding Entity: xxx

2. Details to be printed on the cover for Technical Document :-

**Selection of an Agency for Implementation of Kerala Fibre Optic Network & Reliable Co  
Data Acquisition Network**

**Technical Bid Document**

Date of Submission: DD MM YYYY

Name of the Bidding Entity: xxx

Address of the Bidding Entity: xxx

Contact name and number of the Bidding Entity: xxx

## **2.10 Hand written documents, Erasures or Alterations**

The offers containing erasures or alterations will not be considered. There should be no hand-written material, corrections or alterations in the offer. Filling up of the information using terms such as “OK”, “noted”, “as given in brochure/manual” is not acceptable and may lead to the dis-qualification of the Bid.

## **2.11 Bid Security/Earnest Money Deposit (EMD)**

Bidders should submit the Bid Security as mentioned in the Bidding Data Sheet. The Bid Security of all unsuccessful bidders will be refunded through online transfer, on receipt of letter of acceptance from Successful Bidder along with security deposit. The Bid Security amount is interest free and will be refundable to the unsuccessful bidders without any accrued interest on it. Bid Security shall be returned to the Successful Bidder upon signing of contract and submission of Performance Security.

The Bid submitted without Bid Security, mentioned above, will be summarily rejected. The Bid Security may be forfeited:

- If a Bidder withdraws its bid during the period of bid validity
- If the Successful Bidder fails to sign the contract or submit Performance Security within the stipulated period.

## **2.12 Variation of Quantity**

The Authority reserves the right to increase or decrease quantity while placing the actual order up to +/- 25% on each line item. However, the payment shall be made against actual. The Successful Bidder is bound to deliver the requested quantity at the work order price.

## **2.13 Bid Prices**

The Bidder shall indicate in the proforma prescribed, the unit rates and total bid prices for the equipment / services, it proposes to provide under the Agreement. Prices should be shown separately for each item as detailed in this Tender Document.

The Bidder shall prepare the Bid based on details provided in the Tender Documents. It must be clearly understood that the Scope of Work is intended to give the Bidder an idea about the order and magnitude of the work and is not in any way exhaustive and guaranteed by the Bidder. The Bidder shall carry out all the tasks in accordance with the requirement of the tender documents and with due diligence. It shall be the responsibility of the Bidder to fully meet all the requirements of the Tender Documents and to meet objectives of the Project.

## **2.14 Firm Prices**

Prices quoted in the bid must be firm and final and shall not be subject to any modifications, on any account whatsoever. **The bid prices shall be indicated in Indian Rupees (INR) only.** The Bidder shall offer materials which fully satisfy the technical specification given in the bid. It shall offer full quantity of item tendered. It should not quote part quantity.

The Commercial Bid should clearly indicate the price quoted without any ambiguity / qualifications whatsoever and should include all applicable taxes, duties, fees, levies, and other charges as may be applicable in relation to the activities proposed to be carried out. It is mandatory that such charges wherever applicable / payable should be indicated separately. Should there be a change in applicable taxes, the actual taxes on the date of billing would prevail.

**Prices in any form or by any reason before opening the Commercial Bid should not be re the offer shall be liable for rejection.**

## **2.15 Inspection of Site and sufficiency of Tender**

Bidder is expected to work out their own rates based on the detailed description of scope of work items, the specifications, SLA conditions, etc. and should judiciously arrive at the commercials. The Bidder shall be deemed to have satisfied itself before Bid submission as to correctness and sufficiency of its Tender. The rates and prices quoted shall cover all its obligations under the contract necessary for proper completion and maintenance of the Works/Services.

If necessary, before submitting its Bid the Bidder should inspect and examine various sites and its surroundings and shall satisfy itself about form and nature of the sites means of access to the Sites, and in general, obtain all necessary information which may influence or affect Project implementation and operationalization. No extra charges consequent on any misunderstanding or otherwise shall be allowed.

## **2.16 Conditional bids by the bidders**

The Bidder should abide by all terms and conditions specified in the Tender Document. Conditional offers shall be liable for dis-qualification.

## **2.17 Late Tender Bids**

Any Bid received by the Authority after the deadline for submission of Bid prescribed by the Authority, will be summarily rejected.

## **2.18 Bid Validity Period**

Bids shall be valid for a period as mentioned in the Bidding Data Sheet. A Bid valid for shorter period may be considered as non-responsive. In exceptional circumstances, at its discretion, Authority may solicit the Bidder's consent for an extension of the validity period. The request and the responses thereto shall be made in writing or email.

## **2.19 Opening of Bids**

Bids received within the prescribed closing date and time will be opened at the prescribed date and time of Bid opening. In case it is not possible to open the tender on the specified time and date due to any valid reason, the revised time and date will be published on the [etenders.kerala.gov.in](http://etenders.kerala.gov.in) website.

## **2.20 Clarification of Bids**

To assist in the scrutiny, evaluation and comparison of bids, Authority may, at its discretion, ask some or all Bidders for clarifications with regards to their Bid. The request for such clarifications and the response will necessarily be in writing (by letter/email). Failure of a Bidder to submit additional information or clarification as sought by Authority within the prescribed period will be considered as a non-compliance and the Bid may get evaluated based on the limited information furnished along with the Bids.

## **2.21 Right to accept any Bid and reject any or all Bids**

Authority reserves the right to accept or reject any Bid, and to annul the tendering process and reject all Bids at any time prior to award of contract, without thereby incurring any liability to the affected Bidder(s) or any obligation to inform the affected Bidder(s) of the grounds for such action.

## **2.22 Notification of Award**

Authority will notify the Successful Bidder via letter/email of its intent of accepting the Bid. Within seven (7) days of receipt of the Letter of Intent (LOI) by the Authority, the Successful Bidder shall be required to sign the LOI and return the same to the address specified in the Bidding Data Sheet as a token of acceptance of the LOI.

## **2.23 Performance Security (PS)**

As a condition precedent to execution of the Agreement, the Successful Bidder shall ensure submission of the requisite unconditional irrevocable Bank Guarantee, in the prescribed format within 15 (fifteen) days of receipt of the LOI as a Performance Security for the services to be performed under the resultant Agreement. The Bank Guarantee amount and its validity shall be equivalent to that mentioned in the Bidding Data Sheet. Performance Security may be subject forfeiture as per the clauses mentioned in the Tender Document

Bid Security of the Successful Bidder shall be returned on submission of PS by Successful Bidder after successful execution of the Agreement.

The Performance Security may be liquidated by the Authority as penalty / liquidated damages resulting from the System Integrator's (SI) failure to complete its obligations under the resultant Agreement. The Performance Security shall be returned by Authority to the Bidder within thirty (30) days of the term/expiration of the resultant Agreement after applicable deductions as per the Agreement, if any.

## **2.24 Signing of Contract**

Subsequent to Authority notification to the Successful Bidder by way of a LOI, acceptance of the LOI and submission of the Performance Security, the Successful Bidder shall execute the Agreement with the Authority. Failure of the Successful Bidder to furnish the Performance Security or execute the agreement within the prescribed time shall cause the Bid Security of the Successful Bidder to be liquidated. In such event, the Authority may choose to negotiate with the next eligible Bidder. The Successful Bidder will be liable to indemnify the Authority for any additional cost or expense, incurred on account of failure of the Successful Bidder to execute the Agreement.

Notwithstanding anything to the contrary mentioned above, the Authority at its sole discretion shall have the right to extend the timelines for execution of Agreement on the request of the Successful Bidder, provided the same is bona fide.

The draft Agreement between the Authority and the Successful Bidder has been provided in this Volume of the Tender Document.

## **2.25 Integrity Pact**

An "Integrity Pact" shall be signed between the Authority and the SI. This is a binding agreement between Authority and SI. Under this Pact, the SI agrees with the Authority to carry out the assignment in a specified manner. The format of Pre-Contract Integrity Pact will be as per format given in the annexure. In case of a consortium, all members have to sign the pact.

The following set of sanctions shall be enforced for any violation by a Bidder of its commitments or undertakings under the Integrity Pact:

- Denial or loss of contracts;
- Forfeiture of the EMD and PBG;
- Liability for damages to the SI; and
- Debarment of the violator by Government of Kerala for an appropriate period of time.

The Bidders are also advised to have a company code of conduct (clearly rejecting the use of bribes and other unethical behaviour compliance program for the implementation of the code of conduct throughout the company.

## **2.26 IT Act 2008**

Besides the terms and conditions stated in this document, the Contract shall also be governed by the overall acts and guidelines as mentioned in IT Act 2008 (Amendment)



## **2.27 Concessions permissible under statutes**

Bidder, while quoting against this tender, must take cognizance of all concessions permissible, if any, under the statutes and ensure the same is passed on to the Authority, failing which it will have to bear extra cost. In case Bidder does not avail concessional rates of any levies, the Authority will not take responsibility towards this. However, the Authority may provide necessary assistance, wherever possible, in this regard.

## **2.28 Taxes**

The Bidders shall fully familiarize themselves about the applicable domestic taxes on amounts payable by the Authority under the Agreement. All such taxes must be included by Bidders in the financial proposal. (Bidder needs to find out applicable taxes for the components being proposed.)

## **2.29 Fraud and corruption**

Authority requires that Bidder must observe the highest standards of ethics during the entire process of tendering and during execution of the Agreement. In pursuance of this policy, the Authority defines, for the purpose of this provision, the terms set forth as follows:

- a. "Corrupt practice" means the offering, giving, receiving or soliciting of anything of value to influence the action of the Authority in Agreement executions.
- b. "Fraudulent practice" means a misrepresentation of facts, in order to influence a procurement process or the execution of a contract, to Agreement, and includes collusive practice among bidders (prior to or after Bid submission) designed to establish Bid prices at artificially high or non-competitive levels and to deprive the Authority of the benefits of free and open competition.
- c. "Unfair trade practices" means supply of services different from what is ordered on, or change in the Scope of Work which is given by the Authority in Volume II of the Tender.
- d. "Coercive Practices" means harming or threatening to harm, directly or indirectly, persons or their property to influence their participation in the execution of contract.

Authority shall reject the Bid proposal for award of contract, if it determines that the Bidder recommended for award, has been found to have been engaged in corrupt, fraudulent or unfair trade practices. Once the contract is signed and if it is noticed that the SI has indulged into the Corrupt / Fraudulent / Unfair / Coercive practices, it will be a sufficient ground for the Authority for termination of the Agreement and initiate black-listing of the Bidder.

## **2.30 Terms and conditions of the Tender**

Bidder is required to refer to the draft Master Service Agreement, provided in this Volume of the Tender Document for all the terms and conditions (including project timelines) to be adhered by the Successful Bidder during Project implementation and Post implementation period. Please note that one needs to read the Master Service Agreement as a whole document; and the Annexures mentioned there-in may not correspond to the Tender Annexures. Please refer to the Interpretation Section of the Agreement for reference of the Annexures.

### 3 Payment Terms & Warranty

#### 3.1 Payment Terms

Milestone/ Activity	Implementation Period				Payment against live
	Fiber & Accessories		Network IT and Non- IT equipment		
	Payment against Supply % of the total cost incurred for supply, installation, testing & commissioning of entire fiber & accessories for the respective milestone	Payment against Installation, Testing & Commissioning % of the total cost incurred for supply, installation, testing & commissioning of entire fiber & accessories for the respective milestone	Payment against Supply paid as a % of the total cost incurred for supply, installation, testing & commissioning of entire IT/Non-IT components for the respective milestone	Payment against Installation, Testing & Commissioning and Integration with NOC paid as a % of the total cost incurred for supply, installation, testing & commissioning of entire IT/Non-IT components for the respective milestone	
Core Ring + associated institutions	30%	30%	30%	30%	30% of Total Capex against the two milestones
NOC			30%	30%	
Aggregation Ring + associated institutions	30%	30%	30%	30%	30% of Capex against the milestone
Pre-Aggregation Ring + associated institutions	30%	30%	30%	30%	30% of Capex against the milestone
Spur Connectivity + associated institutions	30%	30%	30%	30%	30% of Capex against the milestone
Remaining fiber laying in PSDF	30%	30%			30% of Capex against the milestone

- 1) Commissioning means completion in all respect including commissioning of all Fibre/accessories/IT/Non-IT equipment, testing by SI and certification by PMA and final approval by Authority.
- 2) Integration means integration and testing of all network components in place – Fibre, Electronics, PoPs, end institutions and NOC with all hardware, software and non-IT Infrastructure commissioned
- 3) **Authority wishes to incentivize the SI for early completion of the Project (Package B). The incentives for early completion are as given below:-**

Sl. No.	Timeline from signing of contract	Incentives % of CAPEX
1.	12 months	5%
2.	13 months	4.9%
3.	14 months	4.6%
4.	15 months	4.2%
5.	16 months	3.6%
6.	17 months	2.9%
7.	18 months	2.0%
8.	19 months	1.9%
9.	20 months	1.7%
10.	21 months	1.5%
11.	22 months	1.1%
12.	23 months	0.5%
13.	24 months	0%

Table 3: Early Completion Incentive

- 4) All payments will be subject to deductions of SLA accrual applicable at any payment milestone.
- 5) Quarterly payment to SI for Operations and Maintenance Phase will be made for all locations which are commissioned before the start of the respective quarter.
- 6) Penalty clauses shall be applicable during implementation & O&M periods for breach of SLA made by SI.
- 7) Bidder may propose a suitable project plan to achieve the milestones as per the timelines mentioned. All phases/milestones/activities may be carried out sequentially or in parallel. However, **the project should be completed within the overall timeline of 24 months.**
- 8) The suppliers at their cost shall arrange for storage, loading and unloading of materials at site.
- 9) In case the SI, after having made partial supplies, fail to fulfill the contract in full or partial, such risk and loss if any, caused to the Authority thereby shall be recovered from the defaulting SI by forfeiting the Performance Bank Guarantee and the balance alone shall be refunded.
- 10) If the materials which are rejected by the Authority, on inspection/testing, are not lifted from the site within 15 days of receipt of the intimation of rejection by the Authority, the SI shall be liable to pay ground rent @ 0.1% of the above value of rejected materials for every day of delay.
- 11) The bidders should be prepared to accept order on condition that in the event of their defaults to supply and installation as ordered/failure to supply within the period stipulated in the order, the security deposit will be forfeited.
- 12) All incidental expenses incurred by the Authority for making payment outside the District in which the claims arises shall be borne by the contractors.
- 13) Any sum of money due and payable to the Bidder (including security deposit returnable to him) under this contract may be appropriated by the Authority and set off against any claim of the Authority for the payment of a sum of money arising out of or under any other contract made by the bidder with the Authority

### 3. Payment Procedure

- A milestone shall be considered complete only on
  - completion of the activities envisaged under that milestone
  - Verification of all activities under that milestone by PMA and acceptance by Authority
  - Submission of all required reports like site survey, design document, test/delivery reports, etc.
- **Within two weeks of contract signing the SI shall submit an inception report with a plan**

- For each milestone, SI shall submit the BoQ based on the verified and approved site survey reports.
- Payments against supply shall be processed only upon verification of the quantity delivered by the PMA against the approved BoQ and submission of all the test reports – type tests, factory acceptance test, dispatch clearances, delivery reports, etc.
- On Go-Live of each milestone SI shall submit a network commissioning report for that particular milestone for payment processing
- Upon completion of a milestone, SI shall submit the invoice and all relevant documents (timely and complete) for scrutiny by PMU. PMU shall provide its payment recommendation within 14 working days.
- All efforts shall be made by the Authority to release the payment within 30 working days.
- All Payments shall be made via NEFT/RTGS in Indian Rupees Only
- SI shall share all information required to receive the payments electronically
- Payments shall be subject to deductions of any amount for which the SI is liable under the RFP conditions. Further, all payments shall be made subject to deduction of TDS (Tax Deduction at Source) as per the current Income-Tax Act.
- Bank charges, if any, incurred in connection with effecting payment to the SI will be to the SI's account.
- Also in case the documentary proof for remittance of taxes & duties are not made available, the following shall be produced before the Authority for effecting the payment of the same.
  - Copy of e-return filed, for Proof of payment of tax.
  - Certificate giving invoice wise details of taxes & duties from the Chartered Accountant as a documentary proof of payment of taxes.
  - An undertaking from the supplier stating that “ if any dispute on payment of taxes and duties from concerned tax authorities occurs in future, the firm shall indemnify the Authority from such liabilities and the supplier will be made liable for the additions, loss or cost on account of such discrepancies/dispute.”
- Final payment will be made on production of an undertaking by the SI that all taxes and duties payable to the Central/ State Government Department/ Agencies due to the Supply/ Contract have been paid by him and if any claim is received in future from any Central/ State Government Department/ Agencies under existing laws regarding this supply /contract, the Supplier/ Contractor shall be liable to pay the same.
- If pursuant to or under any law, notification or order any royalty, cess, tax or the like becomes payable by Authority to the State Government or local authorities as a result of any material used by the SI in the works, then in such a case, Authority will have the right to recover the amount paid in the circumstances as aforesaid from dues of the SI.
- Conditions for reimbursement of levy/ taxes if levied after receipt of tenders
  - All tendered rates shall be inclusive of all taxes and levies payable under respective statutes.
  - The SI shall keep necessary books of accounts and other documents for the purpose of this condition as may be necessary and shall allow inspection of the same by Authority or its authorized representative and shall also furnish such other information/ document as Authority may require from time to time.
  - Apprentices Act provisions to be complied with the SI shall comply with the provisions of the Apprentices Act, 1961 and the rules and orders issued there under from time to time. If he fails to do so, its failure will be a breach of the contract and Authority may, in its discretion, cancel the contract. The SI shall also be liable for any pecuniary liability arising on account of any violation by him of the provisions of the said Act.

### 3.3 Warranty Terms

1. A comprehensive on-site warranty and Operations & Maintenance on all goods supplied under this contract shall be provided by the respective Original Equipment Manufacturer (OEM) through SI till the end of the Contract.
2. Technical Support shall be provided by the respective OEM for till the end of the contract period.
3. The SI shall warrant that the goods supplied under the Contract are new, non-refurbished, unused and recently manufactured; shall not be nearing End of Sale/End of Support and shall be supported by the SI and respective OEM along with service and spares support to ensure its efficient and effective operation for the entire duration of the contract.
4. The SI shall warrant that the goods supplied under this contract shall be of reasonably acceptable grade and quality and consisted with the established and generally accepted standards for materials of this type. The goods shall be in full conformity with the specifications and shall operate properly and safely. All recent design improvements in goods, unless provided otherwise in the Contract, shall also be made available.
5. The SI shall further warrant that the Goods supplied under this Contract shall be free from all encumbrances and defects/faults arising from design, material, manufacture or workmanship (except insofar as the design or material is required by the Specifications)
6. The Authority shall promptly notify the SI in writing of any claims arising under this warranty.
7. Upon receipt of such notice, the SI shall, with all reasonable speed, repair or replace the defective Goods or parts thereof, without prejudice to any other rights which the Authority may have against the SI under the Contract.
8. If the SI, having been notified, fails to remedy the defect(s) within a reasonable period and remove the defective parts from site within fifteen (15) days, the Authority may proceed to take such remedial action as may be necessary, at the SI's risk & expense and without prejudice to any other rights which the Authority may have against the SI under the Contract.
9. Bidder will quote all the capex items with specified warranty period as part of the capex cost. The support cost for HW/SW in non-warranty period will be quoted as Annual Maintenance Cost (AMC) for the particular period in the contract period. The AMC/Support cost will be applicable only upon Go-Live after completion of warranty for any particular item.
- 10. Warranty for active equipment will be for 5 years from the date of Go-Live of that CAPEX of all equipment shall be inclusive of the 5 years warranty**
- 11. SI shall submit performance warranty of 25 years for OFC/OPGW obtained from OEM**
12. All the materials that are ordered have to be fully insured from the time of despatch from the manufacturer's works to the destination station and for one-month storage thereafter at the cost of the supplier. Proof of insurance shall be furnished.
13. During the warranty period, the SI shall guarantee that there shall be minimum outage of the supplied system. During this period, the SI shall replace or repair all defective parts and shall have prime responsibility for maintaining an operational system. During the warranty period, the spare parts, test equipment and tools and tackles shall be provided by the SI without any additional cost to the Authority. In case if any mandatory spare parts supplied to Authority in this contract has been used during warranty period, the same shall be replenished by the SI without any additional cost to Authority.
14. The SI shall provide all required consumable and non-consumable supplies necessary to support all installation and test activities till the completion of the project. If there are any problems in the SAT and additional consumables are required, the same shall also be supplied by the SI in free of cost.

## 4 Service Level Agreement (SLA)

### 4.1 Implementation stage SLA

SLA Parameter	Delay in implementat milestone	Penalty
Delays in milestones attributable to SI	<= 1 week	No Penalty
	>1 week to < 4 Weeks	0.5% of the milestone payment
	>= 4 to < 6 Weeks	1% of milestone payment
	>= 6 to < 8 Weeks	2% of milestone payment
	8 Weeks	3% of milestone payment
	> 8 Weeks	Additional 1% for every week's delay beyond 8th week capped at 10% of total project CAPEX
If any of the Core Team Member is not available without intimation or timely replacement (Yearly Measurement - Penalty will be applied in second year's payments)	2 Occasions	No Penalty
	per Occasion	INR 50,000/-

Table 4: Implementation Stage SLA

**Note:-**

1. Only one replacement of per profile would be permitted per year. Replacement due to reason control of SI (like resignation of the resource, accident, etc.) would not be counted in the per replacement.

## 4. Operations Stage SLAs

### 4.2.1 Network related Operational Service levels

Sl. No.	Measurement	Definition	Monthly Target	Penalty as % of QGR
1	Availability of NOC & Core PoPs	All the Network Equipment installed and commissioned at NOC and core PoPs	≥99.99 %	No Penalty
			≥99.5 % to <99.99 %	2.00%
			≥99.0 % to <99.5 %	5.00%
			<99.0 %	Additional 1% penalty on account of each 0.1% reduction in uptime
2	Network Availability at Aggregation PoPs	<p>Network Availability (%) for a month = (Total minutes during the month – Downtime minutes during the month) *100 / Total minutes during the month.</p> <p>Network Equipment Availability for a month = Total time (in minutes) in a month - total down time (in minutes) in a month</p> <p>The network is considered available when all the services in full capacity are available.</p>	≥99.5 %	No Penalty
			≥99.3 % to <99.5 %	2.00%
			≥99.0 % to <99.3 %	5.00%
			<99.0 %	Additional 1% penalty on account of each 0.2% reduction in uptime
3	Network Availability at Pre-Aggregation PoPs	<p>Total Time shall be measured on 24*7 basis.</p> <p>The downtime of the Aggregation, Pre-Aggregation, Spur PoPs and Access locations commissioned during the implementation phase shall be calculated on prorata basis.</p> <p>Measurement Tool: Reports from EMS duly approved by the Authority or its appointed agency. SI shall submit quarterly reports on the performance and adherence to the SLA</p>	≥99.4 %	No Penalty
			≥99.2 % to <99.4 %	2.00%
			≥99.0 % to <99.2%	5.00%
			< 99.0%	Additional 1% penalty on account of each 0.2% reduction in uptime
4	Network Availability at Spur PoPs	<p>The SLA for end office locations shall be measured from the time of the call being registered at help desk</p>	≥99.3 %	No Penalty
			≥99.1 % to <99.3 %	2.00%
			≥99.0 % to <99.1%	5.00%
			< 99.0%	Additional 1% penalty on account of each

SI. No.	Measurement	Definition	Monthly Target	Penalty as % of QGR
				0.2% reduction in uptime
5	Access locations		≥99.0 %	No Penalty
			≥98.0% to <99.0%	1.00%
			≥97.0 % to <98.0%	3.00%
			≥96.0 % to <97.0%	5.00%
			< 96.0%	Additional 1% penalty on account of each 0.5% reduction in uptime
6	Network backbone packet loss	Monthly Reports from NMS	Up to 1%	No Penalty
			More than 1%	0.5% penalty on account of each 1% additional packet loss
7	Network latency/Jitter (Core to Access)	Monthly Reports from NMS	Up to 40 ms	No Penalty
			More than 40 ms	0.5% penalty on account of each 5ms additional latency

Table 5: Network related operational SLAs

**Note:** During the post-implementation period, in case any field equipment is damaged by a vehicular accident (or due to other reason outside the control of SI) and needs repair/replacement, then the corresponding equipment to be replaced as per the SLAs defined in this section. In such cases, damages are to be borne by SI through proper comprehensive insurance for all the equipment during contract period.

4.2.1.1 **Link Margin Values degradation in ring topology of DWDM network on monthly basis**

SL	KPI Value	Penalty
1	4 dB	Nil
2	3 dB	INR 5,000 per dB
3	2 dB	INR 10,000 per dB
4	0 dB and Below	INR 20,000 per dB

Table 6: Link Margin Values Degradation in DWDM network

4.2.2 Helpdesk SLA

Service	Measurement	Definition	Target	Penalty as % of QGR
Incident Reporting	Any failure/incident on any part of the network infrastructure or its facilities shall be communicated	Reports generated from Ticket logging system	100% incidents to be reported within 1 hour with the cause, action and remedy for the incident.	No Penalty



Service	Measurement	Definition	Target	Penalty as % of QGR
	immediately to Helpdesk as an exceptional report giving details of downtime if any.		Delay beyond an hour	INR 100 for every hour's delay on an incremental basis.
100% incident log to be submitted that comprises exceptional & normal reportable activities by 5th of every Quarter for the previous quarter.			No Penalty	
Delay beyond the date of submission of log			INR 1,000 for every day's delay on an incremental basis	

Table 7: Helpdesk SLA

4.2.2.1 **Failure Resolution**

Sl. No.	Mean Value in a Quarter	Penalty (% of O&M)
MTTR - Network restoration	< 4 hrs.	No Penalty
	>= 4hrs. and <8 hrs.	1
	>= 8hrs. and <16 hrs.	2
	>= 16hrs. and <24 hrs.	3
	> 24 hrs.	5
MTTR - Fibre Restoration	< 8 hrs.	No Penalty
	>= 8 hrs. and <12 hrs.	1
	>= 12 hrs. and <18 hrs.	2
	>= 18 hrs. and <24 hrs.	3
	> 24 hrs.	5

Table 8: Failure Resolution SLA

**4.3 Service Levels Monitoring**

The Service Level parameters defined shall be monitored on a periodic basis, as per the individual parameter requirements. SI shall be responsible for providing appropriate web based online SLA measurement and monitoring tools for the same. These tools are subject to an independent audit by any agency appointed by Authority. SI is obliged to provide to these agencies any reports/support /access to these tools as requested by the SI shall be expected to take immediate corrective action for any breach in SLA. SI will provide support for any independent audit of the SLA tools/reports.

**4.4 Reporting Procedures**

SI representative shall prepare and distribute Service level performance reports in a mutually agreed format by the 5th working day of subsequent month. The reports shall include “actual versus target” Service Level Performance, a variance analysis and discussion of appropriate issues or significant events. Performance reports shall be distributed to Project Management Unit (PMU).

Also, SI may be required to get the Service Level performance report audited by the agency appointed by Authority

**4.5 Exclusions**

For the purpose of calculating SLA, the following faults or outage hours shall be excluded:

## Volume- I

---

1. Periods where the State/Authority office staff is inaccessible to confirm the status of the system after fault clearance by the SI
2. Periods where any link is switched off at State / Authority or Govt. Office due its own reasons. The onus lies on State / Authority or respective Govt. establishment to ensure that the on-site equipment are powered ON and / or the Network Monitoring tools, if any, that are used by State / Authority should be able to filter out the time period of link being voluntarily switched off from the down time calculations.
3. Periods where the failure of any components or equipment belonging to State / Authority / Govt. office.

## 5 Evaluation Framework

### 5.1 Three Stage Bid System

- Complete bidding process will be online (e-tendering) in three stage –bid system. All the notification and details terms and conditions regarding, this tender notice hereafter will be published on line on the website <https://etenders.kerala.gov.in/>
- Bidders can login to e-procurement –portal in secure mode only by signing through the Digital certificates.
- Bidder should submit all the required information / documentation, as specified in the Tender Document, in PDF format.
- The bidders shall sign on all the statements, documents, certificates uploaded by them, owning responsibility for their correctness/ authenticity.
- Pre-Qualification bids will be opened online on website <https://etenders.kerala.gov.in/> as per the timeline specified in e-tender website
- The rates should be quoted in the Commercial Bid format attached with the tender and uploaded online as per the instructions given on the web site <https://etenders.kerala.gov.in/>
- The Authority reserves the right to accept or reject any or all the tenders without assigning any reason.

The three stage-Bid to be submitted by the Bidder shall consist of minimum following:

<p><b>Pre-Qualification Bid</b></p>	<ul style="list-style-type: none"> <li>• Bidder’s response to the Pre-Qualification Criteria defined in this section of this Tender.</li> <li>• The Pre-Qualification related documentation shall be prepared in accordance with the requirements specified in this Tender and in the formats prescribed in the Tender Document.</li> <li>• Pre-Qualification Bid should not contain commercials of the Project, in either explicit or implicit form.</li> <li>• Pre-qualification Bid should be submitted along with a certified true copy of a board resolution/power of attorney empowering authorized signatory to sign/act/execute documents binding the Bidder organization to the terms and conditions detailed in this proposal.</li> </ul>
<p><b>Technical Bid</b></p>	<ul style="list-style-type: none"> <li>• The Technical Bid shall be prepared in accordance with the requirements specified in this Tender and in the formats prescribed in the Tender Document.</li> <li>• Technical Bid should not contain commercials of the Project, in either explicit or implicit form.</li> <li>• Conditional Technical Bid is liable for rejection.</li> <li>• Since the size of the Technical Bid is expected to be quite large, bidders are advised to upload the technical documents well in advance and do not wait for last minute.</li> </ul>
<p><b>Commercial Bid</b></p>	<ul style="list-style-type: none"> <li>• Forms and formats specified on the e-Tender website need to be scrupulously followed. Any deviation in it (without proper justification) may lead to disqualification of the Bid.</li> <li>• Price quotation accompanied by vague and conditional expressions such as "subject to immediate acceptance", "subject to confirmation", etc. will be treated as being at variance and shall be liable to be summarily rejected.</li> </ul>

Authority will not accept submission of a bid in any manner other than that specified in the Tender Document. Bids submitted in any other manner shall be treated as defective, invalid and rejected.

Bids must be direct, concise, and complete. Authority will evaluate Bidder's bid based on its clarity and completeness of its response to the requirements of the project as outlined in this Tender.

## 5.2 Pre-Qualification Criteria

SL No.	Parameter	Criteria	Proof
1.	Legal Entity	<p>The Bidder (Lead Bidder in case of a consortium) must be a registered company in India, registered under the Companies Act 1956. In case of a consortium, the members (other than Lead Bidder) shall be a registered legal entity.</p> <p>The Bidder(all members in case of a consortium) should be operating in India for the last seven years as on 31/03/2018</p>	<ul style="list-style-type: none"> <li>• Incorporation Certificate issued by MCA for company registration</li> <li>• Certificate of registration issued by competent authority</li> <li>• Income Tax/PAN Registration</li> <li>• GST Registration</li> <li>• Audited Balance Sheets for the past seven years/Work orders showing operations for each of the past seven years</li> <li>• Above documents to be submitted by all members in case of a consortium</li> </ul>
2.	Consortium	<p><b>Consortium is allowed.</b> Maximum number of members allowed in a consortium is <b>Three (3)</b> including Lead member.</p> <p>The parties shall have a valid agreement among them. The agreement shall clearly specify the following:-</p> <ul style="list-style-type: none"> <li>- Details of Lead member and other consortium members</li> <li>- Outline the financial strengths, technical strengths and the role and responsibility(s) of each of the members of the consortium.</li> <li>- Invoices shall be raised by Lead Bidder and payment shall be given only to the Lead Bidder.</li> <li>- Power of Attorney (POA) shall be in favor of the Lead Member.</li> <li>- All parties shall sign the Agreement with the Authority on award of work.</li> <li>- Lead Bidder will be a Systems Integrator</li> </ul> <p><b>Lead Bidder should have a stake of at least 50% of the Total Contract Value among the consortium member. The stake should be clearly mentioned in the Consortium Agreement.</b></p> <p>Notwithstanding the foregoing, the Lead Bidder shall be responsible and liable for entire scope of work. Lead Bidder will have agreement with the consortium members and the same shall be shared with the Authority</p>	<ul style="list-style-type: none"> <li>• Consortium Agreement</li> <li>• Should be attested by a notary</li> <li>• Documents to show Consortium Members authorized signatory's authority to sign such POA.</li> </ul>

SL No.	Parameter	Criteria	Proof
3.	Financial Capability	<p>The average annual turnover of the last three years (FY 15-16, FY 16-17, FY 17-18) for the Bidder (Lead Bidder in case of consortium) should be minimum <b>INR 800 Crores</b> of which average annual turnover from Network/Telecom/ICT/IT infrastructure projects in last three years (FY 15-16, FY 16-17, FY 17-18) should be minimum <b>INR 400 Crores</b></p> <p>In case of a consortium, the average annual turnover of each of the consortium members (other than the Lead Bidder) for the last three years (FY 15-16, FY 16-17, FY 17-18) should be minimum <b>INR 100 Crores</b> in their chosen field</p>	<ul style="list-style-type: none"> <li>CA certificate stating the overall turnover details and turnover from Network/Telecom/ICT/IT Infrastructure projects for the last three years (FY 15-16, FY 16-17, FY 17-18) with name, seal and registration number of CA</li> <li>Audited Balance Sheets and Profit &amp; Loss Statements for the FY 15-16, FY 16-17, FY 17-18</li> </ul>
4.	Net worth	<p>The Bidder (Lead Bidder in case of a consortium) should have <b>positive net worth</b> as on 31/03/2018</p> <p>Consortium members should also have a <b>positive net worth</b></p> <p>Bidder (Lead Bidder in case of a consortium) shall furnish a solvency certificate by any Scheduled Commercial Bank/Nationalized Bank for minimum <b>INR 400 Crores</b></p>	<ul style="list-style-type: none"> <li>CA certificate stating the net-worth as on 31/03/2018 with name, seal and registration number of CA</li> <li>Audited Balance Sheets and Profit &amp; Loss Statements for the FY 15-16, FY 16-17, FY 17-18</li> </ul>
5.	Technical Capability	<p>Bidder (or any member of the consortium) should have completed aerial/underground fibre laying and installation for a minimum length of <b>1,500 kilometres in the last seven (7) years</b> in satisfactory operation for at least last one year as on the date of submission of bid</p> <p>Bidder (or any member of the consortium) should have the experience of at least <b>100 Kms of live line installation OPGW on 110kV or higher</b> voltage transmission line in India and which must be in satisfactory operation for at least one year as on the date of submission of bid</p>	<ul style="list-style-type: none"> <li>Copy of PO/Contract/Agreement with client</li> <li>Completion Letter</li> <li>Performance (incl. years of operation, quantity) certificates by the client on their letterhead</li> </ul>
6.	Technical Capability	<p>The Bidder (Lead Bidder in case of a consortium) should have completed <b>minimum two (2) telecom/network projects in the last seven (7) years</b> minimum project value <b>INR 100 Cr</b> each as on date of submission of bid</p> <p>Bidder (or any member of the consortium) should have completed <b>at least one (1) systems integration/ICT infrastructure services project</b> in India of minimum project value <b>INR 50 Cr</b> in the <b>last seven (7) years</b> as on the date of submission of bid</p>	<ul style="list-style-type: none"> <li>Copy of PO/Contract/Agreement with client</li> <li>Completion Letter</li> </ul>
7.	Quality Certification	<p>Bidder (Lead Bidder in case of a consortium) should have a valid ISO 9001:2000 or above and ISO 27001</p>	<ul style="list-style-type: none"> <li>Copy of Valid certification</li> </ul>
8.	Blacklisting	<p>Bidder (all members in case of a consortium) should not have been blacklisted by Central/State Government/PSU in India as on the date of Bid submission.</p>	<ul style="list-style-type: none"> <li>Self-certification on company letterhead by authorized signatory</li> <li>To be submitted by all the members of the consortium</li> </ul>

SL No.	Parameter	Criteria	Proof
9.	EMD		<ul style="list-style-type: none"> <li>Transaction reference number</li> </ul>
10.	Non-Refundable Document processing fees	RFP document fees	<ul style="list-style-type: none"> <li>Transaction reference number</li> </ul>
11.	POA/Board Resolution	POA and Board Resolution authorizing Lead member to sign the Bid Documents	<ul style="list-style-type: none"> <li>Documents to show Consortium Members authorized signatory's authority to sign such POA.</li> </ul>
12.	OFC (ADSS/UG)	The OFC manufacturer should have supplied a cumulative of at least <b>10,000 km of minimum of 48F and above</b> OFC to Private Telecom Operators/State/Central PSUs/Government Telecom Operators in India during the last <b>three(3) years</b> on date of submission of bid	<ul style="list-style-type: none"> <li>Copy of PO/Contract/Agreement with the client</li> <li>Certificate from client on their letterhead with details of quantity supplied.</li> </ul>
13.	OFC (ADSS/UG)	The OFC manufacturer should use ITU-T grade G.652.D and G.657.A1 optical fibre, sourced from CACT approved indigenous sources.	<ul style="list-style-type: none"> <li>CACT certificate to be submitted.</li> </ul>
14.	OFC (ADSS/UG)	The OFC manufacturer should have an after sales service centre / spare equipment depot with adequately trained manpower in India.	<ul style="list-style-type: none"> <li>Certificate on company letterhead signed by Managing Director / CEO mentioning the complete details of such centres / depots</li> </ul>
15.	OFC	The OFC manufacturer should not be blacklisted by any Central/ State/UT Government or Govt. PSU as on the date of submission of bid	<ul style="list-style-type: none"> <li>Self-Certification on company letterhead signed by company secretary / Managing Director / CEO</li> </ul>
16.	OPGW	OPGW (optical ground wire) shall be from an Indian Manufacturer, who should have designed, manufactured, tested (as per relevant IS/IEC/ Eq. Standards) and supplied 250Kms of OPGW in last 5 years out of which 100Kms should have been in satisfactory operation on 110kV class or above voltage grade line in India for a minimum period of 2 years as on date of submission of bid	<ul style="list-style-type: none"> <li>Copy of PO/Contract/Agreement with the client</li> <li>Performance (incl. years of operation, quantity) certificates by the client on their letterhead</li> </ul>
17.	OPGW	The OPGW manufacturer should have an after sales service centre / spare equipment depot with adequately trained manpower in India.	<ul style="list-style-type: none"> <li>Certificate on company letterhead signed by Managing Director / CEO mentioning the complete details of such centres / depots</li> </ul>
18.	Active	OEM should not be blacklisted by any Central/ State/UT Government or Govt. PSU as on the date of submission of bid	<ul style="list-style-type: none"> <li>Self-Certification on company letterhead signed by company secretary / Managing Director / CEO</li> </ul>
19.	Active	OEM should have supplied at least <b>500 IP/MPLS</b> edge/aggregation/core/access routers to Service Providers/ Central Govt. /State Govt./ PSUs in India <b>in the last two years</b> on date of submission of bid	<ul style="list-style-type: none"> <li>Copy of PO/Contract/Agreement with the client</li> </ul>

SL No.	Parameter	Criteria	Proof
20.	Active	OEM should have supplied at least of <b>50 Nos. of DWDM equipment</b> (Wavelength Selective Multiplexer (WDM)/Optical Add Drop Multiplexer (OADM)/ROADM, OTN) to Service Providers/ Central Govt. /State Govt./ PSUs in India <b>in the last two years</b> as on date of submission of bid	<ul style="list-style-type: none"> <li>Copy of PO/Contract/Agreement with the client</li> </ul>
21.	Active	OEM should have an after sales service centre / spare equipment depot with adequately trained manpower in India.	<ul style="list-style-type: none"> <li>Certificate on company letterhead signed by Managing Director / CEO mentioning the complete details of such centres / depots</li> </ul>
22.	GPON	OEM should have supplied at least of <b>1,000 Nos. of OLT and 10,000 Nos. of ONT equipment</b> to Service Providers/ Central Govt. /State Govt./ PSUs in India <b>in the last years</b> as on date of submission of bid	<ul style="list-style-type: none"> <li>Copy of PO/Contract/Agreement with the client</li> </ul>
23.	GPON	OEM should have an after sales service centre / spare equipment depot with adequately trained manpower in India.	<ul style="list-style-type: none"> <li>Certificate on company by Managing Director / CEO mentioning the complete details of such centres / depots</li> </ul>
24.	GPON	OEM should not be blacklisted by any Central/ State/UT Government or Govt. PSU as on the date of submission of bid	<ul style="list-style-type: none"> <li>Self-Certification on company letterhead signed by company secretary / Managing Director / CEO</li> </ul>
25.	Project Office	The Bidder (Lead Bidder in case of consortium), should have a project office in Thiruvananthapuram. However, if the local presence is not there in Thiruvananthapuram, the selected Bidder should provide an undertaking for establishment of a project office, within 30 days of award of the contract.	<ul style="list-style-type: none"> <li>Self-Certification on company letterhead signed by Managing Director / CEO</li> <li>Address proof (in case if its existing)</li> </ul>

Table 9: Pre-Qualification Criteria

**Note:-**

1. Successful Bidder or any of its consortium members or their sister concerns cannot be the PM for the project
2. Bidder company turnover would be considered for only 100% subsidiary/ division/sub-division business unit. In case the Bidder is a subsidiary company, the parent company's financials shall be considered.
3. The financial turnover means revenue excluding non-recurring income, income from other stocks and shares. "Income" in an audited Profit and Loss Account will be considered. Closing stocks in warehouse manner should not form part of turnover.
4. Foreign currency Turnover will be converted into Indian Rupees based on RBI reference rate as on the date of opening of proposals without assigning any weightage factor.
5. An entity is permitted to participate as a member of more than one Consortium for a particular work. But Lead Bidder shall submit only one bid for the work. He shall not be a member in any other Consortium for the same work.
6. The Lead Bidder shall be designated in the Consortium agreement to be submitted along with the bid. The Lead Bidder shall have the authority to conduct all business for and to act on behalf of all partners of the Consortium, during the bidding process and in the event the contract is awarded.
7. The Lead Bidder shall be responsible for submission of bid and complete information required in the prescribed formats, pertaining to each firm in the Consortium and completion of contract.

*and to furnish evidences admissible as per law. The Lead Bidder shall clearly identify the responsibilities of other members of the Consortium.*

*8. The performance relating to previous contracts executed by the Bidder/consortium shall be satisfactory.*

*9. The bidder has to submit all the documents, mentioned elsewhere in the tender document, together during bid submission itself to prove their pre-qualification. **If the required documents are not submitted along with the bid, the bid shall be liable to get rejected.***

### **5.3 Qualifying Criteria for Technical Bid**

Prior to the detailed evaluation of the Technical Bids, Authority shall determine whether each Bid is

- complete,
- is accompanied by the required information and documents and
- is substantially responsive to the requirements set forth in the Tender Documents.

Authority has formed a Technical Committee, which will evaluate both technical and commercial bids received in response to this Tender. The findings of the said Committee and subsequent decision of State Government shall be final and binding on all the bidders. Only those Bidders, who fulfil all the criteria / requirements mentioned in the Tender, shall be eligible and qualified for technical scrutiny as per the Technical Evaluation Framework given below.

**Bidders should obtain minimum 70 marks in the overall technical evaluation and should obtain minimum 70 marks in each sub category, to qualify for opening of the Commercial Bid.** The Commercial Bid evaluation in this regard shall be final and binding on the Bidder.

Authority may in its sole discretion, waive any informality or non-conformity or irregularity in a bid document, which does not constitute a material deviation, provided such a waiver does not prejudice or affect the relative ranking of any Bidder.



## 5.4 Technical Bid Evaluation

SL No.	Criteria	Marks	Proof								
<b>A. Organizational Strength</b>		<i>Max = 15</i>									
1.	Turnover of the Lead Bidder	<table border="1"> <thead> <tr> <th>Turnover</th> <th>Marks</th> </tr> </thead> <tbody> <tr> <td>800-1,000 Cr</td> <td>2 Mark</td> </tr> <tr> <td>1,000 – 1,200 Cr</td> <td>3.5 Marks</td> </tr> <tr> <td>&gt; 1,200 Cr</td> <td>5 Marks</td> </tr> </tbody> </table>	Turnover	Marks	800-1,000 Cr	2 Mark	1,000 – 1,200 Cr	3.5 Marks	> 1,200 Cr	5 Marks	Audited Balance Sheets and Profit & Loss Statements for the FY 15-16, FY 16-17, FY 17-18
Turnover	Marks										
800-1,000 Cr	2 Mark										
1,000 – 1,200 Cr	3.5 Marks										
> 1,200 Cr	5 Marks										
2.	Years of Operation of the Lead Bidder	<table border="1"> <thead> <tr> <th>Years of Operation</th> <th>Marks</th> </tr> </thead> <tbody> <tr> <td>7-8 Years</td> <td>2 Mark</td> </tr> <tr> <td>8-10 Years</td> <td>3.5 Marks</td> </tr> <tr> <td>&gt;10 Years</td> <td>5 Marks</td> </tr> </tbody> </table>	Years of Operation	Marks	7-8 Years	2 Mark	8-10 Years	3.5 Marks	>10 Years	5 Marks	Audited Balance sheets and Profit & Loss Statements
Years of Operation	Marks										
7-8 Years	2 Mark										
8-10 Years	3.5 Marks										
>10 Years	5 Marks										
3.	Qualified Professionals on Roll of the Lead Bidder	<table border="1"> <thead> <tr> <th>Staff</th> <th>Marks</th> </tr> </thead> <tbody> <tr> <td>500-750</td> <td>2 Mark</td> </tr> <tr> <td>750-1,000</td> <td>3.5 Marks</td> </tr> <tr> <td>&gt;1,000</td> <td>5 Marks</td> </tr> </tbody> </table>	Staff	Marks	500-750	2 Mark	750-1,000	3.5 Marks	>1,000	5 Marks	Self-Certificate from Authorized signatory
Staff	Marks										
500-750	2 Mark										
750-1,000	3.5 Marks										
>1,000	5 Marks										
<b>B. Technical Presentation</b>		<i>Max = 30</i>	<i>Cut off = 15</i>								
<b>Work Plan and Staffing</b>											
4.	Team adequacy and staffing to meet implementation timelines										
5.	Team adequacy and staffing to meet operational SLAs										
6.	Project Management Structure and Methodology										
7.	Mitigation of time over-runs										
<b>Approach and Methodology</b>											
8.	Understanding of scope and objectives										
9.	Fibre Commissioning Methodology										
10.	Testing and QA										
11.	SLA monitoring and Management										
12.	Scalability of proposed soln.										
13.	Manageability of network, users, usage										
14.	Project Governance										
15.	Enhanceability of Features & Functions										
16.	Risk Identified and Mitigation Proposed										
17.	Comments on the Terms of Reference										
<b>C. Past Experience</b>		<i>Max = 50</i>									

SL No.	Criteria	Marks	Proof																								
18.	Optical Fibre Commissioning projects completed in last ten(10) years as on date of submission of bid	<table border="1"> <thead> <tr> <th>OPGW</th> <th>Marks</th> </tr> </thead> <tbody> <tr> <td>100-300 Km</td> <td>4 Mark</td> </tr> <tr> <td>300 – 500 Km</td> <td>6 Marks</td> </tr> <tr> <td>&gt; 500 Km</td> <td>8 Marks</td> </tr> </tbody> </table> <table border="1"> <thead> <tr> <th>ADSS</th> <th>Marks</th> </tr> </thead> <tbody> <tr> <td>100-500 Km</td> <td>4 Mark</td> </tr> <tr> <td>500-1,000 Km</td> <td>6 Marks</td> </tr> <tr> <td>&gt;1,000 Km</td> <td>8 Marks</td> </tr> </tbody> </table> <table border="1"> <thead> <tr> <th>UG Cabling</th> <th>Marks</th> </tr> </thead> <tbody> <tr> <td>1,000-2,000 Km</td> <td>4 Marks</td> </tr> <tr> <td>2,000-5,000 Km</td> <td>6 Marks</td> </tr> <tr> <td>&gt;5,000 Km</td> <td>8 Marks</td> </tr> </tbody> </table>	OPGW	Marks	100-300 Km	4 Mark	300 – 500 Km	6 Marks	> 500 Km	8 Marks	ADSS	Marks	100-500 Km	4 Mark	500-1,000 Km	6 Marks	>1,000 Km	8 Marks	UG Cabling	Marks	1,000-2,000 Km	4 Marks	2,000-5,000 Km	6 Marks	>5,000 Km	8 Marks	PO/Contract and completion certificate
OPGW	Marks																										
100-300 Km	4 Mark																										
300 – 500 Km	6 Marks																										
> 500 Km	8 Marks																										
ADSS	Marks																										
100-500 Km	4 Mark																										
500-1,000 Km	6 Marks																										
>1,000 Km	8 Marks																										
UG Cabling	Marks																										
1,000-2,000 Km	4 Marks																										
2,000-5,000 Km	6 Marks																										
>5,000 Km	8 Marks																										
19.	Network/ Telecom Projects completed in the last seven(7) years as on date of submission of bid with value more than INR Fifty(50) crores	<table border="1"> <thead> <tr> <th>Network/ Telecom Projects</th> <th>Marks</th> </tr> </thead> <tbody> <tr> <td>2-3</td> <td>5 Marks</td> </tr> <tr> <td>4-5</td> <td>7 Marks</td> </tr> <tr> <td>&gt; 5</td> <td>10 Marks</td> </tr> </tbody> </table> <table border="1"> <thead> <tr> <th>NOC setup</th> <th>Marks</th> </tr> </thead> <tbody> <tr> <td>2-3</td> <td>4 Marks</td> </tr> <tr> <td>4-5</td> <td>6 Marks</td> </tr> <tr> <td>&gt;5</td> <td>8 Marks</td> </tr> </tbody> </table>	Network/ Telecom Projects	Marks	2-3	5 Marks	4-5	7 Marks	> 5	10 Marks	NOC setup	Marks	2-3	4 Marks	4-5	6 Marks	>5	8 Marks	PO/Contract and completion certificate								
Network/ Telecom Projects	Marks																										
2-3	5 Marks																										
4-5	7 Marks																										
> 5	10 Marks																										
NOC setup	Marks																										
2-3	4 Marks																										
4-5	6 Marks																										
>5	8 Marks																										
20.	Operations & Management of fibre network / Telecom projects completed in the last seven(7) years as on date of submission of bid with value more than INR five(5) crores	<table border="1"> <thead> <tr> <th>No. of Projects</th> <th>Marks</th> </tr> </thead> <tbody> <tr> <td>1-2</td> <td>4 Marks</td> </tr> <tr> <td>&gt;2</td> <td>8 Marks</td> </tr> </tbody> </table>	No. of Projects	Marks	1-2	4 Marks	>2	8 Marks	PO/Contract and completion certificate																		
No. of Projects	Marks																										
1-2	4 Marks																										
>2	8 Marks																										
<b>D. Relevant Experience with Centre/State/UT Government/PSU</b>		<table border="1"> <tr> <td>Max = 5</td> <td>Min = 2</td> </tr> </table>	Max = 5	Min = 2																							
Max = 5	Min = 2																										
21.	Number of completed projects	1 Mark per project	PO/Contract																								

Table 10: Technical Evaluation Criteria

### 5.5 Commercial Bid Evaluation

Evaluation of bids shall be done on **Least Cost/Lowest Cost (L1) criteria**. The bidders who have obtained a **minimum of 70 marks in the technical evaluation** are considered for commercial bid evaluation. Commercial Evaluation shall be done on **Net Present Value (NPV) discounting at the rate of 10%**.

Formula for calculating L1 is as follows:

$$X1 = \text{CAPEX of Package A (without tax)}$$

$$X2 = \text{CAPEX of Package B (without tax)}$$

$$X3 = X1 + X2$$

Y1 = OPEX for year 1 (without tax)

Y2 = OPEX for year 2 (without tax)

...

Y7 = OPEX for year 7 (without tax)

Total Bid value,  $Z = NPV = C1/(1+r) + C2/(1+r)^2 + C3/(1+r)^3 + \dots + C9/(1+r)^9$

Where  $C1 = X3/2$ ;  $C2 = X3/2$ ;  $C3 = Y1$ ; ...  $C9 = Y7$ ,  $r = 10\%$

**The Bidder who has lowest value of Z will be declared as L1.**

## **5.6 Rejection Criteria**

Besides other conditions and terms highlighted in the Tender Document, bids may be rejected under following circumstances:

### **5.6.1 General rejection criteria**

- a) Conditional Bids;
- b) If the information provided by the Bidder is found to be incorrect / misleading / fraudulent at any stage / time during the Tendering Process;
- c) Any effort on the part of a Bidder to influence the bid evaluation, bid comparison or contract award decisions;
- d) Bids received after the prescribed time and date for receipt of bids;
- e) Bids without signature of person (s) duly authorized on required pages of the bid;
- f) Bids without power of attorney/ board resolution;
- g) Any other reasons mentioned in this RfP elsewhere

### **5.6.2 Pre-Qualification Rejection Criteria**

- a) Bidders not complying with the Pre-Qualification Criteria given in this Tender
- b) Pre-Qualification Envelope containing commercial details;
- c) Revelation of Prices in any form or by any reason before opening the Commercial Bid;
- d) Failure to furnish all information required by the Tender Document or submission of a Bid not substantially responsive to the Tender Document in every respect;
- e) Any other reasons mentioned in this RfP elsewhere

### **5.6.3 Technical Rejection Criteria**

- a) Technical Bid containing commercial details;
- b) Revelation of prices in any form or by any reason before opening the Commercial Bid;
- c) Failure to furnish all information required by the Tender Document or submission of a bid not substantially responsive to the Tender Document in every respect;

- d) Bidders not quoting for the complete scope of work as indicated in the Tender Documents, addendum (if any) and any subsequent information given to the Bidder;
- e) Bidders not complying with the technical and general terms and conditions as stated in the Tender Documents;
- f) Bidder not confirming unconditional acceptance of full responsibility of providing services in accordance with the scope of work and Service Level Agreements of this tender;
- g) Any other reasons mentioned in this RfP elsewhere

**5.6.4 Commercial Rejection Criteria**

- a) Incomplete Price Bid;
- b) Price Bids that do not conform to the Tender's price bid format;
- c) Total price quoted by the Bidder does not include all statutory taxes and levies applicable;
- d) If there is an arithmetic discrepancy in the commercial Bid calculations the Technical Committee shall rectify the same. If the Bidder does not accept the correction of the errors, its bid may be rejected;
- e) If there is discrepancy in numerical and words, prices in word shall prevail;
- f) If there is discrepancy in unit rates and total, unit rates shall prevail

## 6 Prequalification Bid Formats

### 6.1 PQ Format 1 - Prequalification Bid Checklist

#	Documents to be submitted	Submitted (Y / N)	Documentary Proof
1.	RFP Document Fees		Transaction Ref No.
2.	Earnest Money Deposit		Transaction Ref No.
3.	PQ Format 2 - Bid Covering Letter		
4.	PQ Format 3 - Bidder Profile		
5.	PQ Format 4 – PQ Criteria Compliance & Supporting Documents		
6.	PQ Format 5 - Format for Power Attorney to Authorize Signatory		
7.	PQ Format 6 - Format for Power Attorney to Authorize Lead Bidder		
8.	PQ Format 7 – Certificate of Non-Blacklisting		
9.	PQ Format 8 – Self Declaration		
10.	PQ Format 9 – NDA		

*Table 11: Prequalification Bid Checklist*

## 6.2 PQ Format 2 - Prequalification Cover Letter

[To Be Furnished on the Letterhead of the Lead Bidder]

To

Managing Director,  
Kerala State Information Technology Infrastructure Ltd., TC No.: 14/196/2, 3rd Floor,  
Chandrasekharan Nair Stadium,  
Palayam, Trivandrum - 695033

**Subject:** RFP for Selection of an Agency for Implementation of Kerala Fibre Optic Network and Reliable Communication & Data Acquisition Network

**Ref:** Tender No: **KSITIL/MD/KFON/18/1852: 14/06/2018**

Sir/ Madam,

Having examined the Tender, the receipt of which is hereby duly acknowledged, we, the undersigned, offer to provide the professional services as required and outlined in the Tender.

We attach here to our responses to pre-qualification requirements and Technical & Commercial Bids as required by the Tender. We confirm that the information contained in these responses or any part thereof, including the exhibits, and other documents and instruments delivered or to be delivered to the Authority is true, accurate, verifiable and complete. This response includes all information necessary to ensure that the statements therein do not in whole or in part mislead the department in its short-listing process.

We fully understand and agree to comply that on verification, if any of the information provided here is found to be misleading the selection process, we are liable to be dismissed from the selection process or termination of the contract during the project, if selected to do so.

We agree for unconditional acceptance of all the terms and conditions set out in the Tender Document and also agree to abide by this tender response for a period of 180 days from the date fixed for bid opening. We hereby declare that in case the contract is awarded to us, we shall submit the contract performance guarantee bond in the form prescribed the Tender. We also herewith express our willingness to subject to Authority's conditionality regarding manpower recruitments (required for the project), change of hands of management and declaring upfront the source of funding for the project.

We agree that you are not bound to accept any tender response you may receive. We also agree that you reserve the right in absolute sense to reject all or any of the products/ services specified in the tender response.

It is hereby confirmed that I/We are entitled to act on behalf of our company/ corporation/ firm/ organization and empowered to sign this document as well as such other documents, which may be required in this connection.

Signature:

**Name & Title of the Signatory:**

**Name & Address of the Entity:**

**Place:**

**Date:**

**Seal:**

### 6.3 PQ Format 3 - Bidder Profile

#	Description	Details (to be filled by the responder to the Tender)
1.	Name of the company	
2.	Official address	
3.	Phone No. and Fax No.	
4.	Corporate Headquarters Address	
5.	Phone No. and Fax No.	
6.	Website	
7.	GST registration No.	
8.	Permanent Account Number (PAN)	
9.	Role in the Consortium (if applicable)	
10.	Year wise turnover for the last three years (in INR Cr)	2015-16: 2016-17: 2017-18:
11.	Net Worth (in INR Cr)	
12.	Primary contact details of officials for future correspondence regarding the bid process	Name Title Company Address Phone Mobile Fax E-mail
13.	Secondary contact details of officials for future correspondence regarding the bid process	Name Title Company Address Phone Mobile Fax E-mail

Table 12: Bidder Profile

**Note:**

1. To be submitted by each of the Consortium members, in case of a consortium

**6.4 PQ Format 4 - Pre-Qualification Criteria Compliance**

SL No.	Parameter	Criteria	Proof
1.	Legal Entity	<p>The Bidder (Lead Bidder in case of a consortium) must be a registered company in India, registered under the Companies Act 1956. In case of a consortium, the members (other than Lead Bidder) shall be a registered legal entity.</p> <p>The Bidder(all members in case of a consortium) should be operating in India for the last seven years as on 31/03/2018</p>	<ul style="list-style-type: none"> <li>•</li> </ul>
2.	Consortium	<p><b>Consortium is allowed.</b> Maximum number of members allowed in a consortium is <b>Three (3)</b> including Lead member.</p> <p>The parties shall have a valid agreement among them. The agreement shall clearly specify the following:-</p> <ul style="list-style-type: none"> <li>- Details of Lead member and other consortium members</li> <li>- Outline the financial strengths, technical strengths and the role and responsibility(s) of each of the members of the consortium.</li> <li>- Invoices shall be raised by Lead Bidder and payment shall be given only to the Lead Bidder.</li> <li>- Power of Attorney (POA) shall be in favor of the Lead Member.</li> <li>- All parties shall sign the Agreement with the Authority on award of work.</li> <li>- Lead Bidder will be a Systems Integrator</li> </ul> <p><b>Lead Bidder should have a stake of at least 50% of the Total Contract Value among the consortium member. The stake should be clearly mentioned in the Consortium Agreement.</b></p> <p>Notwithstanding the foregoing, the Lead Bidder shall be responsible and liable for entire scope of work. Lead Bidder will have agreement with the consortium members and the same shall be shared with the Authority</p>	<ul style="list-style-type: none"> <li>•</li> </ul>
3.	Financial Capability	<p>The average annual turnover of the last three years (FY 15-16, FY 16-17, FY 17-18) for the Bidder (Lead Bidder in case of consortium) should be minimum <b>INR 800 Crores</b> of which average annual turnover from Network/Telecom/ICT/IT infrastructure projects in last three years (FY 15-16, FY 16-17, FY 17-18) should be minimum <b>INR 400 Crores</b></p> <p>In case of a consortium, the average annual turnover of each of the consortium members(other than the Lead Bidder) for the last three years (FY 15-16, FY 16-17, FY 17-18) should be minimum <b>INR 100 Crores</b> in their chosen field</p>	<ul style="list-style-type: none"> <li>•</li> </ul>



SL No.	Parameter	Criteria	Proof
4.	Net worth	The Bidder (Lead Bidder in case of a consortium) should have <b>positive net worth</b> as on 31/03/2018  Consortium members should also have a <b>positive net worth</b>  Bidder (Lead Bidder in case of a consortium) shall furnish a solvency certificate by any Scheduled Commercial Bank/Nationalized Bank for minimum <b>INR 400 Crores</b>	•
5.	Technical Capability	Bidder (or any member of the consortium) should have completed aerial/underground fibre laying and installation for a minimum length of <b>1,500 kilometres in the last seven (7) years</b> in satisfactory operation for at least last one year as on the date of submission of bid  Bidder (or any member of the consortium) should have the experience of at least <b>100 Kms of live line installation OPGW on 110kV or higher</b> voltage transmission line in India and which must be in satisfactory operation for at least one year as on the date of submission of bid	•
6.	Technical Capability	The Bidder (Lead Bidder in case of a consortium) should have completed <b>minimum two (2) telecom/network projects in the last seven (7) years</b> minimum project value <b>INR 100 Cr</b> each as on date of submission of bid  Bidder (or any member of the consortium) should have completed <b>at least one (1) systems integration/ICT infrastructure services project</b> in India of minimum project value <b>INR 50 Cr</b> in the <b>last seven (7) years</b> as on date of submission of bid	•
7.	Quality Certification	Bidder (Lead Bidder in case of a consortium) should have a valid ISO 9001:2000 or above and ISO 27001	•
8.	Blacklisting	Bidder (all members in case of a consortium) should not have been blacklisted by Central/State Government/PSU in India as on the date of Bid submission.	•
9.	EMD		•
10.	Non-Refundable Document processing fees	RFP document fees	•
11.	POA/Board Resolution	POA and Board Resolution authorizing Lead member to sign the Bid Documents	•
12.	OFC (ADSS/UG)	The OFC manufacturer should have supplied a cumulative of at least <b>10,000 km of minimum of 48F and above</b> OFC to Private Telecom Operators/State/Central PSUs/Government Telecom Operators in India during the last <b>three (3) years</b> as on date of submission of bid	•

SL No.	Parameter	Criteria	Proof
13.	OFC (ADSS/UG)	The OFC manufacturer should use ITU-T grade G.652.D and G.657.A1 optical fibre, sourced from CACT approved indigenous sources.	•
14.	OFC (ADSS/UG)	The OFC manufacturer should have an after sales service centre / spare equipment depot with adequately trained manpower in India.	•
15.	OFC	The OFC manufacturer should not be blacklisted by any Central/ State/UT Government or Govt. PSU as on the date of submission of bid	•
16.	OPGW	OPGW (optical ground wire) shall be from an Indian Manufacturer, who should have designed, manufactured, tested (as per relevant IS/IEC/ Eq. Standards) and supplied 250Kms of OPGW in last 5 years out of which 100Kms should have been in satisfactory operation on 110kV class or above voltage grade line in India for a minimum period of 2 years as on date of submission of bid	•
17.	OPGW	The OPGW manufacturer should have an after sales service centre / spare equipment depot with adequately trained manpower in India.	•
18.	Active	OEM should not be blacklisted by any Central/ State/UT Government or Govt. PSU as on the date of submission of bid	•
19.	Active	OEM should have supplied at least <b>500 IP/MPLS</b> edge/aggregation/core/access routers to Service Providers/ Central Govt. /State Govt./ PSUs in India <b>in the last two years</b> as on date of submission of bid	•
20.	Active	OEM should have supplied at least of <b>50 Nos. of DWDM equipment</b> (Central/Optical Add Drop Multiplexer (OADM)/ROADM, OTN) to Service Providers/ Central Govt. /State Govt./ PSUs in India <b>in the last two years</b> as on date of submission of bid	•
21.	Active	OEM should have an after sales service centre / spare equipment depot with adequately trained manpower in India.	•
22.	GPON	OEM should have supplied at least of <b>1,000 Nos. of OLT and 0,000 Nos. of ONT equipment</b> to Service Providers/ Central Govt. /State Govt./ PSUs in India <b>in the last years</b> as on date of submission of bid	•
23.	GPON	OEM should have an after sales service centre / spare equipment depot with adequately trained manpower in India.	•
24.	GPON	OEM should not be blacklisted by any Central/ State/UT Government or Govt. PSU as on the date of submission of bid	•
25.	Project Office	The Bidder (Lead Bidder in case of consortium), should have a project office in Thiruvananthapuram. However, if the local presence is not there in Thiruvananthapuram, the selected Bidder should provide an undertaking for establishment of a project office, within 30 days of award of the contract.	•

Table 13: Pre-qualification evaluation compliance

## 6.5 PQ Format 5 - Format for Power Attorney to Authorize Signatory

[To be executed on non-judicial stamp paper of the appropriate value in accordance with relevant Stamp Act. The stamp paper to be in the name of the company who is issuing the power of attorney.]

We, M/s. \_\_\_\_\_ (name of the firm or company with address of the registered office) hereby constitute, appoint and authorize Mr. or Ms. \_\_\_\_\_ (Name and residential address) who is presently employed with us and holding the position of \_\_\_\_\_, as our Attorney to do in our name and our behalf all or any of the acts, deeds or things necessary or incidental to the RfP for the Project \_\_\_\_\_ (name of the Project), including signing and submission of the RfP response, participating in the meetings, responding to queries, submission of information or documents and generally to represent us in all the dealings with Client or any other Government Agency or any person, in connection with the works, including signing of all Agreements with \_\_\_\_\_ (Client) in relation to the said RFP and thereafter till the expiry of the Agreement.

We hereby agree to ratify all acts, deeds and things lawfully done by our said Attorney pursuant to this power of attorney and that all acts, deeds and things done by our aforesaid Attorney shall and shall always be deemed to have been done by us.

(Add in the case of a Consortium)

Our firm is a Member or Lead bidder of the Consortium of \_\_\_\_\_, \_\_\_\_\_ and \_\_\_\_\_.

Dated this the \_\_\_\_\_ day of \_\_\_\_\_ 2018

(Signature and Name of authorized signatory)

\_\_\_\_\_

(Signature and Name in block letters of all the remaining partners of the firm Signatory for the Company)

Seal of firm Company

Witness 1:

Witness 2:

### **Note**

- *To be executed by all the members individually.*
- *Members can also submit Board Resolution*
- *The Mode of execution of the power of attorney should be in accordance with the procedure, down by the applicable law and the charter documents of the executant(s) and when it is so same should be under common seal affixed in accordance with the required procedure.*

**6.6 PQ Format 6 - Format for Power of Attorney for Lead Bidder**

[To be executed on non-judicial stamp paper of the appropriate value in accordance with relevant Stamp Act. The stamp paper to be in the name of the company who is issuing the power of attorney]

Whereas \_\_\_\_\_ has invited RfP response for \_\_\_\_\_ (Name of the Project)

Whereas, the Members of the Consortium comprising of M/s.\_\_\_\_\_, M/s.\_\_\_\_\_, M/s.\_\_\_\_\_ and M/s. \_\_\_\_\_ (the respective names and addresses of the registered offices to be given) are interested in bidding for the Project and implementing the same in accordance with the terms and conditions contained in the RfP Documents.

Whereas, it is necessary for the members of the Consortium to designate one of them as the lead member with all necessary power and authority to do, for and on behalf of the Consortium/Joint Venture, all acts, deeds and things as may be necessary in connection with the Consortium's/Joint Venture's RfP response for the Project.

NOW THIS POWER OF ATTORNEY WITNESSETH THAT

We, M/s.\_\_\_\_\_ and M/s \_\_\_\_\_ and M/s\_\_\_\_\_ hereby designate M/s. \_\_\_\_\_

being one of the members of the Consortium, as the lead member of the Consortium, to do on behalf of the Consortium, all or any of the acts, deeds or things necessary or incidental to the Consortium's RfP response for the Project, including submission of the RfP response, participating in meetings, responding to queries, submission of information or documents and generally to represent the Consortium in all its dealings with Client or any other Government Agency or any person, in connection with the Project until culmination of the process of bidding till the Project Agreement is entered into with Client and thereafter till the expiry of the Agreement.

We hereby agree to ratify all acts, deeds and things lawfully done by our said Attorney pursuant to this power of attorney and that all acts, deeds and things done by our aforesaid Attorney shall and shall always be deemed to have been done by us or Consortium/Joint Venture.

Dated this the \_\_\_\_\_ day of \_\_\_\_\_ 2018

\_\_\_\_\_

(Signature)

\_\_\_\_\_

(Name in Block Letter of Executant) [Seal of Company]

Witness 1

Witness 2

**Note**

*To be executed by all the members individually, in case of a Consortium/Joint Venture. The Mode of the power of attorney should be in accordance with the procedure, if any laid down by the applicable charter documents of the executant(s) and when it is so required the same should be under common in accordance with the required procedure.*

## **6.7 PQ Format 7 - Certificate of Non-Blacklisting**

**[To Be Furnished on the Letterhead of the Bidder/OEM]**

To

Managing Director,  
Kerala State Information Technology Infrastructure Ltd., TC No.: 14/196/2, 3rd Floor,  
Chandrasekharan Nair Stadium,  
Palayam, Trivandrum - 695033

**Subject:** RfP for Selection of an Agency for Implementation of Kerala Fibre Optic Network and Reliable Communication & Data Acquisition Network

**Ref:** Tender No: **KSITIL/MD/KFON/18/1852: 14/06/2018**

Sir/ Madam,

We confirm that our company, \_\_\_\_\_, is currently not blacklisted in any manner whatsoever by any of the State or UT and or Central Government in India on any ground including but not limited to indulgence in corrupt practice, fraudulent practice, coercive practice, undesirable practice or restrictive practice.

Signature:

**Name & Title of the Signatory:**

**Name & Address of the Entity:**

**Place:**

**Date:**

**Seal:**

**Note:**

1. *To be submitted by each of the Consortium members, in case of a consortium*

## **6.8 PQ Format 8 - Self-Declaration**

### **[To Be Furnished on the Letterhead of the Bidder]**

I \_\_\_\_\_ hereby declare that I am not in any way related to any KFON Ltd.'s, KSITIL's and KSEBL's employees who is in charge of or having control of this purchase. I agree that if, at any stage, it is found that this deed of declaration is untrue, the earnest money/security deposit paid by me will be forfeited and the contract entered will stand canceled.

It is understood that the relationship with the KFON Ltd.'s, KSITIL's and KSEBL's employee referred to herein will be restricted to my Father, Mother, Son, Daughter, Brother, Sister, Direct Uncle, Nephew, Father-in-law, Mother-in-law, Brother-in-law, Sister-in-law and First Cousins of the Officer concerned.

**Name & Title of the Signatory:**

**Name & Address of the Bidding Entity:**

**Place:**

**Date:**

**Seal:**

**Note:** - Bidders (all members of consortium) shall submit a declaration in the format prescribed below. Bidders are not having any connection directly or indirectly, with the concerned Authority, KSITIL or KSEBL e

## 6.9 PQ Format 9 - Non-Disclosure Agreement

WHEREAS, we the undersigned Bidder, \_\_\_\_\_, having our principal place of business or registered office at \_\_\_\_\_, are desirous of bidding for RfP No. <<>> dated << >> “Request for Proposal for Selection of an Agency for Implementation of Kerala Fibre Optic Network and Reliable Communication & Data Acquisition Network” (hereinafter called the said 'RfP') to the “Kerala Fibre Optic Network Ltd.”, hereinafter referred to as ‘Authority’.

And,

WHEREAS, the Bidder is aware and confirms that the Authority’s business or operations, information, application or software, hardware, business data, architecture schematics, designs, storage media and other information or documents made available by the Authority in the RfP documents during the bidding process and thereafter, or otherwise (confidential information for short) is privileged and strictly confidential and or proprietary to the Authority, NOW THEREFORE, in consideration of disclosure of confidential information, and in order to ensure the Authority’s grant to the Bidder of specific access to Authority’s confidential information, property, information systems, network, databases and other data, the Bidder agrees to all of the following conditions.

It is hereby agreed as under:

1. The confidential information to be disclosed by the Authority under this Agreement (“Confidential Information”) shall include without limitation, any and all information in written, representational, electronic, verbal or other form relating directly or indirectly to processes, methodologies, algorithms, risk matrices, thresholds, parameters, reports, deliverables, work products, specifications, architecture, project information, security or zoning strategies & policies, related computer programs, systems, trend analysis, risk plans, strategies and information communicated or obtained through meetings, documents, correspondence or inspection of tangible items, facilities or inspection at any site to which access is permitted by the Authority.
2. Confidential Information does not include information which:
  - a. the Bidder knew or had in its possession, prior to disclosure, without limitation on its confidentiality;
  - b. information in the public domain as a matter of law;
  - c. is obtained by the Bidder from a third party without any obligation of confidentiality;
  - d. the Bidder is required to disclose by order of a competent court or regulatory authority;
  - e. Is released from confidentiality with the written consent of the Authority.

The Bidder shall have the burden of proving hereinabove are applicable to the information in the possession of the Bidder.

3. The Bidder agrees to hold in trust any Confidential Information received by the Bidder, as part of the Tendering process or otherwise, and the Bidder shall maintain strict confidentiality in respect of such Confidential Information, and in no event a degree of confidentiality less than the Bidder uses to protect its own confidential and proprietary information. The Bidder also agrees:
  - a. to maintain and use the Confidential Information only for the purposes of bidding for this RfP and thereafter only as expressly permitted herein;
  - b. to only make copies as specifically authorized by the prior written consent of the Authority
  - c. and with the same confidential or proprietary notices as may be printed or displayed on the original;
  - d. to restrict access and disclosure of Confidential Information to their employees, agents, consortium members and representatives strictly on a "need to know" basis, to maintain confidentiality of the Confidential Information disclosed to them in accordance with this clause; and
  - e. To treat Confidential Information as confidential unless and until Authority expressly notifies the Bidder of release of its obligations in relation to the said Confidential Information.
4. Notwithstanding the foregoing, the Bidder acknowledges that the nature of activities to be performed as part of the Tendering process or thereafter may require the Bidder’s personnel to be present on premises of the Authority or may require the Bidder’s personnel to have access to software, hardware, computer networks, databases, documents and storage media of the Authority while on or off premises of the Authority. It is understood that it would be impractical for the Authority to monitor all information made available to the Bidder’s personnel under such circumstances and to provide notice to the Bidder of the confidentiality of all such information.

Therefore, the Bidder shall disclose or allow access to the Confidential Information only to those personnel of the Bidder who need to know it for the proper performance of their duties in relation to this project, and then only to the extent reasonably necessary. The Bidder will take appropriate steps to ensure that all personnel to whom access to the Confidential Information is given are aware of the Bidder's confidentiality obligation. Further, the Bidder shall procure that all personnel of the Bidder are bound by confidentiality obligation in relation to all proprietary and Confidential Information received by them which is no less onerous than the confidentiality obligation under this agreement.

5. The Bidder shall establish and maintain appropriate security measures to provide for the safe custody of the Confidential Information and to prevent unauthorized access to it
6. The Bidder agrees that upon termination or expiry of this Agreement or at any time during its currency, at the request of the Authority, the Bidder shall promptly deliver to the Authority the Confidential Information and copies thereof in its possession or under its direct or indirect control, and shall destroy all memoranda, notes and other writings prepared by the Bidder or its Affiliates or directors, officers, employees or advisors based on the Confidential Information and promptly certify such destruction.
7. Confidential Information shall at all times remain the sole and exclusive property of the Authority. Upon completion of the Tendering process and or termination of the contract or at any time during its currency, at the request of the Authority, the Bidder shall promptly deliver to the Authority the Confidential Information and copies thereof in its possession or under its direct or indirect control, and shall destroy all memoranda, notes and other writings prepared by the Bidder or its Affiliates or directors, officers, employees or advisors based on the Confidential Information within a period of sixty days from the date of receipt of notice, or destroyed, if incapable of return. The destruction shall be witnessed and so recorded, in writing, by an authorized representative of the Authority. Without prejudice to the above the Bidder shall promptly certify to the Authority, due and complete destruction and return. Nothing contained herein shall in any manner impair rights of the Authority in respect of the Confidential Information.
8. In the event that the Bidder hereto becomes legally compelled to disclose any Confidential Information, the Bidder shall give sufficient notice and render best effort assistance to the Authority to enable the Authority to prevent or minimize to the extent possible, such disclosure. Bidder shall not disclose to a third party any Confidential Information or the contents of this RfP without the prior written consent of the Authority. The obligations of this Clause shall be satisfied by handling Confidential Information with the same degree of care, which the Bidder applies to its own similar Confidential Information but in no event less than reasonable care.

For and on behalf of:

(BIDDER)

Authorized Signatory Office Seal:

Name:

Place:

Designation:

Date :



## 7 Technical Bid Formats

### 7.1 Tech Format 1 -Technical Bid Checklist

#	Documents to be submitted	Submitted (Y / N)	Documentary Proof
1.	Tech Format 2 – Tech Bid Covering letter		
2.	Tech Format 3 – Project Citations Details		
3.	Tech Format 4 – Approach & Methodology		
4.	Tech Format 5 – Work Plan & Staffing Schedule		
5.	Tech Format 6 – CV		
6.	Unpriced BoQ for Package A		
7.	Unpriced BoQ for Package B		
8.	Tech Format 7 – Summary & Detailed Compliance Sheets		
9.	Tech Format 8 – MAF for active and passive		
10.	Tech Format 9 – Details of Cable Manufacturer		
11.	Tech Format 10 – Statement of Deviations		

*Table 14: Technical Bid Checklist*

## 7.2 Tech Format 2 - Technical Bid Cover Letter

[To Be Furnished on the Letterhead of the Lead Bidder]

To

Managing Director,  
Kerala State Information Technology Infrastructure Ltd., TC No.: 14/196/2, 3rd Floor,  
Chandrasekharan Nair Stadium,  
Palayam, Trivandrum - 695033

**Subject** RFP for Selection of an Agency for Implementation of Kerala Fibre Optic Network and Reliable Communication & Data Acquisition Network

**Ref** Tender No: **KSITIL/MD/KFON/18/1852: 14/06/2018**

Sir/ Madam,

We, the undersigned, offer to provide our services in accordance with scope outlined in your Request for Proposals (RfP) dated ..... and our Proposal. "We are hereby submitting our Proposal, which includes this Technical Proposal and a Financial Proposal in separate envelope"

We hereby declare that:

- a) All the information and statements made in this Proposal are true and we accept that any misinterpretation or misrepresentation contained in this Proposal may lead to our disqualification by the Client and/or may be sanctioned by the Bank.
- b) Our Proposal shall be valid and remain binding upon us for the period of contract.
- c) We have no conflict of interest in implementation of this project and we meet the eligibility requirements as stated in RfP.
- d) We, along with any of our sub-consultants, sub-contractors, suppliers, or service providers for any part of the contract, are not subject to, and not controlled by any entity or individual that is subject to, a temporary suspension or a debarment imposed by any state government or central government entity;
- e) In competing for (and, if the award is made to us, in executing) the Contract, we undertake to observe the laws against fraud and corruption, including bribery, in force in the country.
- f) We undertake to negotiate a Contract on the basis of the proposed core team. We accept that the substitution of core team members for reasons other than those approved by client may lead to the termination of Contract negotiations.
- g) Our Proposal is binding upon us and subject to any modifications resulting from the Contract negotiations.

We undertake, if our Proposal is accepted and the Contract is signed, to initiate the Services related to the assignment no later than one (1) week upon signing of contract.

We understand that the Authority is not bound to accept any Proposal that the Authority receives.

We remain,

Yours sincerely,

**Volume- I**

---

Signature:

**Name & Title of the Signatory:**

**Name & Address of the Entity:**

**Place:**

**Date:**

**Seal:**

### 7.3 Tech Format 3 - Project Citations Summary & Details for Package Summary of Credentials

Sl. No.	Project Name	Client Name	Client Type	Role on the project	Project Value (in INR)	Project Component	Project Status (Complete Ongoing/ Withheld)	Documentary Evidence provided (Yes or No)

Table 15: Project Citations

The above format shall be supplemented with detailed project citations in the format provided below.

#### Detailed citation format

<b>Name of the Project</b>	
<b>General Information</b>	
Client for which the project was executed	
Name and contact details of the client	
<b>Project Details</b>	
Description of the project	
Scope of work of the Bidder	
Deliverables of the Bidder	
Technologies used	
Outcomes of the project	
<b>Other Details</b>	
Total cost of the project	
Total cost of the services provided by the Bidder	
Duration of the project (no. of months, start date, completion date, current status)	
<b>Other Relevant Information</b>	
Mandatory Supporting Documents:	
Work order / Purchase order / Contract for the project	
Client Certificate giving present status of the project	

Table 16: Format for project citation

## 7.4 Tech Format 4 - Approach & Methodology

1.	Understanding of scope and objectives (Max 3 Pages) <i>(Do not repeat/copy from RFP, give your own understanding basis the TOR)</i>	<ul style="list-style-type: none"> <li>• Explain short term and long term objectives</li> <li>• Users and Usage</li> <li>• Future potential</li> <li>• Task involved under the project</li> <li>• Phasing and coverage</li> <li>• Challenges envisaged and solution proposed</li> <li>• Stakeholders and role</li> </ul>
2.	Fibre Commissioning Methodology (Max 10 Pages)	Use industry standard practices and acceptable protocols – Cite examples where delivered using similar approach and share the experience and outcomes.
3.	Testing and QA (Max 5 Pages)	<ul style="list-style-type: none"> <li>• Identify KPIs to meet project objectives in terms of capacity, availability, QoS, performance, Service levels, manageability etc.</li> <li>• Explain how proposed methodology will record and present the test parameters.</li> <li>• Explain mechanism to deal with sub-optimal test results, as an exception, on identified KPIs.</li> <li>• Explain your QA methods to ensure adherence to Industry standards and acceptable performance benchmarks.</li> </ul>
4.	Solution compliance to functional/technical requirements	List the functional/technical requirements and provide solution compliance in the format provided in this Tender. Bidders are required to OEM data sheets/brochures
5.	Scalability plan for 20 Years (Max 2 Pages)	<ul style="list-style-type: none"> <li>• Projected user base and usage network</li> <li>• How easily and cost effectively the solution can scale up to meet increased demand resulting from new users/usage/services</li> <li>• Assurance of support and life of technology proposed</li> </ul>
6.	Manageability of network, users, usage (Max 2 Pages)	Discuss the complexities involved in managing the user and usage in catering to dynamic and heterogeneous demand, how the proposed solution navigates this complexity. O&M approach post commissioning – How the proposed team and practices will manage the network and user demand seamlessly. Proactive measures to identify issues and provide solution to avoid the same.
7.	Assured Availability of Services (Max 2 Pages)	Explain portfolio of users and services envisaged. Outline levels of services expected now/future. How does the solution ensure availability of services to respective user segments? Discuss ease of solution in accepting new services and catering to higher service levels. Discuss possible failure scenarios and the ability of solution to overcome the scenario.
8.	Performance (Max 2 Pages)	How the solution assures desired QoS? What are the features that helps assure performance against the user demand? Robustness against high demand / load. Performance monitoring and optimization options available.
9.	Enhanceability of Features & Functions (Max 2 Pages)	How well/ easily the solution can be enhanced to add new features and technology in keeping with project objectives. How well/ easily the solution can be integrated with external systems to add new features and technology in keeping with project objectives.
10.	Project Management Approach (Max 3 Pages)	<ul style="list-style-type: none"> <li>• Staffing</li> <li>• Equipment</li> <li>• Planning</li> <li>• Monitoring</li> </ul>

		<ul style="list-style-type: none"> <li>• Reporting</li> <li>• Decision Making</li> <li>• Governance</li> </ul> <p>How to avoid cost and time overruns? How to overcome external dependencies?</p>						
11.	Risk Identified and Mitigation Proposed (Max 2 Pages)	<table border="1"> <thead> <tr> <th><b>Risk Identified</b></th> <th><b>Mitigation planned &amp; proposed</b></th> </tr> </thead> <tbody> <tr> <td></td> <td></td> </tr> <tr> <td></td> <td></td> </tr> </tbody> </table>	<b>Risk Identified</b>	<b>Mitigation planned &amp; proposed</b>				
<b>Risk Identified</b>	<b>Mitigation planned &amp; proposed</b>							
12.	Comments on the Term of Reference (Max 1 Page)	Comments and suggestions on the Terms of Reference that could improve the quality/effectiveness of the assignment						

*Table 17: Approach & Methodology*

## **7.5 Tech Format 5 - Work Plan and Staffing Plan**

### **Work Plan**

Please outline the plan for the implementation of the main activities/tasks of the project, their sub tasks and duration, phasing and interrelations, milestones (including interim approvals by the Client), and tentative completion dates of the milestones. The proposed work plan should be consistent with the technical approach and methodology, showing your understanding of the TOR and ability to translate them into a feasible working plan. A list of the final deliverables (including reports) to be delivered as final output(s) should be included here. The work plan should be consistent with the Work Schedule Form.

### **Organization and Staffing**

Please describe the structure and composition of your team for different scope components, including the list of the Core team, Field team and relevant technical and administrative support staff.

### **7.5.1 Personnel required for project execution**

SI shall independently estimate the teams and their size required to meet the requirements of project – both during the implementation period and to maintain Service Levels as specified as part of this tender. SI shall provide clear definition of the role and responsibility of each individual personnel. SI shall have a defined hierarchy and reporting structure for various teams that shall be part of the project. SI shall also provide the list of proposed Resources for the Project (onsite/offsite) for the entire contract period which shall be binding upon them. Any changes in resource deployment will have to be approved by the Authority.

The SI will increase the strength if it is required by the Authority to do so. SI shall be required to provide manpower meeting following requirements:

- SI shall assign a Project Director (from the higher management team of the SI's organization) to make commitments and decisions that are binding on the SI. Project Director shall be present for all Steering Committee meetings, monthly review meetings and any meeting chaired by the Secretaries of the concerned department.
- SI shall also deploy a Project Manager who shall be onsite full time throughout the contract period for regular co-ordination and monitoring of the project. The Authority will constitute a PMU to coordinate all the project activities on behalf of Authority. All correspondence and communications between the Authority and the SI shall be coordinated through the Project Manager and PMU.
- SI shall propose the Core team consisting of experts from different domains like – passive infrastructure, quality assurance, network/telecom, systems integration etc.
- SI shall deploy adequate number of parallel teams on ground for undertaking field activities such as survey, laying of fibre, setting up of PoPs, testing at field etc. to implement the network. As the timelines for commissioning entire network is 24 months, it is imperative to have parallel teams working in different milestones for timely completion of work and adherence to SLAs. Authority will expect the SI to submit separate work plans and staffing schedule by optimally dividing the entire scope. The work progress in each milestone shall be monitored against the respective work plans.
- Site Managers may be engaged by the SI to report to the Project Manager, in order to ensure that the correct information is communicated from the commencement of the project until the hand-over of the network to the client.
- SI may propose the personnel required to manage the NOC including Manager, technical specialists in the areas of Security, Network, Storage, EMS/NMS, Database, BMS, Physical infrastructure, etc, Helpdesk operators and Physical security
- SI shall work out the model to estimate the required field staff to maintain this state wide optical fibre network including active, passive elements and associated services like Internet and Intranet services. SI has to estimate the exact number of personnel to maintain the SLA requirement mentioned in this Tender. SI shall also work out the other resources required for maintenance of the network and get it pre-approved from Authority.
- Operational manpower shall work in shifts, with no person being made to see the feeds for more than 8 hours at a stretch.
- SI shall submit the CVs (with full details on qualification, experience) of the proposed manpower to be deployed for this project (both for implementation and O&M periods) along with their roles and responsibilities.
- System Integrator shall have to replace any person, if Authority finds not suitable for the job.
- SI shall prepare the detailed operational guideline document during implementation which shall specify detail responsibilities of these resources and their do's & don'ts



**7.5.2 Work Schedule and planning**

Sl. No.	Tasks	Months											TOTAL	
		1	2	3	4	5	6	7	8	9	....	n		
<b>T-1</b>	Task 1													
	Sub task 1													
	Sub task 2													
	Sub task n													
<b>T-2</b>	Task 2													
	Sub task 1													
	Sub task n													
<b>T-3</b>	Task 3													
	Sub task 1													
	Sub task n													

*Table 18: Work Schedule & planning*

**Note:**

1. List the Tasks with the breakdown for activities required to produce them and other benchmarks such as the Client’s approvals. For phased assignments, indicate the activities, delivery of goods/services/reports, and benchmarks separately for each phase.
2. Duration of activities shall be indicated in a form of a bar chart.
3. Include a legend, if necessary, to help read the chart.

### 7.5.3 Staffing Schedule

Enter man-month effort against each task mentioned in the work plan. No. of resources mentioned are minimum. Bidder shall do his own assessment of the manpower requirement and may

	Sl. No.	Resource	Onsite/Offsite	No. of Resources	Resources input per task				Total input (in months)
					month	per	each	task	
					T1	T2	...	Tn	
Implementation Period	1								
	2								
	..								
	N								
O&M period	1								
	2								
	..								
	N								

Table 19: Staffing Schedule

### 7.6 Tech Format 6 - CV

<b>1</b>	<b>Name of the Staff</b>				
<b>2</b>	<b>Current Designation in the Organization</b>				
<b>3</b>	<b>Proposed Role in the Project</b>				
<b>4</b>	<b>Proposed Responsibilities in the Project</b>				
<b>5</b>	<b>Date of Birth</b>				
<b>6</b>	<b>Education</b>	<ul style="list-style-type: none"> <li>•Degree / Diploma, College, University, Year of Passing</li> <li>•Degree / Diploma, College, University, Year of Passing</li> </ul>			
<b>7</b>	<b>Summary of Key Training and Certifications</b>				
<b>8</b>	<b>Countries of Work Experience</b>				
<b>9</b>	<b>Language Proficiency</b>	Language	Reading	Writing	Speaking

<b>10</b>	<b>Employment Record (For the total relevant experience)</b>				
		From / To:			
		Employer:			
		Position Held:			
		From / To:			
		Employer:			
		Position Held:			
		From / To:			
		Employer:			
<b>11</b>	<b>Total No. of Years of Work Experience</b>				
<b>12</b>	<b>Total No. of Years of Experience for the Role proposed</b>				
<b>13</b>	<b>Detailed Tasks Assigned on Experts {List all deliverables/tasks which the Expert will be involved)</b>				
	<b>Reference to Prior Work/Assignments that Best Illustrates Capability to Handle the Assigned Tasks :</b>				
	<b>Year:</b>				
	<b>Location:</b>				
	<b>Client:</b>				
	<b>Main project features:</b>				
	<b>Positions held:</b>				
<b>Activities performed:</b>					
<b>14</b>	<b>Contact Information</b>	Email:			
		Contact number:			

*Table 20: Format for CV*

**Certification:**

**Volume- I**

---

I, the undersigned, certify that to the best of my knowledge and belief, this CV correctly describes myself, my qualifications, and my experience, and I am available, as and when necessary, to undertake the assignment in case of an award. I understand that any misstatement or misrepresentation described herein may lead to my disqualification or dismissal by the Client, and/or sanctions by the Bank.

---

Name of Expert

Signature

Date

---

Name of the authorized signatory

Signature

Date

## 7.7 Tech Format7 - Summary & Detailed Sheets of Compliance to the Benchmarks/Minimum Specifications

Bidder is required to submit compliance to the required benchmark / minimum specifications for various IT / Non-IT components. This compliance would be needed in two formats –

1. Summary table given below for all the items
2. Compliance tables for each of the line item against the benchmark specifications specified in the Tender (Volume II)
3. Bidder should refer Volume II of the Tender for details on the functional requirements of the system and the benchmark specifications for the items procured under this tender

### 1) Summary Table of the Compliance of Requirements

#	Component	Description	OEM	Make & Model	Page No. of Datasheet/ OEM Brochure/Manual attached	Compliance to Required Specifications? (Yes / No)
1.	.....					
2.	.....					
3.	.....					

Table 21: Summary compliance table

### 2) Detailed compliance tables for each of the above mentioned line items against benchmark specifications specified in the Tender (Volume II)

Name of the Equipment:

Make & Model:

#	Minimum Specification / Requirement mentioned in Tender	Page No. of Datasheet/ OEM Brochure/Manual attached	Compliance (Yes / No)	Remarks (If compliance is No)
1.				
2.				
3.				

Table 22: Detailed compliance sheet

## 7.8 Tech Format 8 - Manufacturer Authorization OEMs

[To Be Furnished on the Letterhead of the OEM]

To

Managing Director,  
Kerala State Information Technology Infrastructure Ltd., TC No.: 14/196/2, 3rd Floor,  
Chandrasekharan Nair Stadium,  
Palayam, Trivandrum - 695033

**Subject:** RFP for Selection of an Agency for Implementation of Kerala Fibre Optic Network and Reliable Communication & Data Acquisition Network

**Ref:** Tender No: **KSITIL/MD/KFON/18/1852: 14/06/2018**

Sir,

We \_\_\_\_\_, (name and address of the manufacturer) who are established and reputed manufacturers of \_\_\_\_\_ having factories at \_\_\_\_\_ (addresses of manufacturing / development locations) do hereby authorize M/s \_\_\_\_\_ (name and address of the Bidder) to bid, negotiate and conclude the contract with you against the above mentioned tender for the above equipment / software manufactured / developed by us.

We herewith certify that the above mentioned equipment / software products are not end of the life and we hereby undertake to support these equipment / software for the duration of minimum five years from the date of commissioning

Yours faithfully,

For and on behalf of M/s \_\_\_\_\_ (Name of the manufacturer)

Signature:

**Name & Title of the Signatory:**

**Name & Address of the Entity:**

**Place:**

**Date:**

**Seal:**

**Note:**

- 1. This letter of authority should be on the letterhead of the concerned manufacturer and should be signed by an authorized signatory of the manufacturer. The same would need to be submitted by the Bidder along with the Bid of Technical Bid.*
- 2. For Fibre & accessories, a performance warranty for 25 years shall be submitted.*

**7.9 Tech Format 9 - Details of Cable Manufacturer/Supplier****[To Be Furnished on the Letterhead of the Cable Manufacturer]**

The information furnished / the replies to the questionnaire should be complete in all respects. In case the information or the reply is “NIL OR NOT APPLICABLE” etc., it should be mentioned accordingly.

<b>Sl. No.</b>	<b>Question</b>	<b>Response</b>
1.	Name of the Firm	
2.	Nationality of the Firm	
3.	Head Office Address, email-id, contact no.	
4.	Former name of the company(if any)	
5.	List of Branch offices	
6.	Type of Company (individual/partnership/incorporated company)	
7.	Year of establishment and place	
8.	Whether the firm is a. Member of a group of Companies. (If yes, give name, address connections and descriptions of the other companies) b. Subsidiary of a large organization	
9.	Are you a manufacturer/Supplier of the product	
10.	Guarantee offered for OPGW/ADSS/UG cable	
11.	Are you registered with any Government Dept./Public Sector Undertaking(if yes give details)	
12.	How many years has your organization been in business under the present business name?	
13.	Name & address of the affiliate, subsidiary partnership, joint venture and parent companies(include nature of the firm and present engagement)	
14.	Name of any international organization for which your firm has already been registered/prequalified	
15.	Indicate ISO certification, if any	
16.	What is the maximum value of supply that your firm can handle?	

*Table 23: Details of Cable Manufacturer*

Signature:

**Name & Title of the Signatory:****Name & Address of the Entity:****Place:****Date:****Seal:**

## 7.10 Tech Format 10 - Statement of Deviation

[To Be Furnished on the Letterhead of the Lead Bidder]

### “STATEMENT OF DEVIATIONS”

**Name of Work** - for Selection of an Agency for Implementation of Kerala Fibre Optic Network and Reliable Communication & Data Acquisition Network

**Ref Tender No:** **KSITIL/MD/KFON/18/1852: 14/06/2018**

Bidders Name and Address:

To

Managing Director,  
Kerala State Information Technology Infrastructure Ltd., TC No.: 14/196/2, 3rd Floor,  
Chandrasekharan Nair Stadium,  
Palayam, Trivandrum - 695033

Dear Sir,

Sub:-Deviations from bid conditions relating to Tender Ref **KSITIL/MD/KFON/18/1852: 14/06/2018**

In respect of whatever has been stated to the contrary anywhere else in our offer, only the following are the deviations and variations from the exception to the specifications and documents for the subject Tender Ref **KSITIL/MD/KFON/18/1852: 14/06/2018**. These deviations and variations are exhaustive, except these deviations. The entire supply will be effected as per your bid specifications and documents. Further I/We agree that additional conditions, if any, found in the offer other than those stated below, except those pertaining to any rebates offered/reductions in cost to the Client shall not be given effect to. I/we also certify that the financial implication of these deviations if to be withdrawn has also been furnished.

Signature:

**Name & Title of the Signatory:**

**Name & Address of the Entity:**

**Place:**

**Date:**

**Seal:**



### 7.10. Deviation to Technical Specification

Sl. No.	Complete description of deviation	Ref. Pages No. Clause & P of Tender documents	Monetary implication of the condition in case of total withdrawal	
			INR in figures	INR in words

Table 24: Deviation to technical specification

**Note** Here, the bidder should indicate the amount of money, if any, which he would charge extra i.e., in addition to the rates quoted by him for withdrawal of his condition/deviation and accepting the condition as stipulated in bid documents. Full details as to how the monetary implication as above has been arrived at shall also be clearly stated.

Signature:

**Name & Title of the Signatory:**

**Name & Address of the Entity:**

**Place:**

**Date:**

**Seal:**

### 7.10. Deviation to Commercial Conditions

Sl. No.	Complete description of deviation	Ref. Pages No. Clause & P of Tender documents	Monetary implication of the condition in case of total withdrawal	
			INR in figures	INR in words

Table 25: Deviations to commercial condition

**Note** Here, the bidder should indicate the amount of money, if any, which he would charge extra i.e., in addition to the rates quoted by him for withdrawal of his condition/deviation and accepting the condition as stipulated in bid documents. Full details as to how the monetary implication as above has been arrived at shall also be clearly stated.

Signature:

**Name & Title of the Signatory:**

**Name & Address of the Entity:**

**Place:**

**Date:**

**Seal:**

## 8 Commercial Bid Formats

### 8.1 General Instructions

- a. Bidder should provide all prices as per the prescribed format under this Chapter.
- b. All the prices are to be entered in Indian Rupees (INR) only
- c. It is mandatory to provide breakup of all Taxes, Duties and Levies wherever asked for. The prices quoted shall indicate all freight and Insurance charges, duties and taxes etc. which may become payable by the SI under existing or further laws or rules of the country of origin or supply during the course of execution of the contract. In the absence of specific stipulation to the contrary in the bids, it will be assumed that the prices quoted are inclusive of all such taxes, duties unloading charges etc. Extra claims therefore will not be accepted. The ruling rates of taxes/duties as applicable shall be stated in Bid. Increase in the rate of taxes/duties, outside the contractual delivery period will be to the suppliers' account. In case payment of customs/excise duty is to be borne by consignee the duty will be paid on unloaded invoices price only in the first instance and difference being paid when the bidder produces the final assessment orders later.
- d. Authority, reserves the right to ask the Bidder to submit proof of payment against any of the taxes, duties, levies indicated.
- e. The Bidder needs to account for all Out of Pocket expenses due to Boarding, Lodging and other related items.
- f. The Unit Rate as mentioned in the following formats may be used for the purpose of 'Change Order' for respective items, if any. However, based on the market trends, Authority, retains the right to negotiate this rate for future requirement
- g. Bidder shall be bound to give same or more % of discount on the list price of the OEMs on the future purchases (additional purchases within the contract period) by Authority. Bidder shall ensure that the future products supplied are of latest specifications as per the OEM roadmap.
- h. For the purpose of evaluation of Commercial Bids, Authority shall make appropriate assumptions to arrive at a common Bid price for all the bidders. This however shall have no co-relation with the Contract value or actual payment to be made to the Bidder.
- i. Authority also intends to utilize various rates obtained through this tender for requirements across various departments. Bidders are requested to factor this larger demand and give the best possible rate to Authority
- j. No escalations of prices will be considered under any circumstances.

## 8.2 Commercial Bid Letter

**[To Be Furnished on the Letterhead of the Lead Bidder]**

To

Managing Director,  
Kerala State Information Technology Infrastructure Ltd., TC No.: 14/196/2, 3rd Floor,  
Chandrasekharan Nair Stadium,  
Palayam, Trivandrum - 695033

**Subject** Request for Proposal for Selection of an Agency for Implementation of Kerala Fibre Optic Network and Reliable Communication & Data Acquisition Network

**Ref** Tender No: **KSITIL/MD/KFON/18/1852: 14/06/2018**

We, the undersigned Bidder, having read and examined in detail all the Tender Documents in respect of Request for Proposal for Selection of an Agency for Implementation of Kerala Fibre Optic Network and Reliable Communication & Data Acquisition Network do hereby propose to provide services as specified in the Tender Documents number **KSITIL/MD/KFON/18/1852: 14/06/2018**

### 1. PRICE AND VALIDITY

- All the prices mentioned in our Tender are in accordance with the terms as specified in the Tender Documents. All the prices and other terms and conditions of this Tender are valid for a period of 180 calendar days from the date of opening of the Tenders.
- We hereby confirm that our Tender prices include all taxes. Taxes are quoted separately under relevant sections, as specified in the Tender formats.
- We have studied the clause relating to Indian Income Tax and hereby declare that if any income tax, surcharge on Income Tax, Professional and any other corporate Tax in altered under the law, we shall pay the same.

### 2. UNIT RATES

We have indicated in the relevant schedules enclosed, the unit rates for the purpose of on account of payment as well as for price adjustment in case of any increase to / decrease from the scope of work under the contract.

### 3. QUALIFYING DATA

We confirm having submitted the information as required by you in your Instruction to Bidder. In case you require any other further information/documentary proof in this regard before evaluation of our Tender, we agree to furnish the same in time to your satisfaction.

### 4. BID PRICE

We declare that our Bid Price is for the entire scope of the work as specified in the Tender Documents. These prices are indicated in the subsequent sub-sections of this Section.

### 5. CONTRACT PERFORMANCE SECURITY

We hereby declare that in case the contract is awarded to us, we shall submit the contract Performance Security in the form prescribed in the Tender.

## **Volume- I**

---

We hereby declare that our Tender is made in good faith, without collusion or fraud and the information contained in the Tender is true and correct to the best of our knowledge and belief.

We understand that our Tender is binding on us and that you are not bound to accept a Tender you receive. We confirm that no technical deviations are attached here with this Commercial Bid.

Thanking you,

Yours faithfully,

Signature:

**Name & Title of the Signatory:**

**Name & Address of the Entity:**

**Place:**

**Date:**

**Seal:**

**8.3 BoQ for Package A** \*(to be filled in the excel provided)

#	Item	UoM	Total Qty	Unit price	Total price without tax	Tax rate
1	2	3	4	5	6 = (5) (4)	7
<b>FIBER &amp; ACCESSORIES</b>						
<b>A. OPGW Cable &amp; Accessories</b>						
1	48F DWSM OPGW fiber optic cable	Km	516			
2	Installation hardware set for the above 48F OPGW fiber optic cable including all cable fittings, accessories	Set	516			
3	Joint Box	Nos	259			
<b>B Installation, Commissioning &amp; Testing for OPGW Installation</b>						
1	Survey of route, design and submission of drawing for approval and detailed list of materials required for the work and providing as built drawing after the execution of work.	Km	516			
2	Installation of 48 Fiber (DWSM) OPGW optic fiber cable on transmission tower, fixing of hardware set, cable fittings and accessories and installation of joint boxes and its terminations etc.	Km	516			
3	Splicing and installation of Joint Boxes	Set	259			
4	End to End testing of OPGW and approach cable and accessories	Km	516			
<b>C. OF Cable &amp; Accessories</b>						
1	48F ADSS fiber optic cable with 100 Kmph	Km	14,886			
2	48F ADSS fiber optic cable with 150 Kmph	Km	10,097			
3	24F ADSS fiber optic cable	Km	10,250			
4	12F ADSS fiber optic cable	Km	7,409			
5	Anchoring / tensioning clamp assembly for the poles	No	639,630			
6	Suspension clamp assembly	No	426,420			
7	Adjustable Cable Storage Bracket	No	170,568			

**Volume- I**

#	Item	UoM	Total Qty	Unit price	Total price without tax	Tax rate
1	2	3	4	5	6 = (5) (4)	7
8	Down Lead Clamps Assembly	No	170,568			
9	48F UG fiber optic cable	Km	600			
10	PLB HDPE pipe	Km	600			
11	RCC route indicators	No.	3,000			
12	Man holes	No.	300			
13	4F fiber optic drop cable	Km	6,088			
14	Anchoring / tensioning clamp assembly for the poles	No	91,320			
15	Suspension clamp assembly	No	60,880			
16	Adjustable Cable Storage Bracket	No	24,352			
17	Down Lead Clamps Assembly	No	24,352			
18	Anchoring bolt	No	30,438			
19	Street Box Type I - (Branch Joint Closure)	No.	29,241			
20	Street Box Type II - (FTB Type II)	No.	6,088			
21	FTB Type I at end office	No.	30,438			
22	1:4 optical splitter	No.	13,049			
23	1:8 optical splitter	No.	2,039			
24	Poles and accessories	No	5,000			
<b>D. Installation, Commissioning &amp; Testing for OFC &amp; accessories</b>						
1	Survey of route, design and submission of drawing for approval and detailed list of materials required for the work and providing as built drawing after the execution of work	Km	49,330			
2	Installation of 48FADSS optic fiber cable, fixing of hardware set, cable fittings, accessories, joint closures, FTB, splicing and terminations etc.	Km	24,983			

**Volume- I**

#	Item	UoM	Total Qty	Unit price	Total price without tax	Tax rate
1	2	3	4	5	6 = (5) (4)	7
3	Installation of 24FADSS optic fiber cable, fixing of hardware set, cable fittings, accessories, joint closures, FTB, splicing and terminations etc.	Km	10,250			
4	Installation of 12FADSS optic fiber cable, fixing of hardware set, cable fittings, accessories, joint closures, FTB, splicing and terminations etc.	Km	7,409			
5	Excavation of trench for PLB laying, PLB laying, back filling, reinstatement and compaction, laying of 48 F UG optical fiber cable, its splicing and terminations etc. and all other allied activities	Km	600			
6	Installation of 4FADSS optic fiber cable, fixing of hardware set, cable fittings, accessories, joint closures, FTB, splicing and terminations etc.	Km	6,088			
7	End to End testing of total OFC and accessories	Km	49,330			
8	Installation of Poles and accessories	Nos	5,000			
<b>Total CAPEX for Fibre &amp; Accessories</b>						
<b>IT &amp; NON - IT</b>						
<b>A. NOC-Non IT</b>						
1	Civil works including site preparation and partitioning works, false flooring, false ceiling, floor strengthening, etc.	Site	1			
2	Electrical works including light fixtures, cabling, panels + Earthing etc.	Site	1			
3	250 KVA DG set with AMF Panel and required foundation and civil structure	No.	2			
4	Precision AC for server room	Lot.	1			
5	Comfort AC for NOC, UPS, BMS, Meeting, electrical rooms, etc.	Lot.	1			
6	80 kVA online UPS (with SNMP) with 30 minutes battery backup and battery enclosure for server farm area	No.	2			



**Volume- I**

#	Item	UoM	Total Qty	Unit price	Total price without tax	Tax rate
1	2	3	4	5	6 = (5) (4)	7
7	30 kVA online UPS (with SNMP) with 30 minutes battery backup and battery enclosure for help desk and other areas	No.	2			
8	Access Control System (RFID + Biometric, smart cards) to manage NOC and all the PoP locations	Set	1			
9	High Sensitivity Smoke Detection System	Set	1			
10	Fire Detection System	Set	1			
11	Fire Suppression System	Set	1			
12	Indoor Dome Camera	Lot.	1			
13	Rodent Repellent System	Set	1			
14	Water Leak Detection System	Set	1			
15	Integrated Building Management Solution	Set	1			
16	42U Network Racks installed with redundant PDUs, Industrial sockets and accessories	No.	4			
17	42U Server Racks installed with redundant PDUs, Industrial sockets and accessories	No.	16			
18	LCD Projector	No.	1			
19	70" LED TV	No.	3			
20	Network Colour Laser Printer	No.	1			
21	Network MFP	No.	1			
22	Passive Items	Lot.	1			
23	Workstation Furniture and Fixtures including chairs	Set	20			
24	Conference Table (for 10 personnel) & Chairs	Set	1			
25	Public Addressable System	Set	1			
<b>B. NOC - IT components</b>						
1	IP MPLS Router	No.	2			
2	Internet router	No.	2			

**Volume- I**

#	Item	UoM	Total Qty	Unit price	Total price without tax	Tax rate
1	2	3	4	5	6 = (5) (4)	7
3	URL Filtering Firewall	No.	2			
4	DC Firewall	No.	2			
5	DC Core Switch	No.	2			
6	Access Switch	No.	4			
7	Aggregation Switch	No.	2			
8	SAN storage (80 TB) for application & DB	Set	1			
9	Video storage (200 TB)	Set	1			
10	SAN Switch	No.	2			
11	Secondary Storage	Set	1			
12	Blade Chassis	Set	1			
13	Servers	Lot.	1			
14	OS licenses	Lot.	1			
15	DB licenses	Lot.	1			
16	Virtualization software license	Lot.	1			
17	Workstation computers	No.	5			
18	Desktop Computers	No.	15			
19	IP phones	No.	20			
20	IP PBX	No.	2			
21	Voice Router	No.	2			
22	Video Management System base license	Lot.	1			
23	Video Management System camera license	No.	400			
24	Video wall display, Controller, Video wall Management Software & Accessories	Set	1			
25	Link load balancer	No.	2			
26	KVM switch (If Required)	No.	2			

**Volume- I**

#	Item	UoM	Total Qty	Unit price	Total price without tax	Tax rate
1	2	3	4	5	6 = (5) (4)	7
27	Backup and archival solution	Lot.	1			
28	EMS solution for Network(for MPLS & DWDM) with NMS	Lot.	1			
29	EMS solution for GPON with NMS	Lot.	1			
30	BSS software including CRM, Enterprise & Partner billing module, and self-care portal	Lot.	1			
31	Anti-virus software	Lot.	1			
32	GIS software license	Lot.	1			
33	Fibre Monitoring System	Lot.	1			
34	Centralized Access Control system software	Lot.	1			
35	Project Management Software	Lot.	1			
<b>C. Core PoP</b>						
1	Modular MPLS Router	No.	28			
2	24 port Access Switch	No.	14			
3	Desktop Computers	No.	14			
4	IP phones	No.	14			
5	High Density Fiber Distribution Frame	No.	14			
6	15 kVA UPS (with SNMP) with 30 minutes battery backup and battery enclosure	No.	28			
7	42U server racks installed with redundant PDUs, Industrial sockets and accessories	No.	28			
8	Split Air Conditioners 3 TR with timer	Nos	42			
9	Pre-fabricated Shelter	Set	14			
10	Indoor CCTV Dome Camera	No	14			
11	Indoor CAT 6 patch cord 10 mtr.	No.	28			

**Volume- I**

#	Item	UoM	Total Qty	Unit price	Total price without tax	Tax rate
1	2	3	4	5	6 = (5) (4)	7
12	Access Control system with Biometric + Smart card Reader & Smart Card, Push button, Magnetic lock and accessories	Set	14			
13	Fibre monitoring unit with minimum of 4 ports and scalable to 8 ports	No.	14			
14	Spare Cable Box	No.	14			
15	Passive Cabling & Accessories	Lot.	14			
16	Site Preparation( partition for UPS, exhaust fan, painting, light & fans) and Electrical works including earthing	site	14			

**D. Aggregation PoP**

1	Modular MPLS Router	No.	87			
2	24 port Access Switch	No.	87			
3	High Density Fiber Distribution Frame	No.	87			
4	5 kVA UPS (with SNMP) with 30minutes battery backup and battery enclosure	No.	174			
5	42U server Racks installed with redundant PDUs, Industrial sockets and accessories	No.	87			
6	Split Air Conditioners – 2 TR with timer	Nos	174			
7	Pre-fabricated Shelter	Set	87			
8	Indoor CCTV Dome Camera	No	87			
9	Indoor CAT 6 patch cord 10 mtr.	No.	174			
10	Access Control system with Biometric + Smart card Reader & Smart Card, Push button, Magnetic lock and accessories	Set	87			
11	Spare Cable Box	No.	87			
12	Passive Cabling & Accessories	Lot.	87			

**Volume- I**

#	Item	UoM	Total Qty	Unit price	Total price without tax	Tax rate
1	2	3	4	5	6 = (5) (4)	7
13	Site Preparation( partition for UPS, exhaust fan, painting, light & fans) and Electrical works including earthing	site	87			
<b>E. Pre- Aggregation PoP</b>						
1	IP MPLS Router	No.	194			
2	24 port Access Switch	No.	194			
3	High Density Fiber Distribution Frame	No.	194			
4	5 kVA UPS (with SNMP) with 30minutes battery backup and battery enclosure	No.	388			
5	42U server Racks installed with redundant PDUs, Industrial sockets and accessories	No.	194			
6	Split Air Conditioners – 2 TR with timer	No.	388			
7	Pre-fabricated Shelter	Set	194			
8	Indoor CCTV Dome Camera	No.	194			
9	Indoor CAT 6 patch cord 10 mtr.	No.	388			
10	Access Control system with Biometric + Smart card Reader & Smart Card, Push button, Magnetic lock and accessories	Set	194			
11	Spare Cable Box	No.	194			
12	Passive Cabling & Accessories	Lot.	194			
13	Site Preparation( partition for UPS, exhaust fan, painting, light & fans) and Electrical works including earthing	site	194			
<b>F. Spur PoP</b>						
1	IP MPLS Router	No.	83			
2	24 port Access Switch	No.	83			
3	High Density Fiber Distribution Frame	No.	83			

**Volume- I**

#	Item	UoM	Total Qty	Unit price	Total price without tax	Tax rate
1	2	3	4	5	6 = (5) (4)	7
4	3 kVA UPS (with SNMP) with 30minutes battery backup and battery enclosure	No.	166			
5	42U server Racks installed with redundant PDUs, Industrial sockets and accessories	No.	83			
6	Split Air Conditioners – 2 TR with timer	No.	166			
7	Pre-fabricated Shelter	Set	83			
8	Indoor CCTV Dome Camera	No.	166			
9	Indoor CAT 6 patch cord 10 mtr.	No.	83			
10	Access Control system with Biometric + Smart card Reader & Smart Card, Push button, Magnetic lock and accessories	Set	83			
11	Spare Cable Box	No.	83			
12	Passive Cabling & Accessories	Lot.	83			
13	Site Preparation(partition for UPS, exhaust fan, painting, light & fans) and Electrical works including earthing	site	83			
<b>G OLT</b>						
1	4 port GPON OLT (at PoP location)	No.	94			
2	8 port GPON OLT (at PoP location)	No.	284			
<b>H. DWDM Solution</b>						
1	DWDM Solution at NOC and all Core PoP locations	No.	14			
<b>I. End Office</b>						
1	300 VA UPS with 30 min Battery backup to be supplied along with the enclosure	No.	30,438			
2	2x5 way 10 amp PDU	No.	30,438			
3	9U Network Rack 19" with provision to mount the OLT	No.	30,438			
4	GPON OLT (at end office)	No.	30,438			
<b>J. Installation, Commissioning &amp; Testing</b>						

**Volume- I**

#	Item	UoM	Total Qty	Unit price	Total price without tax	Tax rate
1	2	3	4	5	6 = (5) (4)	7
1	Installation, Commissioning & Testing of all IT/Non IT Components at NOC	Set	1			
2	Installation, Commissioning & Testing of all IT/Non IT Components at Core PoPs incl. OLT	Set	14			
3	Installation, Commissioning & Testing of all IT/Non IT Components at Aggregation PoPs incl. OLT	Set	87			
4	Installation, Commissioning & Testing of all IT/Non IT Components at Pre-Aggregation PoPs incl. OLT	Set	194			
5	Installation, Commissioning & Testing of all IT/Non IT Components at Spur PoPs incl. OLT	Set	83			
6	Installation, Commissioning & Testing of DWDM equipment at all Core PoPs & NOC	Set	1			
7	Installation, Commissioning & Testing of all IT/Non IT Components at end offices	Set	30,438			
<b>K. Others</b>						
1	Training	Lot.	1			
<b>Total CAPEX for IT &amp; Non- IT</b>						
<b>Total CAPEX</b>						

Table 26: CAPEX for Package A

**8.4 BoQ for Package B\*** (to be filled in the excel provided)

SL No	Items	UoM	Quantity	Unit Price	Total Price without tax	Tax Rate	Tax Amount	Total Amount	Total Amount in words
1	2	3	4	5	6 = (5) (4)	7	8 = (6) (7)	9 = (6) + (8)	10
1	Supply of 48 Fibre (DWSM) OPGW optic fibre cable with 5Kms Spare and testing equipment as per Technical specification, at three System Operation Circles at Kannur, Kalamassery & Thiruvananthapuram.	Km	2900.49						
2	Supply of Hardware sets for 48 Fibre (DWSM)OPGW OFC including cable fittings and accessories and for the 5Kms OPGW Spare cable at three System Operation Circles at Kannur, Kalamassery & Thiruvananthapuram.	Km	2900.49						
3	Joint box four way for 48 fibre OPGW cable	No	800						
4	FODP (96 fibre) indoor type with FC-PC coupling and pig tails (5 mtr each)	No	100						
5	FODP (48 fibre) indoor type with FC-PC coupling and pig tails (5 mtr each)	No	160						
6	Non-Metallic armoured underground Optic Fibre approach cable, 48 Fibre, DWSM.	No	75						
7	PLB HDPE pipe O.D 40 mm including all accessories	No	75						
8	Survey of route, design and submission of drawing for approval and detailed list of materials required for the work and providing as built drawing after the execution of work.	Km	2900.49						
9	Installation of 48 Fibre (DWSM) OPGW optic fibre cable on 220kV & 110kV towers, fixing of hardware set, cable fittings and accessories and installation of joint boxes	Nos	2900.49						



**Volume- I**

SL No	Items	UoM	Quantity	Unit Price	Total Price without tax	Tax Rate	Tax Amount	Total Amount	Total Amount in words
1	2	3	4	5	6 = (5) (4)	7	8 = (6) (7)	9 = (6) + (8)	10
	and its terminations etc. Pre-installation test (Drum test), Post installation test, splicing and Link test (End to End).								
10	Installation of non-metallic armoured underground optical fibre approach cable (UG OFC 48 fibre DWSM) at 220kV & 110kV Substations through existing cable trench by removing concrete slab, installation of HDPE pipe etc. Pre-installation test (Drum test), Post installation test, splicing and Link test (End to end) and placing back concrete slabs as good as in original condition.	Nos	75						
11	Installation, testing and commissioning of FODP 96 fibre and termination of OPGW & OF approach cable.	Nos	100						
12	Installation, testing and commissioning of FODP 48 fibre and termination of OPGW & OF approach cable.	Km	160						

Table 27: BoQ for Package B

**8.5 Optional Items**

Sl. No.	Item	Total Qty	UoM	GST in %	GST IN INR	TOTAL AMOUNT Without Taxes	TOTAL AMOUNT With Taxes	Total Amount with tax in words
1	<add item 1>		No.					
2	<add item 2>		No.					
3	<add item ...n.>		No.					

Table 28: BoQ for optional items

**Note** Optional items are not considered for Commercial evaluation. The above table shall be submitted as a separate document on the Company Letterhead of the Bidder/Lead Bidder and signed by the Authorized signatory. Document

format should be PDF and should be uploaded as part of Commercial Bid. In case there are no optional items to be quoted, Bidder may upload the PDF with the columns marked as “Not Applicable”.

**8.6 O&M for both Packages \*(to be filled in the excel provided)**

Sl. No.	Item	Total Qty	UoM	Total Unit Cost	Tax %	Total Tax Amount	Total Cost with Taxes
1	2	3	4	5 = (3) x	(4) 6	7 = (5) (6)	8 = (5) (7) +
1	<b>OPEX per PoP</b>						
1.1	Y1 (Cost per quarter)	1	No				
1.2	Y2 (Cost per quarter)	1	No				
1.3	Y3 (Cost per quarter)	1	No				
1.4	Y4 (Cost per quarter)	1	No				
1.5	Y5 (Cost per quarter)	1	No				
1.6	Y6 (Cost per quarter)	1	No				
1.7	Y7 (Cost per quarter)	1	No				
2	<b>OPEX for per km of OPGW Cable</b>						
2.1	Y1 (Cost per quarter)	1	Km				
2.2	Y2 (Cost per quarter)	1	Km				
2.3	Y3 (Cost per quarter)	1	Km				
2.4	Y4 (Cost per quarter)	1	Km				
2.5	Y5 (Cost per quarter)	1	Km				
2.6	Y6 (Cost per quarter)	1	Km				
2.7	Y7 (Cost per quarter)	1	Km				
3	<b>OPEX for per km of ADSS</b>						
3.1	Y1 (Cost per quarter)	1	Km				
3.2	Y2 (Cost per quarter)	1	Km				
3.3	Y3 (Cost per quarter)	1	Km				
3.4	Y4 (Cost per quarter)	1	Km				
3.5	Y5 (Cost per quarter)	1	Km				
3.6	Y6 (Cost per quarter)	1	Km				
3.7	Y7 (Cost per quarter)	1	Km				
4	<b>OPEX for per km of drop Cable</b>						
4.1	Y1 (Cost per quarter)	1	Km				
4.2	Y2 (Cost per quarter)	1	Km				
4.3	Y3 (Cost per quarter)	1	Km				
4.4	Y4 (Cost per quarter)	1	Km				
4.5	Y5 (Cost per quarter)	1	Km				
4.6	Y6 (Cost per quarter)	1	Km				
4.7	Y7 (Cost per quarter)	1	Km				
5	<b>OPEX for per km of UG Cable</b>						
5.1	Y1 (Cost per quarter)	1	Km				
5.2	Y2 (Cost per quarter)	1	Km				
5.3	Y3 (Cost per quarter)	1	Km				
5.4	Y4 (Cost per quarter)	1	Km				

Sl. No.	Item	Total Qty	UoM	Total Unit Cost	Tax %	Total Tax Amount	Total Cost with Taxes
1	2	3	4	5 = (3) x (4)	6	7 = (5) (6)	8 = (5) (7) +
5.5	Y5 (Cost per quarter )	1	Km				
5.6	Y6 (Cost per quarter )	1	Km				
5.7	Y7 (Cost per quarter )	1	Km				
6	<b>OPEX per end institution</b>						
6.1	Y1 (Cost per quarter )	1	No				
6.2	Y2 (Cost per quarter )	1	No				
6.3	Y3 (Cost per quarter )	1	No				
6.4	Y4 (Cost per quarter )	1	No				
6.5	Y5 (Cost per quarter )	1	No				
6.6	Y6 (Cost per quarter )	1	No				
6.7	Y7 (Cost per quarter )	1	No				
7	<b>OPEX for NOC</b>						
7.1	Y1 (Cost per quarter )	1	No				
7.2	Y2 (Cost per quarter )	1	No				
7.3	Y3 (Cost per quarter )	1	No				
7.4	Y4 (Cost per quarter )	1	No				
7.5	Y5 (Cost per quarter )	1	No				
7.6	Y6 (Cost per quarter )	1	No				
7.7	Y7 (Cost per quarter )	1	No				
8	<b>AMC for active equipment under Package A</b>						
8.1	Y6 (YEARLY COST)						
8.2	Y7 (YEARLY COST)						

Table 29: O&M charges

**Note:-**

- OPEX will include the manpower cost and any support cost towards for any hardware, software

### 8.7 Price Bid Format

Sl. No.	Item	Value
1.	NPV	
2.	CAPEX of Package A	
3.	CAPEX of Package B	
4.	Total CAPEX	
5.	Year wise investment	
6.	C1	
7.	C2	
8.	C3	
9.	C4	
10.	C5	
11.	C6	
12.	C7	
13.	C8	
14.	C9	

Table 30: Price Bid Format

## 9 Format for Performance Bank Guarantee

(To be submitted on non-judicial stamp paper of appropriate value purchased in the name of the issuing Bank)

From  
Bank: .....

To  
Managing Director  
[Address]

Dear Sir,

1. Whereas you (the "PURCHASER") have entered into a contract No. \_\_\_\_\_ dated \_\_\_\_\_ (hereinafter referred to as the "said Contract") with M/s \_\_\_\_\_ (hereinafter referred to as the "SELLER") for supply of goods as defined in the said Contract and whereas the SELLER has undertaken to produce a bank guarantee for \_\_\_ % of total contract value amounting to \_\_\_\_\_ (amount of the guarantee in figures and words) to secure its obligations to the PURCHASER in accordance with the said Contract.
2. We \_\_\_\_\_ (the Bank) hereby expressly, irrevocably and unreservedly undertake and guarantee as principal guarantor on behalf of the SELLER that, we will pay you on your demand declaring the SELLER to be in default under the said Contract, without demur or contest, all and any sum up to a maximum of Rupees \_\_\_\_\_ only. Your written demand shall be conclusive evidence to us that such repayment is due under the terms of the said Contract.
3. We undertake to effect payment upon receipt of such written demand, notwithstanding any dispute or disputes raised by the SELLER in any suit pending before any Court, Tribunal, Arbitrator or any other authority, our liability under this present being absolute and unequivocal.
4. We shall not be discharged or released from this undertaking and guarantee by any arrangements or variations made between you and the SELLER, indulgence to the SELLER by you or by any alterations in the obligation of the SELLER or by any forbearance whether as to payment, time, performance or otherwise.
5. In no case shall the amount of this guarantee be increased.
6. This guarantee shall remain in full force and effect **3 months** beyond expiry of the warranty period as specified in the contract i.e. up to \_\_\_\_\_ (expiry date) *or until the PURCHASER has signed the Final Acceptance Certificate (FAC) and has received the contractually agreed Warranty Bond as per Contract.* In case of delay in fulfilment of obligations by the SELLER, the expiry date shall be extended by us as per intimation from the SELLER.
7. Unless a demand or claim under this guarantee is made to us in writing on or before the aforesaid expiry date or extended expiry date, all your rights under this guarantee shall be forfeited and we shall be discharged from the liabilities hereunder.

**Volume- I**

---

8. This guarantee shall be continuing guarantee and shall not be discharged by any change in the constitution of the Bank or in the constitution of the SELLER.
9. We lastly undertake not to revoke this guarantee during its currency except with the previous consent of the PURCHASER in writing.

Yours faithfully,  
For \_\_\_\_\_ Bank  
(Authorized Signatory)

Place: \_\_\_\_\_  
Date: \_\_\_\_\_ Seal of the Bank

**Note:**

1. *No substantial changes to the content of this format is allowed.*

## 10 Integrity Pact

### INTEGRITY PACT

#### 1. GENERAL

1.1 This pre-bid contract Agreement (hereinafter called the Integrity Pact) is made on .....day of the month..... 20..... between, the Kerala Fibre Optic Network Ltd. acting through its Managing Director (hereinafter called the "**Authority**" which expression shall mean and include, unless the context otherwise requires, his successors in the office and assigns) and the First Party, proposes to procure (name of the Stores/Equipment/Work/Service) and M/s.....represented by.....(Hereinafter called the "Bidder/Seller", which expression shall mean and include, unless the context otherwise requires, his successors and permitted assigns) as the Second Party, is willing to offer/ has offered.

1.2. WHEREAS the BIDDER is a Private Company/Public Company/ Government Undertaking/ Partnership firm, constituted in accordance with the Applicable Laws in the matter and the AUTHORITY is an agency of the Government, performing its function on behalf of the Government of Kerala.

#### 2. OBJECTIVES

2.1. Enabling the AUTHORITY to obtain the desired Stores/Equipment/Work/Service at a competitive price in conformity with the defined specifications by avoiding the high cost and the distortionary impact of corruption on public procurement, and

2.2. Enabling BIDDERS to abstain from bribing or indulging in any corrupt practices in order to secure the contract by providing assurance to them that their competitors will also abstain from bribing any corrupt practices and the AUTHORITY will commit to prevent corruption, in any form, by its official by following transparent procedures.

#### 3. COMMITMENTS OF THE TENDERING AUTHORITY

3.1. The AUTHORITY undertakes that no official of the AUTHORITY, connected directly or indirectly with the contract, will demand, take promise for or accept, directly or through intermediaries, any bribe, consideration, gift, reward, favour or any material or immaterial benefit or any other advantage from the BIDDER, either for themselves or for any person, organization or third party related to the contract in exchange for an advantage in the Bidding Process, bid evaluation, contracting or implementation process related to the contract.

3.2. The AUTHORITY will, during the pre-contract stage, treat BIDDERS alike, and will provide to all BIDDERS the same information and will not provide any such information to any particular BIDDER which could afford an advantage to that particular BIDDER in comparison to the other BIDDERS.

3.3. All the officials of the AUTHORITY will report the appropriate Government office any attempted or completed breaches of the above commitments as well as any substantial suspicion of such a breach. In case any such preceding misconduct on the part of such official(s) is reported by the BIDDER to the AUTHORITY with the full and verifiable facts and the same prima facie found to be correct by the AUTHORITY, necessary disciplinary proceedings, or any other action as deemed, fit, including criminal proceedings may be initiated by the AUTHORITY and such a person shall be debarred from further dealings related to the contract process. In such a case while an enquiry is being conducted by the AUTHORITY the proceedings under the contract would not be stalled.

#### 4. COMMITMENTS OF BIDDERS

4.1. The BIDDER will not offer, directly or through intermediaries, any bribe, gift, consideration, reward, favour, any material or immaterial benefit or other advantage, commission, fees, brokerage or inducement to any official of the AUTHORITY, connected directly or indirectly with the bidding process, or to any person, organization or third party related to the contract in exchange for any advantage in the bidding, evaluation, contracting and implementation of the contract.

4.2. The BIDDER further undertakes that it has not given, offered or promised to give, directly or indirectly any bribe, gift, consideration, reward, favour, any material or immaterial benefit or other advantage, commission, fees, brokerage, or inducement to any official of the AUTHORITY or otherwise in procuring the Agreement or forbearing to do or having done any act in relation to the obtaining or execution of the contract or any other contract with the

Government for showing or forbearing to show favour or dis-favour to any person in relation to the contract or any other contract with the Government.

4.3. The BIDDER further confirms and declares to the AUTHORITY that the BIDDER in the original Manufacture/Integrator/Authorized government sponsored export entity of the stores and has not engaged any individual or firm or company whether Indian or foreign to intercede, facilitate or in any way to recommend to the AUTHORITY or any of its functionaries, whether officially or unofficially to the award of the contract to the BIDDER, nor has any amount been paid, promised or intended to be paid to any such individual, firm or company in respect of any such intercession, facilitation or recommendation.

4.4. The BIDDER, either while presenting the bid or during pre-contract negotiations or before signing the Agreement, shall disclose any payment he has made, is committed to or intends to make to officials of the AUTHORITY or their family members, agents, brokers or any other intermediaries in connection with the contract and the details of services agreed upon for such payments.

4.5. The BIDDER will not collude with other parties interested in the contract to impair the transparency, fairness and progress of the Bidding Process, bid evaluation, contracting and implementation of the contract.

4.6. The BIDDER will not accept any advantage in exchange for any corrupt practice, unfair means and illegal activities.

4.7. The BIDDER shall not use improperly, for purpose of competition or personal gain, or pass on to others, any information provided by the AUTHORITY as part of the business relationship, regarding plans, technical proposal and business details, including information contained in any electronic data carrier. The BIDDER also undertakes to exercise due and adequate care lest any such information is divulged.

4.8. The BIDDER commits to refrain from giving any complaint directly or through any other manner without supporting it with full and verifiable facts.

4.9. The BIDDER shall not instigate or cause to instigate any third person to commit any of the acts mentioned above.

### **5. PREVIOUS TRANSGRESSION**

5.1. The BIDDER declares that no previous transgression occurred in the last three years immediately before signing of this Integrity Pact with any other company in any country in respect of any corrupt practices envisaged hereunder or with any Public Sector Enterprise in India or any Government Department in India that could justify BIDDER's exclusion from the tender process.

5.2. If the BIDDER makes incorrect statement on this subject, BIDDER can be disqualified from the tender process or the contract, if already awarded, can be terminated for such reason.

### **6. EARNEST MONEY (SECURITY DEPOSIT)**

**Every BIDDER while submitting commercial bid, shall deposit an amount as specified Money/Security Deposit online through e-procurement portal**

6.1. No interest shall be payable by the AUTHORITY to the BIDDER on Earnest Money/Security Deposit for the period of its currency.

### **7. SANCTIONS FOR VIOLATIONS**

7.1. Any breach of the aforesaid provisions by the BIDDER or any one employed by it or acting on its behalf (whether with or without the knowledge of the BIDDER) shall entitle the AUTHORITY to take all or any one of the following actions, wherever required:-

(i) To immediately call off the pre contract negotiations without assigning any reason or giving any compensation to the BIDDER. However, the proceedings with the other BIDDER(s) would continue.

(ii) To forfeit fully or partially the Earnest Money Deposit (in pre-contract stage) and/or Security Deposit/Performance Bond (after the contract is signed), as decided by the AUTHORITY and the AUTHORITY shall not be required to assign any reason therefore.



- (iii) To immediately cancel the contract, if already signed, without giving any compensation to the BIDDER.
- (iv) To recover all sums already paid by the AUTHORITY, and in case of the Indian BIDDER with interest thereon at 2% higher than the prevailing Prime Lending Rate while in case of a BIDDER from a country other than India with interest thereon at 2% higher than the LIBOR. If any outstanding payment is due to the BIDDER from the AUTHORITY in connection with any other contract such outstanding payment could also be utilized to recover the aforesaid sum and interest.
- (v) To encash the advance bank guarantee and performance bond/warranty bond, if furnished by the BIDDER, in order to recover the payments, already made by the AUTHORITY, along with interest.
- (vi) To cancel all or any other contracts with the BIDDER and the BIDDER shall be liable to pay compensation for any loss or damage to the AUTHORITY resulting from such cancellation/rescission and the AUTHORITY shall be entitled to deduct the amount so payable from the money(s) due to the BIDDER.
- (vii) To debar the BIDDER from participating in future Bidding Processes of the Government of Kerala for a minimum period of five years, which may be further extended at the discretion of the AUTHORITY.
- (viii) To recover all sums paid in violation of this Pact by BIDDER(s) to any middlemen or agent or broken with a view to securing the contract.
- (ix) In cases where irrevocable Letters of Credit have been received in respect of any contract signed by the AUTHORITY with the BIDDER, the same shall not be opened.
- (x) If the BIDDER or any employee of the BIDDER or any pers on acting on behalf of the BIDDER, either directly or indirectly, is closely related to any of the officers of the AUTHORITY, or alternatively, if any close relative of an officer of the AUTHORITY has financial interest/stake in the BIDDER's firm, the same shall be disclosed by the BIDDER at the time of filling of tender. Any failure to disclose the interest involved shall entitle the AUTHORITY to rescind the contract without payment of any compensation to the BIDDER

The term 'close relative' for this purpose would mean spouse whether residing with the Government servant or not, but not include a spouse separated from the Government servant by a decree or order of a competent court; son or daughter or step son or step daughter and wholly dependent upon Government servant, but does not include a child or step child who is no longer in any way dependent upon the Government servant or of whose custody the Government servant has been deprived of by or under any Applicable Law; any other person related, whether by blood or marriage, to the Government servant or to the Government servant's wife or husband and wholly dependent upon Government servant.

(xi) The BIDDER shall not lend to or borrow any money from or enter into any monetary dealings or transactions, directly or indirectly, with any employee of the AUTHORITY, and if he does so, the AUTHORITY shall be entitled forthwith to rescind the contract and all other contracts with the BIDDER. The BIDDER shall be liable to pay compensation for any loss or damage to the AUTHORITY resulting from such rescission and the AUTHORITY shall be entitled to deduct the amount so payable from the money(s) due to the BIDDER.

7.2. The decision of the AUTHORITY to the effect that a breach of the provisions of this pact has been committed by the BIDDER shall be final and conclusive on the BIDDER. However, the BIDDER can approach the Monitor(s) appointed for the purposes of this Pact.

## **8. FALL CLAUSE**

8.1. The BIDDER undertakes that he has not supplied/is not supplying similar product/systems or subsystems at a price lower than that offered in the present bid in respect of any other Department of the Government of Kerala or PSU and if it is found at any stage that similar product/systems or sub systems was supplied by the BIDDER to any other Department of the Government of Kerala or a PSU at a lower price, then that very price, with due allowance for elapsed time, will be applicable to the present case and the difference in the cost would be refunded by the BIDDER to the AUTHORITY, if the contract has already been concluded.

## **9. INDEPENDENT MONITORS**

9.1. The AUTHORITY will appoint Independent Monitors (hereinafter referred to as Monitors) for this Pact.

9.2. The task of the Monitors shall be to review independently and objectively, whether and to what extent the parties comply with the obligations under this Pact.

9.3. The Monitors shall not be subject to instructions by the representatives of the parties and perform their functions neutrally and independently.

9.4. Both the parties accept that the Monitors have the right to access all the documents relating to the project/procurement, including minutes of meetings. The Monitor shall be under contractual obligation to treat the information and documents of the BIDDER/Sub-Selected Bidder(s) with confidentiality.

9.5. As soon as the Monitor notices, or has reason to believe, a violation of this Pact, he will so inform the Authority designated by the AUTHORITY.

9.6. The Monitor will submit a written report to the designated official of AUTHORITY/Secretary in the Department/within 8 to 10 weeks from the date of reference or intimation to him by the AUTHORITY/BIDDER and, should the occasion arise, submit proposals for correcting problematic situations

**10. FACILITATION OF INVESTIGATION**

In case of any allegation of violation of any provisions of this Pact or payment of commission, the AUTHORITY or its agencies shall be entitled to examine all the documents including the Books of Accounts of the BIDDER and the BIDDER shall provide necessary information of the relevant documents and shall extend all possible help for the purpose of such examination.

**11. LAW AND PLACE OF JURISDICTION**

This Pact is subject to Indian Law, the place of performance and jurisdiction shall be the seat of the AUTHORITY.

**12. OTHER LEGAL ACTIONS**

The actions stipulated in this Integrity Pact are without prejudice to any other legal action that may follow in accordance with the provisions of the any other Applicable Law in force relating to any civil or criminal proceedings.

**13. VALIDITY**

13.1. The validity of this Integrity Pact shall be from the date of its signing and extend up to 8 years or the complete execution of the contract to the satisfaction of both the AUTHORITY and the BIDDER/Seller whichever is later. In case BIDDER is unsuccessful, this Integrity Pact shall expire after six months from the date of the signing of the contract.

13.2. If one or several provisions of this Pact turn out to be invalid; the remainder of this Pact shall remain valid. In such case, the parties will strive to come to an agreement to their original intentions.

14. The parties hereby sign this

Integrity Pact

At.....on.....

**KFON Ltd.**

**BIDDER**

\_\_\_\_\_ [Signature]

\_\_\_\_\_ [Signature]

\_\_\_\_\_ [Name]

\_\_\_\_\_ [Name]

\_\_\_\_\_ [Designation]

\_\_\_\_\_ [Designation]

**Witness**

**Witness**

- 1.
- 2.

- 1.
- 2.

# 11 Draft Master Service Agreement (MSA)

(To be printed on Stamp Paper of appropriate value)

This Master Services AGREEMENT (hereinafter the “Agreement”) is made at \_\_\_\_\_, Thiruvananthapuram, Kerala, on this \_\_\_\_ day of \_\_\_\_\_, 2018,

BETWEEN

Kerala Fibre Optic Network Ltd., Thiruvananthapuram, Kerala hereinafter referred to as “Authority” (which expression unless repugnant to the context therein shall include its administrator and permitted assignees) of the FIRST PART;

AND

-----a company registered under the Companies Act, 1956, having its registered office at -----  
-----, hereinafter referred to as “Systems Integrator” or “SI”, (which expression unless repugnant to the context therein, shall include its successors, administrators, executors and permitted assignees), of the SECOND PART.

*[In case the work is awarded to a Consortium, then all parties to the Consortium shall execute this Agreement on the terms shall apply to the consortium members mutatis mutandis. Further, the consortium members shall be severally liable for all obligations undertaken this Agreement.]*

And whereas Authority published the Tender to seek services of a reputed firm as a Systems Integrator for Implementation of Kerala Fibre Optic Network and Reliable Communication & Data Acquisition Network.

And whereas M/s. ----- has submitted its proposal to Implementation of Kerala Fibre Optic Network and Reliable Communication & Data Acquisition Network;

AND whereas Authority has selected M/s.....as Successful Bidder on the basis of the proposal submitted in response to the Tender and issued Letter of Intent dated .....to the Successful Bidder who in turn signed and returned the acceptance of Letter of Intent.

And whereas Authority and M/s. ----- have decided to enter into this Agreement to govern their mutual rights and obligations with respect to provision of goods and services and implementation of the Project on the terms and conditions stipulated hereinafter.

NOW, THEREFORE, in consideration of the premises covenants and promises contained herein and other good and valuable considerations, the receipt and adequacy of which is hereby acknowledged, the parties intending to be bound legally, IT IS HEREBY AGREED between the Parties as follows:

## 1. Definitions

Terms and expressions used in this Agreement shall have the meanings set out herein below. Other terms used in this Agreement are defined where they are used and have the meanings there indicated. Unless otherwise specifically defined, those terms, acronyms and phrases in this Agreement that are utilized in the information technology services industry or other pertinent business context shall be interpreted in accordance with their generally understood meaning in such industry or business context.

- a. “Authority” means Kerala Fibre Optic Network Ltd. acting for and on behalf of the Government of Kerala and represented by the Managing Director, Kerala Fibre Optic Network Ltd.;

- b. "Contract" or "Agreement" means this Master Services Agreement entered into between Authority and the Systems Integrator including all attachments, schedules, annexure thereto and all documents incorporated by reference therein and all amendments, corrigendum /corrigenda, changes thereto;
- c. "Systems Integrator" means M/s. ----- interchangeably referred to as "SI" in the contract; and "Tender" or "RfP" means the Tender or RfP published by Managing Director, Kerala State IT Infrastructure Ltd., on behalf of Kerala Fibre Optic Network Ltd. (Tender No:**KSITIL/MD/KFON/18/1852** dt: **14/06/2018**) and the subsequent Corrigenda / Clarifications issued.
- d. "Go Live" date means the day after the date on which the proposed solution becomes operational after successful conclusion of all acceptance tests to the satisfaction of Authority and the Authority has issued a Go-Live certificate.
- e. "Deliverable" means goods, services, software, applications, feeds, analytics, information and all other products, infrastructure and services etc. to be delivered by the Systems Integrator in pursuance of the Agreement as defined more elaborately in the RfP and includes any action / output generated by the SI while discharging its contractual obligations.
- f. "Assets" refer to all the hardware / software / network or any other information technology infrastructure components/ data / documentations / manuals / catalogues / brochures / Deliverables used for the Project and or any other facilities leased/owned/operated by the Systems Integrator or by the Authority, exclusively in terms of ensuring their usability for the delivery of the Deliverables/Services as per this Agreement;
- g. Control means the terms control as defined in section 2 (27) of the Companies Act, 2013
- h. Effective Date shall have the same meaning ascribed to it in Clause 4;
- i. Force Majeure shall have the same meaning ascribed to it in Clause 20;
- j. Intellectual Property Rights means all copyright, patent, trademarks, trade secrets and all other intellectual property rights including all rights in written designs, rights in databases and bespoke software / pre-existing work including its up-gradation and compilation rights (whether or not any of these are registered and including application for registration);
- k. Parties means Authority and the Systems Integrator (and consortium members, if any) for the purposes of this Agreement and "Party" shall be interpreted accordingly;
- l. Performance Security means the performance bank guarantee provided by SI from any Scheduled Commercial Bank/Nationalized Bank in favour of the Authority.
- m. Timelines means the timelines for performance of scope of work as described in the Agreement and the RfP;
- n. Services means the services delivered or to be delivered by the Systems Integrator under this Agreement using the tangible and intangible assets created, procured, installed, managed and operated by the Systems Integrator including the tools of information and communications technology and includes but is not limited to the list of services specified in the RfP;
- o. Service Level means the level of service and other performance criteria which will apply to the Services delivered by the Systems Integrator and as described in the Agreement and the RfP;
- p. SLA means the Performance and Maintenance SLA mentioned in the Agreement and the RfP;
- q. Term shall have the same meaning ascribed to it in Clause 4;

- r. Goods means to include all hardware, equipment, instruments, machinery, material, electronic items, networking equipment, switches, routers, cables and other tangible goods/items etc., and includes their user manuals, technical manuals, operating manuals, service mechanisms, policies and guidelines (such as security related, data migration related) and all its modifications, provided or to be provided by Systems Integrator to Authority under this Agreement;
- s. COTS means Commercial off-the-shelf product(s).
- t. Total Value of Project/Total Project Value means [\_\_\_\_\_] i.e. the amount quoted by the Systems Integrator (inclusive of taxes) in its commercial bid.
- u. 'Replacing Systems Integrator' shall mean any third party that the Authority or its nominated agencies appoint to replace the Systems Integrator upon expiry of the Term or earlier termination of this Agreement to undertake the Services or part thereof;

## **2. Interpretation**

In this Agreement, unless otherwise specified:

- a) references to Clauses, Sub-Clauses, Paragraphs, Schedules and Annexures are to clauses, sub-clauses, paragraphs, schedules and annexures to this Agreement;
- b) words denoting the singular include the plural and vice versa and use of any gender includes the other genders;
- c) references to a 'company' shall be construed so as to include any company, corporation or other body corporate, wherever and however incorporated or established;
- d) references to a 'person' shall be construed so as to include any individual, firm, company, government, state or agency of a state, local or municipal authority or government body or any joint venture, association or partnership (whether or not having separate legal personality);
- e) a reference to any statute or statutory provision shall be construed as a reference to the same as it may have been, or may from time to time be, amended, modified or re-enacted;
- f) unless otherwise specified, any reference to a 'day' (including within the phrase 'business day') shall mean a period of 24 hours running from midnight to midnight;
- g) references to times are to Indian Standard Time;
- h) a reference to any other document referred to in this Agreement is a reference to that other document as amended, varied, novated or supplemented at any time; and
- i) all headings and titles are inserted for convenience only. They are to be ignored in the interpretation of this Agreement.

### **3. Priority of documents**

The documents forming this Agreement are to be taken as mutually explanatory of one another. The following order shall govern the priority of documents constituting this Agreement, in the event of a conflict between various documents; the documents shall have priority in the following order:

- i) this Agreement along with its schedules and annexures ;
- ii) Scope of Services for the Systems Integrator (hereby annexed **Annexure I**)
- iii) Tender Document issued by the Authority together with the Clarification & Corrigendum Documents published by the Authority subsequent to the Tender for this work (hereby annexed **Annexure II**)
- iv) LoI issued by the Authority to the Systems Integrator (hereby annexed **Annexure III**)
- v) System Integrator' "Technical Bid" and "Commercial Bid" submitted in response to the Tender (hereby annexed as **Annexure IV**)
- vi) Format of Change Control Notice **Annexure V**

### **4. Term of the Agreement**

This Agreement shall come into effect on <\*\*\*> 20---(insert the same date as 'T' in timelines) (hereinafter the 'Effective Date') and shall continue for a period of implementation time of 24 months and a period of 7 years post implementation ('Term').

In the event of implementation period getting extended beyond the above, for reasons not attributable to the Systems Integrator, Authority may at its sole discretion extend the term of the Agreement, on same terms and conditions. Authority also reserves the right to extend the Term for a period of two years, at its sole discretion, on same terms and conditions. Any extension beyond these two years shall be on mutually agreed terms and conditions.

### **5. Conditions Precedent**

#### **5.1.Provisions to take effect upon fulfilment of Conditions Precedent**

Subject to express terms to the contrary, the rights of Systems Integrator to receive payments, and obligation of Authority to make payments under this Agreement, shall take effect only upon fulfilment of all the Conditions Precedent set out below. However, Authority may, at any time at its sole discretion, waive fully or partially any of the Conditions Precedent for the Systems Integrator.

#### **5.2.Conditions Precedent for the Systems Integrator**

- a) The Systems Integrator shall be required to fulfil the Conditions Precedent which are as follows:
  - i. to provide an unconditional, irrevocable and continuing Performance Security/Guarantee for an amount equal to 10% of the Total CAPEX value of the Project from any Nationalized / Scheduled Commercial bank in the format as provided in the RfP; and
  - ii. the Systems Integrator to provide Authority certified true copies of its constitutional documents and board resolutions authorizing the execution, delivery and performance of this Agreement by the Systems Integrator.

### **6. Obligations of the Systems Integrator**

#### **6.1.Under the Agreement**

In addition to the other obligations of the Systems Integrator stated in the Agreement elsewhere and in the RfP, the Systems Integrator shall:

- a) Maintain minimum spare inventory at all times adequate to meet the service level shall be maintained.

- b) Ensure the integration of fibre and equipment and the software with hardware to be installed and the current Assets in order to ensure the smooth operations of the entire solution architecture to provide efficient services to Authority of this Project in an efficient and speedy manner;
- c) Systems Integrator shall not use Authority's data to provide services for the benefit of any third party without prior permission of the Authority.

### **6.2.Under The Service Level Agreements (SLAs)**

The Systems Integrator shall accomplish the scope of work under this Agreement as per the Timelines and as per the Service Level Agreements. If the Systems Integrator fails to achieve the Timelines due to reasons attributable to it, or if it fails to achieve the Service Levels (in the SLAs) for any reason whatsoever, the Systems Integrator shall be liable to pay penalty/liquidated damages as mentioned in the RfP. In case the Systems Integrator is not solely liable for the breach of Timelines, amount of liquidated damages shall be deducted on proportionate / pro rata basis depending upon the Systems Integrator's extent of fault in such breach of Timelines. Authority shall have the right to determine such extent of fault and liquidated damages in consultation with Systems Integrator. Payment of liquidated damages shall not be the sole and exclusive remedies available to Authority and the Systems Integrator shall not be relieved from any obligations by virtue of payment of such liquidated damages. The liquidated damages will be capped as mentioned in RfP. If the liquidated damages cross the cap on liquidated damages mentioned in the RfP, Authority shall have the right to terminate the Agreement for breach and consequences for such termination as provided in this Agreement shall be applicable.

### **6.3.Change of Control**

- i. In the event of a Change of Control of the Systems Integrator, the Systems Integrator shall promptly notify Authority of the same in the format set out as Annexure V of this Agreement.
- ii. In the event that the net worth of the surviving entity is less than that of the Systems Integrator prior to the Change of Control, the Authority may within 30 (thirty) days of becoming aware of such change in control, require a replacement of existing Performance Security (with same or higher value) furnished by the Systems Integrator from a guarantor acceptable to Authority (which may or may not be the Systems Integrator or any of its associated entities).
- iii. If such a guarantee is not furnished within 30 days of Authority requiring the replacement, Authority may exercise its right to terminate this Agreement within a further 30 (thirty) days by written notice, to become effective as specified in such notice.
- iv. Pursuant to termination, the consequences of termination as set out in this Agreement shall follow.

For the avoidance of doubt, it is expressly clarified that the internal reorganization of the Systems Integrator shall not be deemed an event of a change of control for purposes of this Clause unless the surviving entity is of less net worth than the predecessor entity.

### **6.4.Final testing and certification**

Except as otherwise provided in the RfP, the Project shall be governed by the mechanism of final acceptance testing and certification to be put into place by the Parties as under:

- i. Final testing and certification criteria will lay down a set of guidelines following internationally accepted norms and standards for testing and certification for all aspects of implementation covering fibre, software, hardware and networking including the processes relating to the installation, commissioning, running of the equipment, design of systems and sub- systems, testing, business process description, documentation, version control, change management, security, service oriented architecture, performance in relation to compliance with SLA metrics, interoperability, scalability, availability and compliance with all the technical and functional requirements of the RfP and this Agreement;
- ii. Final testing and certification criteria will consider conducting specific tests on the fibre, software, hardware, networking, security and all other aspects;

- iii. Final testing and certification criteria will establish appropriate processes for notifying the Systems Integrator of any deviations from the norms, standards or guidelines at the earliest instance after taking cognizance of the same to enable the Systems Integrator to take corrective action; etc. Final acceptance test criteria will also adhere to the requirements as detailed in the RfP.

## **7. Obligations of the Authority**

Without prejudice to any other undertakings or obligations of Authority under this Agreement or Tender, Authority shall perform the following:

- a) To provide any reasonable support through personnel to test the system during the Term;

To provide any reasonable support through personnel and/or test data during development, rollout, steady state operation, as well as, for any changes/enhancements in the system whenever required due to scope change that may arise due to business, delivery or statutory/regulatory reasons, provided that any enhancement/changes etc. to the system shall always be subject to prior written approval of Authority;

- b) To authorize the Systems Integrator to interact for implementation of the Project with external entities to the extent deemed necessary by Authority.

## **8. Acceptance of Deliverables and Testing**

### **8.1. Acceptance of Deliverables**

The successful completion of the Project requires the acceptance by Authority of all Deliverables prepared and delivered pursuant to the Project, including the System. The acceptance procedure described in this Clause is in addition to, and not in derogation of, the acceptance procedure laid down in the RfP and the two are to be read harmoniously. Upon completion of a Deliverable, Systems Integrator will notify Authority in writing that the Deliverable has been completed and, in the case of Deliverables constituted of fibre, equipment and/or software (“Operational Deliverables”), tested and/or certified as being ready for acceptance (“Ready for Acceptance”) by Authority. Promptly after receiving such notice, Authority will evaluate the Deliverable for acceptance in accordance with this Clause 8 or specific provisions provided in the RfP. The acceptance process outlined below shall not be deemed to extend the Timelines / scheduled completion date for any Deliverable specified in the RfP.

### **8.2. Acceptance Procedure**

Acceptance by Authority (“Acceptance”) requires that the Deliverables be confirmed in writing by Authority to meet applicable acceptance criteria (“Acceptance Criteria”) which, in the case of Operational Deliverables, will include the successful completion of agreed acceptance and performance testing and, in the case of the system as a whole, will include meeting the specifications, performance standards and functional requirements set out in the RfP. In the case of Deliverables that are component parts of the system, in addition to acceptance of the component Deliverables, the system will also be subject to Acceptance in its entirety. Systems Integrator shall prepare and propose the test procedures, which shall be described in the Acceptance Criteria for each Deliverable and shall be subject to agreement by Authority. While designing the acceptance test procedures the requirements as mentioned in the RfP need to be adhered. The Acceptance tests and test procedures shall be sufficiently broad in scope and rigorous so as to verify that the system and all other Deliverables meet all applicable specifications, acceptance criteria and performance requirements, including assurance that the Deliverables and the system meet such tests of operational integrity as may be reasonably required by Authority. In the case of the system, the Acceptance tests shall consist of unit tests and/or a system test. Acceptance procedures for written Deliverables (which are all Deliverables other than Operational Deliverables) and Operational Deliverables are as follows:

- (a) Written Deliverables:

- (i) The Systems Integrator may submit interim drafts of written Deliverables (e.g., system designs and documentation) to Authority for review. Authority agrees to review each interim draft within a reasonable period of time after receiving it from the Systems Integrator. When the Systems Integrator delivers a final written Deliverable to Authority, Authority will have the opportunity to



review such written Deliverable for an acceptance period of fifteen (15) working days or such other period as is stated in the RfP or the agreed Project Plan (the “Acceptance Period”). In all cases, Authority’s obligation to review a written Deliverable within the applicable Acceptance Period will be contingent on such written Deliverable being delivered to Authority as scheduled. If and to the extent any written Deliverable is delivered earlier or later than scheduled, the Acceptance Period for such written Deliverable shall be extended as reasonably necessary to accommodate the availability of Authority personnel responsible for reviewing such Deliverable. Similarly, if and to the extent multiple written Deliverables are delivered to Authority within an Acceptance Period, the Acceptance Period for all such written Deliverables shall be extended as reasonably necessary to accommodate the availability of Authority personnel responsible for reviewing them.

- (ii) Authority agrees to notify the Systems Integrator in writing by the end of the Acceptance Period either stating that the applicable written Deliverable is accepted / rejected in the form delivered by the Systems Integrator or describing with reasonable particularity any deficiencies that must be corrected prior to acceptance of such written Deliverable. If the Systems Integrator does not receive any such notice from Authority by the end of the Acceptance Period, the Systems Integrator shall promptly notify Authority in writing that no such notice has been received. Acceptance shall not be unreasonably withheld by Authority.
- (iii) If Authority delivers to the Systems Integrator a timely notice of rejection/deficiencies, the Systems Integrator will correct the described deficiencies as quickly as possible and, in any event, within ten (10) days after Authority notifies the Systems Integrator of the rejection/deficiencies (unless otherwise specified in the agreed Project Plan). Upon receipt of a corrected written Deliverable from the System Integrator, Authority will have a period of fifteen (15) working days to review the corrected written Deliverable.

(b) Operational Deliverables:

- (i) To the extent not already specified in the RfP or agreed Project Plan, prior to the date on which the Systems Integrator is scheduled to deliver each Operational Deliverable to Authority, both the Systems Integrator and Authority will agree upon the testing procedures for the Operational Deliverable, including without limitation detailed test cases and expected results (the “Acceptance Tests”). The Acceptance Tests will be designed to determine whether the Operational Deliverable contains any defects. Authority will have the opportunity during the Acceptance Period to evaluate and test each Operational Deliverable in accordance with the following procedures by executing the Acceptance Tests.
- (ii) When the Systems Integrator has completed an Operational Deliverable, it will deliver the Operational Deliverable at the Installation Site (if not already there), install such Deliverable (if not already installed), and perform an installation test reasonably acceptable to Authority to verify that the Deliverable has been properly delivered and installed. The Systems Integrator shall notify Authority when the Operational Deliverable is ‘Ready for Acceptance’, provided that, unless otherwise agreed, such notice shall not occur prior to the successful completion by the Systems Integrator of any installation tests. Such notice will start the Acceptance Period, which will be fifteen (15) working days or such other period as is stated in the RfP or agreed Project Plan. As was the case with written Deliverables, Authority’s obligation to review any Operational Deliverable within the applicable Acceptance Period will be contingent on such Operational Deliverable being delivered to Authority as scheduled. If and to the extent any Operational Deliverable is delivered earlier or later than scheduled, the Acceptance Period for such Operational Deliverable shall be extended as reasonably necessary to accommodate the availability of the Authority personnel responsible for reviewing such Operational Deliverable. Similarly, if and to the extent multiple Operational Deliverables are delivered to Authority within an Acceptance Period, the Acceptance Period for all Operational Deliverables shall be extended as reasonably necessary to accommodate the availability of the Authority personnel responsible for reviewing them.

- (iii) Authority shall notify the Systems Integrator in writing by the end of the Acceptance Period stating that the Operational Deliverable is accepted/rejected in the form delivered by the Systems Integrator or describing the defects as provided in sub clause 8.2 (b) (iv) below. If the Systems Integrator does not receive any notice of defects from Authority by the end of the Acceptance Period, the Systems Integrator shall promptly notify Authority in writing that no such notice was received.
- (iv) If Authority determines during the Acceptance Period that the Operational Deliverable as delivered by the Systems Integrator deviates from its approved specifications or otherwise fails to successfully complete applicable Acceptance Tests (or a defect), Authority will inform the Systems Integrator in writing, describing the defect(s) in sufficient detail to allow the Systems Integrator to recreate/rectify them. The Systems Integrator will correct any defects in an Operational Deliverable as quickly as possible after receiving Authority's notice of the defects and, in any event, within ten (10) days after receiving such notice (unless otherwise specified in the Project Plan/RfP), and provide the corrected Operational Deliverable to Authority for re-testing within such ten (10) day period.
- (v) Authority will have a reasonable additional period of time after receipt of the corrected Operational Deliverable to re-test it so as to confirm its proper functioning. The Systems Integrator will correct any further defects identified by Authority during the re-test as quickly as possible, but in no event more than ten (10) days after Authority notifies the Systems Integrator of the further defects, unless otherwise specified in the agreed Project Plan or RfP or agreed by Authority.

(c) Correction of Deficiencies in Deliverables

- (i) If the Systems Integrator is unable to correct all deficiencies preventing Acceptance of a Deliverable for which it is responsible after a reasonable number of repeated efforts (but not more than three (3), Authority may at its election:
  - allow the Systems Integrator to continue its efforts to make corrections; or
  - accept the Deliverable with its Deficiencies and deduct such proportionate amounts from the Systems Integrator's fees as deemed appropriate by Authority; or
  - terminate this Agreement for cause in accordance with the procedures set forth in Clause 28 (except that Authority is under no obligation to provide the Systems Integrator any further opportunity to cure) and recover its damages subject to the limitations set forth in this Agreement.

**9. Schedule of Payment / Payment Terms**

Total payment to the Systems Integrator for the execution of this Contract is INR ----- inclusive of all taxes, levies, fees, etc. Authority shall make the payment to the SI as per the schedule given in the Tender document

The quarterly payment shall be due at the end of every three months starting from the date of successful Go Live and shall be subject to strict adherence of the respective SLAs. If the Systems Integrator is liable for any penalty/liquidated damages as per the SLAs (refer to the clause no. 6 of this Agreement), the same shall be adjusted from quarterly payments due to the Systems Integrator.

The payment shall be inclusive of all taxes, duties, fees, levies, charges, and commissions as applicable under the relevant Laws of India. Should there be a change in applicable taxes / levies, the actual taxes / levies on the date of billing would prevail.

Authority will release the payment within 30 days of submission of valid, correct, undisputed invoice subject to the condition that invoice and all supporting documents produced are in order and work is performed to the satisfaction of Authority. Authority shall be entitled to delay or withhold the payment of any invoice or part of it delivered by SI,

where Authority disputes such invoice or part of it provided that such a dispute is bonafide. The disputed amount shall be settled in Resolution of dispute.

Payments will be subject to deduction of taxes as per applicable laws. Payments shall be subject to deduction of liquidated damages as per the SLAs.

### **10.Scope Extension**

Authority reserves the right to extend the scope of services for the price & timelines as provided in this Agreement. The SLAs applicable to this Agreement shall be liable for the additional items on mutual agreement.

#### **10.1Work Completion Timelines**

The Services are to be completed in accordance with the agreed timelines. Delay in meeting the timelines shall attract levying of Liquidated Damages as provided in the RFP.

#### **10.2Service Level Agreement (SLA)**

Authority is looking at a very professional approach in the Project implementation and its operations. Systems Integrator is expected to match these expectations of the service levels given in this Agreement. Any non-adherence to the SLAs would lead to the penalty, to be calculated as per the details given in Annexure II to this Agreement.

### **11.Use of Assets during the term**

During the Term of the Agreement Systems Integrator shall

- a) take all reasonable & proper care of the Assets which includes the entire hardware & software, network or any other information technology infrastructure components, Deliverables used for the Project & other facilities leased/owned by the Systems Integrator (for itself or for Authority or on behalf of Authority) exclusively in terms of their usability for the delivery of the Deliverables/Services as per this Agreement.
- b) keep all the tangible Assets in good & serviceable condition (reasonable wear & tear excepted) &/or the intangible Assets suitably upgraded subject to the relevant standards as stated in of the Tender to meet the SLAs mentioned in the contract as on the date the Systems Integrator takes control of and/or first uses the Assets & during the entire term of the Agreement.
- c) ensure that any instructions or manuals supplied by the manufacturer of the Assets for use of Assets & which are provided to the Systems integrator will be followed by the Systems Integrator & any person who will be responsible for the use of the Asset;
- d) take such steps as may be recommended by the manufacturer of the Assets & notified to the Systems Integrator or as may, in the reasonable opinion of the Systems Integrator, be necessary to use the Assets in a safe manner;
- e) provide a well-prepared documentation for users in the manual, a clear plan for training, education & hand holding the users & shall form part of hand holding phase until bringing up the users to use software solution with speed & efficiency;
- f) To the extent that the Assets are under the control of the System Integrator, keep the Assets suitably housed & in conformity with the Applicable Law from time to time applicable to them,
- g) Provide and facilitate access to Authority or its nominated agencies & any persons duly authorized by Authority to enter any land or premises on which the Assets are for the time being sited so as to inspect the same, subject to any reasonable third party requirements;
- h) Not, knowingly or negligently use or permit any of the Assets to be used in contravention of any statutory provisions or regulation or in any way contrary to the Applicable Law;

- i) Use the Assets exclusively for the purpose of providing the Services as defined in the Agreement;
- j) Not to sell, offer for sales, assign, mortgage, encumbrance, pledge, sub-let or lent out any of the Assets. Systems Integrator agrees that Systems Integrator will inform Authority immediately if Systems Integrator feels or comes to know that a charge may be / has been created over any Asset(s). In the event a charge is created over any of the Assets / Goods which are owned by Authority, Authority shall have the right to get the charge removed at the risk, cost, expense of the Systems Integrator and Systems Integrator shall make good all losses, damages, costs, fees, cess, duties, etc. borne or suffered by Authority due to creation of such charge and/or in removal of such charge and/or in discharging the obligations for removal of such charge.
- k) Use the Assets only in accordance with the terms hereof & those contained in the SLAs;
- l) At the end of implementation period, there shall be joint inspection by a team of Authority and Systems Integrator to assess the damages to the Assets, if any. If damage to the assets is found unacceptable to the Authority, then corresponding penalty/liquidated damages shall be recovered from SI from the fees payable.

### **12. Access To Authority To Certain Locations**

For so long as the Systems Integrator provides services to Authority's location, on a non-permanent basis and to the extent necessary, Authority shall, subject to compliance by the Systems Integrator with any safety and security guidelines which may be provided by Authority and notified to the Systems Integrator in writing, provide the Systems Integrator with:

- a) reasonable access to the location from where services are to be performed, in the same manner as granted to the Authority's employees, as the case may be;
- b) subject to 11(a) above, reasonable work space, access to office equipment as mutually agreed and other related support services in such location and at such other locations Authority, if any, as may be reasonably necessary for the Systems Integrator to perform its obligations hereunder.
- c) Access to locations, office equipment and services shall be made available to the Systems Integrator on an "as is, where is" basis by Authority. The Systems Integrator agrees to ensure that its employees, agents and SIs/sub-contractors shall not use the location, services and equipment referred to in RfP for the following purposes:
  - for the transmission of any material which is defamatory, offensive or abusive or of an obscene or menacing character; or
  - in a manner which constitutes violation of any law or a violation or infringement of the rights of any person, firm or company (including but not limited to rights of copyright or confidentiality).

### **13. Insurance Cover**

#### **13.1 Obligation to maintain insurance**

- a) During the Term Systems Integrator must maintain standard forms of comprehensive insurance including public liability insurance, personal indemnity, product liability, workers compensation as required by law;
- b) The above insurance policies shall be for appropriate values so as to cover risks of Systems Integrator under this Agreement.
- c) Systems Integrator shall be liable to pay premium for the insurance policy & shall ensure that each & every policy shall keep updated from time to time;

- d) Insurance of Goods: The Systems Integrator shall take insurance for the Goods and system for the Term at its own cost and expense for appropriate value in consultation with Authority and shall apprise Authority of the premium paid and claims made under the insurances on every 6 monthly basis.

In the event of any failure by the Systems Integrator to comply with the insurance requirements set out in this Agreement, Authority may, without in any way compromising or waiving any right or remedy, at law or in equity, upon five (5) days' written notice to the Systems Integrator, purchase such insurance, at the Systems Integrator's expense, provided that Authority shall have no obligation to do so and if Authority shall do so, the Systems Integrator shall not be relieved of or excused from the obligation to obtain and maintain such insurance amounts and coverages. All such reasonable costs incurred by Authority shall be promptly reimbursed by the Systems Integrator and/or may be withheld from any payment due to Systems Integrator. None of the requirements contained herein as to types, limits or Authority's approval of insurance coverage to be maintained by the Systems Integrator are intended to and shall not in any manner limit, qualify or quantify the liabilities and obligations assumed by the Systems Integrator under this Agreement, or otherwise provided by law.

### **13. ~~C~~ertificates of currency**

The Systems Integrator must, on request by the Authority, provide current relevant confirmation of insurance documentation from its insurance brokers certifying that it has insurance as required by this Clause. The Systems Integrator agrees to replace any coverage prior to the date of expiry/cancellation.

### **13. ~~N~~on-compliance**

Authority or its nominated agencies may, at its election, terminate this Agreement upon the failure of the Systems Integrator, or notification of such failure, to maintain the required insurance coverage. Inadequate insurance coverage for any reason shall not relieve the Systems Integrator of its obligations under this Agreement.

## **14. Ownership and IPRs**

### **14. ~~P~~roducts and fixes**

All COTS products and related solutions and fixes provided pursuant to this Agreement shall be licensed according to the terms of the license agreement packaged with or otherwise applicable to such product. Such licenses shall be bought on behalf of and in the name of Authority or mentioning Authority as the end user of such licenses. The Systems Integrator would be responsible for arranging any licenses associated with products. "Product" means any computer code, web-based services, or materials comprising commercially released, pre-release or beta products (whether licensed for a fee or no charge) and any derivatives of the foregoing which are made available to Authority for license which is published by product owner or its affiliates, or a third party. "Fixes" means product fixes that are either released generally (such as commercial product service packs) or that are provided to you when performing services (such as workarounds, patches, bug fixes, beta fixes and beta builds) and any derivatives of the foregoing. All intellectual property rights in any development/enhancement/customization etc. done on the COTS products pursuant to this Agreement shall be owned by Authority.

### **14. ~~B~~espoke development**

Upon acceptance of any bespoke development as per this Agreement or RfP, the ownership of all IPR rights in any and all bespoke development done during the Term for implementation of the Project under this Agreement will lie with Authority. The Systems Integrator shall provide source code, object code and all other relevant materials, artefacts etc. of all bespoke development to Authority and Authority shall own all IPRs in them. All material related to such bespoke development shall be treated as confidential information by the Systems Integrator. This will also include any developments on COTS.

### **14. ~~D~~eliverables and Pre-existing work of the Systems Integrator**

The ownership of all IPR rights in any and all documents, artefacts, etc. (including all training material) made during the Term for implementation of the Project under this Agreement will lie with Authority. Deliverables provided to Authority by Systems Integrator during the course of its performance under this Agreement, in which subject to the

foregoing provisions of this Article, all right, title and interest in and to such Deliverables, shall, as between Systems Integrator and Authority, immediately upon creation, vest in Authority. To the extent that the Systems Integrator Proprietary Information is incorporated within the Deliverables, Systems Integrator and its employees engaged hereby grant to Authority a worldwide, perpetual, irrevocable, non-exclusive, transferable, paid-up right and license to use, copy, modify (or have modified), transport to Authority facilities, and prepare from them, use and copy derivative works for the benefit of and internal use of Authority, of such Systems Integrator Proprietary Information, Authority rights pursuant to the preceding sentence include the right to disclose such Systems Integrator Proprietary Information to third party SIs solely for use on the Project provided that all such third party SIs execute, deliver and comply with any customary confidentiality and non-disclosure agreements reasonably required by Authority.

### **14.4. Third Party Products**

If license agreements are necessary or appropriate between the Systems Integrator and third parties for purposes of enabling / enforcing/implementing the provisions hereinabove, the Systems Integrator shall enter into such agreements at its own sole cost, expense and risk.

The SI shall execute all such agreements/documents and assist the Authority in filing all relevant applications, effect transfers and obtain all permits and approvals that may be necessary to effectively transfer and conserve the Intellectual Property Rights of the Authority at the cost of the Authority

### **15. Transfer of risk and ownership in goods**

- a) Subject to the terms of this Agreement, Systems Integrator shall sell, assign, convey, transfer and deliver to Authority, and Authority shall purchase, receive and accept from the Systems Integrator, all right, title and interest in and to the Goods required to be provided by the Systems Integrator as per the RfP. The Systems Integrator shall not make any substitute for the Goods of any other model, capacity, or manufacturer without the prior written consent of Authority which consent shall not be unreasonably delayed or withheld.
- b) The Systems Integrator shall arrange for delivery of the Goods to the delivery site identified by Authority (the "Delivery Site") as per the Timelines provided in the RfP unless otherwise notified by Authority. In addition to paying all transportation charges for the Goods, the Systems Integrator shall insure, and pay all insurance charges for the Goods.
- c) Title to and Ownership of the Goods designated as being purchased by Authority hereunder shall remain vested in Systems Integrator until written Acceptance and on Go Live of the Project by Authority under the terms hereof, at which time title to and ownership of such Goods shall transfer to the Authority. Upon transfer of ownership of the Goods to Authority, the Systems Integrator shall treat such Goods as Assets as detailed above in this Agreement. SI shall execute all such documents as may be necessary to give effect to such transfer of title and ownership at SI's own cost and expense.
- d) Notwithstanding the transfer of ownership of the Goods to Authority, the risk of loss in Goods shall remain with the Systems Integrator during the Term of the Agreement or till effective date of earlier termination of this Agreement.

### **16. Security and safety**

- a) The Systems Integrator will comply with the directions issued from time to time by Implementation of Kerala Fibre Optic Network and Reliable Communication & Data Acquisition Network and follow the industry standards related to the security and safety (including those as specified by Authority from time to time) in so far as it applies to the provision of the Services.
- b) Systems Integrator shall also comply with the Authority's information technology security and standard policies in force from time to time as applicable.
- c) Systems Integrator shall use reasonable endeavours to report forthwith in writing to the Authority all identified attempts (whether successful or not) by unauthorised persons either to gain access to or interfere with Authority's data, facilities or Confidential Information.
- d) The Systems Integrator shall upon reasonable request by Authority or its nominee(s) participate in regular meetings when safety and information technology security matters are reviewed.

- e) As per the provisions of this Agreement, Systems Integrator shall promptly report in writing to each the Authority any act or omission which they are aware that could have an adverse effect on the proper conduct of safety and information technology security at Authority's facilities.

### **17. Indemnity**

**17.1** The Systems Integrator undertakes to indemnify and hold harmless and defend the Authority, Kerala State Electricity Board Limited(KSEBL) and Kerala State Information Technology Infrastructure Ltd.(KSITIL) , at its expense and its officers, employees and agents promptly upon demand at any time and from time to time, from and against any and all losses, claims, damages, liabilities, costs (including reasonable attorney's fees and disbursements) and expenses (collectively, "Losses") to which the Authority may become subject, in so far as such Losses arise out of, in any way relate to, or result from

- (i) claims by third Parties that any Deliverable (or the access, use or other rights thereto) or any equipment, software, information, methods of operation or other intellectual property used, created, submitted etc. by Systems Integrator or sub-contractors pursuant to this Agreement infringes any intellectual property right (including, without limitation, a copyright, patent, trade mark, trade name, trade design etc.) of any third party provided the Systems Integrator will not indemnify the Authority or KSEBL or KSITIL, if such claim is caused by (a) the Authority's misuse or modification of the Deliverables; (b) the Authority's failure to use corrections or enhancements made available by the System Integrator; (c) the Authority's use of the Deliverables in combination with any product or information not owned or developed or supplied by the Systems Integrator or its sub-contractors. In addition to the foregoing indemnity obligations, if any of the Deliverables is or likely to be held to be infringing, the Systems Integrator shall at its expense and option either (i) procure the right for the Authority to continue using it, (ii) replace it with a non-infringing equivalent, (iii) modify it to make it non-infringing.
- (ii) any compensation / claim or proceeding by any third party against Authority or KSEBL or KSITIL arising out of any act, deed or omission by the Systems Integrator; or
- (iii) claim filed by a workman or employee engaged by the Systems Integrator for carrying out work related to this Agreement.

### **17.2 General Indemnity**

Subject to Sub-clause 17.3 below, the Systems Integrator shall keep the Authority, indemnified from and against all losses, claims, damages, compensation, litigation etc. including attorney's fees and damages on account of bodily injury, death or damage to tangible personal property arising in favour or any person, corporation or of her entity (including the Authority) attributable to the Indemnifying Party's performance or non -performance under this Agreement or Systems Integrator' negligence, wilful default, lack of due care or breach of terms of this Agreement.

### **17.3 Conditions for Indemnity**

- a) Without prejudice to the rights of the Authority in respect of indemnification for any claim, the indemnities set out in Sub-clause 17.1 and 17.2 above shall be subject to the following conditions:
- (i) The Authority, as promptly as practicable, shall inform the Systems Integrator in writing upon receipt of any notice of claim or proceedings setting out in reasonable particulars, the details of such notice of claim;
  - (ii) Immediately upon receipt of notification of any claim from the Authority, the Systems Integrator within a period of 5 (five) days from date of receipt of such notice from the Authority, notify the Authority whether the Systems Integrator wish to assume the defence in relation to such claim (including settlement or resolution thereof). Thereafter, the Systems Integrator shall be entitled in consultation with the Authority, and only to the extent such action does not in any manner compromise, prejudice or adversely affect the interests of the Authority, to take such action as mutually agreed upon by Systems Integrator and the Authority to avoid, dispute, deny, resist, appeal, compromise or consent such claim, within a period of 30 (thirty) days from the date of receipt of such claim notification;

- (iii) Notwithstanding anything contained herein, the Systems Integrator and the Authority agrees and covenant that a notice by the Authority to the Systems Integrator in relation to the claim as aforesaid shall amount to express acceptance and consent by the Systems Integrator to indemnify the Authority for all losses in relation to such claim. Upon notice by the System Integrator, the Authority shall reasonably co-operate with the Systems Integrator at the sole costs of the System Integrator, only to the extent the same does not in any manner compromise, prejudice or adversely affect the rights of the Authority. The Authority shall have the right, at its option, to participate in the defence of such claim;
  - (iv) The Authority shall, at the cost and expenses of the Systems Integrator, give the Systems Integrator reasonable assistance in the defence of such claim including reasonable access to all relevant information, documentation and personnel. The Systems Integrator shall bear cost and expenses and fees of the Attorney on behalf of the Authority in the litigation, claim.
- b) If the Systems Integrator fails to take any action as per the above clause within the time period as specified therein, the Authority shall have the right, in its absolute discretion, to take such action as it may deem necessary to avoid, dispute, deny, resist, appeal, compromise or contest or settle any claim (including without limitation, making claims or counterclaims against third parties). If the Systems Integrator does not assume full control over the defence of a claim as provided in this Clause, the entire defence, negotiation or settlement of such claim by the Authority shall be deemed to have been consented to by, and shall be binding upon, Systems Integrator as fully as though the Systems Integrator alone had assumed the defence thereof and a judgement had been entered into by the Systems Integrator, for such claim in respect of the settlement or judgement.
  - c) All settlements of claims subject to indemnification under this Article will: (a) be entered into only with the consent of the Authority, which consent will not be unreasonably withheld & include an unconditional release to the Authority from the claimant for all liability in respect of such claim; & (b) include any appropriate confidentiality agreement prohibiting disclosure of the terms of such settlement;
  - d) In the event that the Systems Integrator is obligated to indemnify the Authority pursuant to this Article, the Systems Integrator will, upon payment of such indemnity in full, be subrogated to all rights & defences of the Authority with respect to the claims to which such indemnification relates;
  - e) In the event that the Systems Integrator is obligated to indemnify the Authority pursuant to this Article, the Authority will be entitled to invoke the Performance Security, if such indemnity is not paid, either in full or in part, & on the invocation of the Security, the Systems Integrator shall be subrogated to all rights & defences of the Authority with respect to the claims to which such indemnification relates.

## **18.Publicity**

Except as required by law, Systems Integrator shall publish or permit to be published either alone or in conjunction with any other person any press release, information, article, photograph, illustration or any other material of whatever kind relating to this Agreement, the SLA without the explicit written permission of the Authority.

## **19.Representations**

### **19.Representations of the Systems Integrator**

The Systems Integrator warrants and represents to the Authority that:

- a) it is duly organized and validly existing under the laws of India and it has full capacity and authority and all necessary approvals to enter into and to perform its obligations under this Agreement and to carry out the transactions contemplated hereby;
- b) it has taken all necessary corporate and other actions under laws applicable to its business to authorize the execution and delivery of this Agreement and to validly exercise its rights and perform its obligations under this Agreement;
- c) it has the financial standing and capacity to undertake the Project and obligations in accordance with the terms of this Agreement;



- d) in providing the Services, it shall use reasonable endeavours not to cause any unnecessary disruption to Authority' normal business operations;
- e) This Agreement is executed by a duly authorized representative of the Systems Integrator and constitutes a legal, valid and binding obligation, enforceable against it in accordance with the terms hereof, and its obligations under this Agreement shall be legally valid, binding and enforceable against it in accordance with the terms hereof;
- f) the information furnished in the Proposal is to the best of its knowledge and belief true and accurate in all respects as at the date of this Agreement;
- g) the execution, delivery and performance of this Agreement shall not conflict with, result in the breach of, constitute a default by any of the terms of its Memorandum and Articles of Association or any Applicable Laws or any covenant, contract, agreement, arrangement, understanding, decree or order to which it is a party or by which it or any of its properties or assets is bound or affected;
- h) there are no material actions, suits, proceedings, or investigations pending or, to its knowledge, threatened against it at law or in equity before any court or before any other judicial, quasi-judicial or other authority, the outcome of which may result in the breach of this Agreement or which individually or in the aggregate may result in any material impairment of its ability to perform any of its material obligations under this Agreement;
- i) it has no knowledge of any violation or default with respect to any order, writ, injunction or decree of any court or any legally binding order of any Government Instrumentality which may result in any adverse effect on its ability to perform its obligations under this Agreement and no fact or circumstance exists which may give rise to such proceedings that would adversely affect the performance of its obligations under this Agreement;
- j) it has complied with Applicable Laws in all material respects and has not been subject to any fines, penalties, injunctive relief or any other civil or criminal liabilities which in the aggregate have or may have an adverse effect on its ability to perform its obligations under this Agreement;
- k) no sums, in cash or kind, have been paid or shall be paid, by it or on its behalf, to any person by way of fees, commission or otherwise for entering into this Agreement or for influencing or attempting to influence any officer or employee of Authority in connection therewith.
- l) The Systems Integrator is experienced in managing and providing works similar to the Services and that it will perform the Services with all due skill, care and diligence so as to comply with service level agreement;
- m) The Services will be provided and rendered by appropriately qualified, trained and experienced personnel as mentioned in the Tender;
- n) Systems Integrator has and will have all necessary licenses, approvals, consents of third Parties free from any encumbrances and all necessary technology, hardware and software to enable it to provide the Services;

## **20.Warranty**

### **20.1General**

The Systems Integrator represents, warrants and covenants that:

- a) the Systems Integrator is the lawful owner of the Goods (including those Goods and Deliverables that are to be transferred to Authority as per the RfP) and the lawful owner or licensee of the materials used in the performance of the Services and delivery of Deliverables,
- b) the bespoke development and such materials have been lawfully developed or acquired by the Systems Integrator , and
- c) the Systems Integrator has the right to sell the Goods to Authority and to grant Authority the rights to the bespoke development and such materials, including the rights of access to and use of the bespoke development, which it grants under this Agreement, without the consent of any other person or entity. The Systems Integrator represents warrants and covenants that during the Warranty Period it will promptly

provide Authority with any and all maintenance modifications, enhancements, and related documentation which the Systems Integrator or its OEM makes available to any other person or entity.

**20.2Warranty for Goods**

- a) Systems Integrator warrants that the Goods supplied under the Agreement and all of its parts and components are new, unused, of the most recent higher version /models and incorporate all recent improvements in design and materials unless provided otherwise in the Agreement.
- b) The Systems Integrator further warrants that the Goods supplied under this Agreement shall have no defects arising from design, materials or workmanship under normal use and that the Goods shall remain in good working order during the Warranty Period.
- c) The Systems Integrator shall provide a warranty as mentioned in this RfP (Warranty Period), for all the components, equipment, software and hardware manufactured, developed or supplied by it or any third party for the purpose of providing Services under "Service Level Agreement" as per the Agreement. The Systems Integrator shall ensure defect free operation of the entire solution and shall replace any such components, equipment, software and hardware which are found defective and during the entire Warranty Period the Systems Integrator shall apply all the latest upgrades/patches/releases for the software after appropriate testing. No additional costs shall be paid separately for the warranty other than what are the costs quoted by the Systems Integrator and as specified in the contract.
- d) That the Goods are and shall remain throughout the Warranty Period eligible for maintenance under the OEM's standard maintenance agreement.
- e) If the Systems Integrator uses in the course of the provision of the Services, components, equipment, software and hardware manufactured by any third party and which are embedded in the Deliverables or are essential for the successful use of the Deliverables, it will pass through third party manufacturer's Warranties relating to those components, equipment, software and hardware to the extent possible.
- f) The overall system design shall be such that there is no choking point / bottleneck anywhere in the system (end-to-end) which can affect the performance / SLAs.
- g) That Systems Integrator shall acquire good and clear title on the Goods, free and clear of any and all charges and encumbrances and shall have right to uninterrupted use of such Goods;

**20.3Warranties for Software**

- a) The Systems Integrator represents warrants and covenants that on the acceptance date and for the Warranty Period, the Software will be free of material programming errors and will operate and conform to the respective Software's Documentation including, inter alia, SRS (System Requirement Specification) and other manuals. The Systems Integrator also represents warrants and covenants that the medium on which the Software is contained when delivered to Authority will be free from defects in material or workmanship and shall be free from any viruses, bugs etc.
- b) The Systems Integrator represents warrants and covenants that the technical Documentation delivered to Authority for the system will be sufficient to allow a reasonably knowledgeable information technology professional to maintain and support such Software. The Systems Integrator represents warrants and covenants that the user Documentation for the System will accurately describe in terms understandable by a typical end user the functions and features of the System and the procedures for exercising such functions and features.

**20.4Warranty for Services**

The Systems Integrator represents, warrants and covenants that all services under this Agreement will be performed with promptness and diligence and will be executed in a workmanlike and professional manner, in accordance with the practices and high professional standards used in well-managed operations performing services similar to the services under this Agreement. The Systems Integrator represents, warrants and covenants that it shall use adequate numbers of qualified individuals with suitable training, education, experience and skill to perform the services hereunder.

**20.5f** during the Warranty Period of any component mentioned above, any of the warranties are found breached, the Systems Integrator shall promptly (but in no event more than 7(seven) days, in consultation and agreement with Authority, and at the Systems Integrator's sole cost repair, replace, or otherwise make good such default, defect or deficiency as well as any damage to the Project caused by such default, defect or deficiency. Any component that has been repaired or replaced by the Systems Integrator shall be delivered at the Authority's designated place without any additional costs to the Authority. Any component that has been replaced under this clause by the Systems Integrator shall remain the property of the Systems Integrator. The Systems Integrator shall use best efforts to ensure that such repair, replacement etc. shall be accomplished through a "hot" swap without any loss of production time or adverse impact on Authority's or System's operations. If the System cannot be used by reason of such default, defect or deficiency and/or making good of such default, defect or deficiency, the warranty period for the System shall be extended by a period equal to the period during which the System or any of its components could not be used by Authority because of such defect and/or making good of such default, defect or deficiency. Notwithstanding the foregoing, these are not the sole and exclusive remedies available to Authority in case of breach of any warranty and are also not the sole and exclusive obligations on the Systems Integrator in case of breach of any warranty.

Further, subject to the fulfilment of the obligations of the Systems Integrator as provided hereinabove, in the event that such warranties cannot be enforced by Authority, the Systems Integrator will enforce such warranties on behalf of Authority and pass on to Authority, the benefit of any other remedy received in relation to such warranties.

**20.6** Notwithstanding what has been stated elsewhere in this Agreement and the Schedules attached herein, in the event the Systems Integrator is unable to meet the obligations pursuant to the implementation of the Project, Operations and Maintenance Services and any related scope of work as stated in this Agreement and the Schedules attached herein, Authority will have the option to invoke the Performance Security after serving a written notice of thirty (30) days on the Systems Integrator.

## **21. Force Majeure**

**21.1** The Systems Integrator shall not be liable for forfeiture of its Performance Security, imposition of liquidated damages or termination for default, if and to the extent that its delay in performance or other failure to perform its obligations under the contract is the result of an event of Force Majeure. For purposes of this Clause, "Force Majeure" means an event beyond the "reasonable" control of the System Integrator, not involving the System Integrator's fault or failure to perform its obligations under the Agreement or negligence and not foreseeable or an event which the Systems Integrator could not have prevented or reasonably overcome with the exercise of reasonable skill and care. Such events may include Acts of God & acts of Government of India in their sovereign capacity that directly and adversely affect the performance of services by the Systems Integrator under this Agreement.

**21.2** For the Systems Integrator to take benefit of this clause it is a condition precedent that the Systems Integrator must notify the Authority, in writing of such conditions and the cause thereof within 2 (two) calendar days of the Force Majeure event arising. Authority, or the consultant / committee appointed by the Authority shall study the submission of the Systems Integrator and inform whether the situation can be qualified one of Force Majeure. If the other Party disputes the claim for relief under Force Majeure it shall give the claiming Party written notice of such dispute within 30 (thirty) days of such notice. Such dispute shall be dealt with in accordance with the dispute resolution mechanism in accordance with Clause. Unless otherwise directed by the Authority in writing, the Systems Integrator shall continue to perform its obligations under the

resultant Agreement as far as it is reasonably practical, and shall seek all reasonable alternative means for performance of services not prevented by the existence of a Force Majeure event.

**21.3** Upon cessation of the situation which led the Systems Integrator claiming Force Majeure, the Systems Integrator shall within 2 (two) days thereof notify Authority in writing of the cessation and the Parties shall as soon as practicable thereafter continue performance of all obligations under this Agreement.

**21.4** In the event of delay in performance attributable to the presence of a Force Majeure event, Authority reserves the right to extend the time for performance shall by a period(s) equivalent to the duration of such delay. If the duration of delay continues beyond a period of 30 (thirty) days, Authority and the Systems Integrator shall hold consultations with each other in an endeavour to find a solution to the problem to determine the reasonable measures to be implemented to minimize the losses of each Party resulting from the Force Majeure event. Systems Integrator at its own cost, take all steps reasonably required to remedy and mitigate the effects of the Force Majeure event and restore its ability to perform its obligations under this Agreement as soon as reasonably practicable.

**21.5** Notwithstanding anything to the contrary mentioned above, the decision of the Authority shall be final and binding on the System Integrator.

## **22. Resolution of Disputes**

**22.1** The Authority and the Systems Integrator shall make every effort to resolve amicably, by direct informal negotiation, any disagreement or dispute arising between them under or in connection with the Agreement. If after 30 (thirty) days from the commencement of such informal negotiations, the Authority and the Systems Integrator are unable to resolve amicably such dispute, the matter will be referred to the Chief Secretary, Government of Kerala, and his / her opinion shall be taken.

**22.2** If the Systems Integrator doesn't agree with the opinion of the Chief Secretary, Government of Kerala, the matter shall be referred to a panel of three Arbitrators: one Arbitrator to be nominated by Authority, the other one to be nominated by the Systems Integrator and a third arbitrator to be appointed by the two arbitrators jointly. The award of the majority of the Arbitrators shall be final and binding on the parties. Proceedings under this clause shall be subject to applicable law of the Arbitration and Reconciliation Act, 1996 and the venue of such arbitration shall be Thiruvananthapuram. Cost of arbitration shall be borne by each party proportionately. However, expenses incurred by each party in connection with the preparation, presentation shall be borne by the party itself. The provisions of this clause shall survive termination of this Agreement.

## **23. Risk Purchase Clause**

In the event Systems Integrator fails to execute the Project as stipulated in the delivery schedule, or to the satisfaction of the Authority or fails to perform its obligations (or any part thereof) under this Agreement or if the Agreement is terminated by the Authority due to breach of any obligations of the Systems Integrator under this Agreement, Authority reserves the right to procure similar or equivalent services/Deliverables from the next eligible Bidder or from another alternate source at the risk, cost and responsibility of the System Integrator. Any incremental cost borne by the Authority in procuring such services/ Deliverables shall be borne by the System Integrator. Any such incremental cost incurred in the procurement of the such services/ Deliverables from alternative source will be recovered from the undisputed pending due and payable payments /Security Deposit provided by the Systems Integrator under this Agreement and if the value of the services/Deliverables under risk purchase exceeds the amount of Security Deposit, the same may be recovered if necessary by due legal process. Before taking such a decision under this Clause, Authority shall serve a notice period of 1(one) month to the System Integrator.

## **24. Limitation of Liability towards Authority**

**24.1** The Systems Integrator's liability under the Agreement shall be determined as per the Applicable Law in force for the time being. The Systems Integrator shall be liable to the Authority for loss or damage occurred or caused or likely to occur on account of any act of omission on the part of the Systems Integrator and its employees, including loss caused to Authority on account of defect in Goods or deficiency in Services on the part of Systems Integrator or its agents or any person / persons claiming through or under said Systems

Integrator. However, such liability of Systems Integrator shall not exceed 100% of the total value of the Agreement.

**24.2** Except as otherwise provided herein, in no event shall either party be liable for any consequential, incidental, indirect, special or punitive damage, loss or expenses (including but not limited to business interruption, lost business, lost profits, or lost savings) nor for any third party claims, even if it has been advised of their possible existence.

**24.3** This limitation of liability provided in Clause 24.1 and Clause 24.2 shall not limit the Systems Integrator's liability for the indemnity obligations of the Systems Integrator as agreed in this Agreement.

## **25.Data Ownership**

All the data created as the part of the project shall be owned by Authority. The Systems Integrator shall take utmost care in maintaining security, confidentiality, integrity and backup of this data. Access to the data / systems shall be given by the Systems Integrator strictly only to the personnel working on the projects who have a need to know such data for accomplishing the Project and who are bound by obligations of confidentiality no less restrictive as provided in this Agreement and their names & contact details shall be shared with Authority in advance. Authority / its authorized representative(s) shall conduct periodic / surprise security reviews and audits, to ensure the compliance by the Systems Integrator to data / system security.

## **26.Conflict of Interest**

**26.1** A conflict of interest is any situation that might cause an impartial observer to reasonably question whether Systems Integrator actions are influenced by considerations of your firm's interest at the cost of Government.

**26.2** The Systems Integrator shall disclose to the Authority in writing, all actual and potential conflicts of interest that exist, arise or may arise (either for the Systems Integrator or its team) in the course of performing the Services as soon as it becomes aware of such a conflict. However, the Systems Integrator shall hold Authority's interest paramount, without any consideration for future work, and strictly avoid conflict of interest with other assignments

## **27.Fraud and Corruption**

Authority requires that SI must observe the highest standards of ethics during the execution of the contract. In pursuance of this policy, Authority defines, for the purpose of this provision, the terms set forth as follows:

- a) "Corrupt practice" means the offering, giving, receiving or soliciting of anything of value to influence the action of Authority in contract executions.
- b) "Fraudulent practice" means a mis-presentation of facts, in order to influence a procurement process or the execution of a contract Authority, and includes collusive practice among bidders (prior to or after Proposal submission) designed to establish Proposal prices at artificially high or non-competitive levels and to deprive Authority of the benefits of free and open competition.
- c) "Unfair trade practices" means supply of services different from what is ordered on, or change in the Scope of Work which is given by the Authority in Volume II.
- d) "Coercive Practices" means harming or threatening to harm, directly or indirectly, persons or their property to influence their participation in the execution of contract.

If it is noticed that the SI has indulged into the Corrupt / Fraudulent / Unfair / Coercive practices, it will be a sufficient ground for Government for termination of the contract and initiate black-listing of the SI.

## **28.Exit Management**

### **28.Exit Management Purpose**

This clause sets out the provisions, which will apply during Exit Management period. The Parties shall ensure that their respective associated entities carry out their respective obligations set out in this Exit Management Clause.

The exit management period starts, in case of expiry of contract, at least 6(six) months prior to the expiry of the Term of the Agreement or in case of termination of Agreement, on the effective date of termination of the Agreement. In

the case of termination of any part of the Agreement or Services, the provisions of this Clause shall, mutatis mutandis, apply to the part of Agreement or Services terminated. The exit management period ends on the date agreed upon by the Authority or Six months after the beginning of the exit management period, whichever is earlier.

### **28.3 Confidential Information, Security and Data**

Systems Integrator will promptly on the commencement of the exit management period, supply to the Authority or its nominated agencies the following:

- a) Information relating to the current services rendered and performance data relating to the performance of the services; Documentation relating to Project, Project's Intellectual Property Rights; any other data and confidential information related to the Project including but not limited to documentation relating to sub-contractors;
- b) All current and updated Project data as is reasonably required for purposes of the Project or for transitioning of the services to its Replacing Systems Integrator in a readily available format.
- c) All other information (including but not limited to documents, records and agreements) relating to the services reasonably necessary to enable the Authority and its nominated agencies, or its Replacing Systems Integrator to carry out due diligence in order to transition the provision of the Services to Authority, or its Replacing Systems Integrator (as the case may be).
- d) Before the expiry of the exit management period, the Systems Integrator shall deliver to the Authority or its nominated agency all new or up-dated materials from the categories set out above (or any other information and data requested by the Authority) and shall not retain any copies thereof, except that the Systems Integrator may be permitted to retain one copy of such materials for archival purposes only as approved by the Authority.
- e) On completion of the exit management period, the Systems Integrator shall delete all confidential information and data from the System Integrator's system and provide a certificate to the Authority stating the completion of deletion of all such data and information.

### **28.3 Employees**

Promptly on reasonable request at any time during the exit management period, the Systems Integrator shall, subject to applicable laws, restraints and regulations (including in particular those relating to privacy) provide to the Authority a list of all employees (with job titles and communication address) of the System Integrator, dedicated to providing the services at the commencement of the exit management period; To the extent that any Transfer Regulation does not apply to any employee of the System Integrator, Authority or Replacing Systems Integrator may make an offer of contract for services to such employee of the Systems Integrator and the Systems Integrator shall not enforce or impose any contractual provision that would prevent any such employee from being hired by the Authority or any Replacing System Integrator.

### **28.4 Cooperation And Provision Of Information**

- (i) During the exit management period:
  - a) The Systems Integrator will allow the Authority or its nominated agency access to information reasonably required to define the then current mode of operation associated with the provision of the Services to enable the Authority to assess the existing services being delivered;
  - b) The System Integrator, on reasonable request by the Authority, shall promptly provide access to and copies (hard and soft copies as deemed necessary by the Authority) of all information held or controlled by the Systems Integrator which it has prepared or maintained in accordance with this Agreement relating to any material aspect of the Services (whether provided by the previous System Integrator, the Systems Integrator or sub-contractors appointed by the System Integrator). The Authority shall be entitled to copy of all such information. Such information shall include details pertaining to the services rendered and other performance data. The Systems Integrator shall permit the Authority and/or its nominated agencies to have reasonable access to the employees engaged for providing services and facilities as reasonably required by the Authority to understand the methods of delivery of the services employed by the Systems Integrator and to assist appropriate knowledge transfer.

- c) During the exit management period, the Replacing Systems Integrator shall submit periodic reports on the progress of the transition with the Authority and the System Integrator. The Systems Integrator shall ensure that any issues and gaps highlighted in such reports shall be resolved to the satisfaction of the Authority.

(ii) Transfer of Certain Agreements

On request by the Authority or its nominated agency the Systems Integrator shall effect such assignments, transfers, licences and sub-licences as the Authority may require in favour of the Authority or its nominated agencies or its Replacing Systems Integrator in relation to any equipment lease, maintenance or service provision agreement between the Systems Integrator and third party lessors, System Integrators, and which are related to the services and reasonably necessary for the carrying out of replacement services by the Authority or its nominated agency or its Replacing System Integrator.

(iii) Rights of Access to Information

At any time during the exit management period, the Systems Integrator will be obliged to provide an access of information to Authority and / or any Replacing Systems Integrator in order to make an inventory of the Assets (including hardware / Software / Active / passive), documentations, manuals, catalogues, archive data, Live data, policy documents or any other material related to the Project.

(iv) Rights of Access To Premises

- a) At any time during the exit management period, where Assets are located at the System Integrator's premises, the Systems Integrator will be obliged to give reasonable rights of access to (or, in the case of Assets located on a third party's premises, procure reasonable rights of access to) the Authority or its nominated agency and/or any Replacing Systems Integrator in order to make an inventory of the Assets.
- b) The Systems Integrator shall also give the Authority or its nominated agency or its nominated agencies, or any Replacing Systems Integrator right of reasonable access to the System Integrator's premises and shall procure the Authority or its nominated agency or its nominated agencies and any Replacing Systems Integrator rights of access to relevant third party premises during the exit management period and for such period of time following termination or expiry of the Agreement as is reasonably necessary to migrate the services to the Authority or its nominated agency, or a Replacing Systems Integrator.

(v) General Obligations Of The SI

- a) The Systems Integrator shall provide all such information as may reasonably be necessary to effect as seamless handover as practicable in the circumstances to the Authority or its nominated agency or its Replacing Systems Integrator and which the Systems Integrator has in its possession or control at any time during the exit management period.
- b) For the purposes of this Schedule, anything in the possession or control of any System Integrator, associated entity, or sub-contractor is deemed to be in the possession or control of the System Integrator.
- c) The Systems Integrator shall commit adequate resources to comply with its obligations under the Exit Management Schedule.

## 29. Termination of Contract

### 29. Events of Default by the Systems Integrator

- a) The failure of the Systems Integrator to perform any of the obligations or comply with any terms of this Agreement shall constitute an Event of Default on the part of the System Integrator. The events of default as mentioned above may include, inter-alia, the following:
- If the Systems Integrator fails to deliver any or all of the project requirements / operationalization / go-live of the project within the time frame specified in the contract; or

- If the Systems Integrator fails to perform any other obligation(s) under the Agreement fails to perform any instructions or directives issued by the Authority which it deems proper and necessary to execute the scope of work under the Agreement.
  - the Systems Integrator has failed to remedy a failure to perform its obligations in accordance with the specifications issued by the Authority, despite being served with a default notice which laid down the specific deviance on the part of the Systems Integrator to comply with any stipulations or standards as laid down by the Authority; or
  - the Systems Integrator or its team has failed to conform with any of the service specifications as set out in the RfP or this Agreement or has failed to adhere to any amended direction, modification or clarification as issued by the Authority during the term of this Agreement and which the Authority deems proper and necessary for the execution of the scope of work under this Agreement;
  - the Systems Integrator has failed to demonstrate or sustain any representation or warranty made by it in this Agreement, with respect to any of the terms of its Proposal, the RfP and this Agreement;
  - There is a proceeding for bankruptcy, insolvency, winding up or there is an appointment of receiver, liquidator, assignee, or similar official against or in relation to the System Integrator;
  - The Systems Integrator or its team has failed to comply with or is in breach or contravention of any Applicable Laws;
  - The Systems Integrator has failed to comply with any terms and conditions of the this Agreement;
  - Undue delay in achieving the agreed timelines for delivering the services under this Agreement;
  - Quality of Deliverables and services consistently not being to the satisfaction of the Authority.
- b) The Authority shall have the right to terminate the contract in whole or in part at any time for its convenience by giving 30 days prior written notice. The notice of termination shall specify that termination is for the Authority's convenience, the extent to which performance of work under the contract is terminated and the date upon which such termination becomes effective.
- c) Where there has been an occurrence of such Event of Default , inter alia as stated above, Authority shall provide the Systems Integrator with a written notice of 30 (thirty) days setting out specific defaults / deviances / omissions and instructing the Systems Integrator to cure any breach/ default of the Contract, if Authority is of the view that the breach may be rectified
- d) Where despite the issuance of a default notice to the Systems Integrator by the Authority the Systems Integrator fails to remedy the default to the satisfaction of the Authority, the Authority may, where it deems fit, issue to the Systems Integrator another default notice or proceed to adopt such remedies as may be available to the Authority including but not limited to the remedies provided herein below.

## **29. Consequences for Events of Default**

Where an Event of Default sub-contractors or remains uncured, the Authority shall be entitled to:

- a) Impose any such obligations and conditions and issue any clarifications as may be necessary to, inter alia, ensure smooth continuation of the Services and the project which the Systems Integrator shall be obliged to comply with, which may include unilateral re-determination of the consideration payable to the Systems Integrator under this Agreement. The Systems Integrator shall in addition take all available steps to minimize loss resulting from such event of default.
- b) Suspend all payments to the Systems Integrator under the Agreement by written notice of suspension to the Systems Integrator provided that such notice of suspension shall (a) specify the nature of failure; and (b) request the Systems Integrator to remedy such failure within a specified period from the date of receipt of such notice of suspension by the System Integrator
- c) Where the Authority deems it necessary, it shall have the right to require replacement of any of the sub-contractors with another suitable sub-contractor. The sub-contractor/ Systems Integrator shall in such case terminate forthwith all their agreements/contracts, other arrangements with such sub-contractor and find out the suitable replacement for such outgoing sub-contractor with another sub-contractor to the satisfaction of the Authority, who shall execute such contracts with the Authority as the Authority may require. Failure on the part of the Systems Integrator to find a suitable replacement and/or terminate all agreements/contracts with such member, shall amount to a breach of the terms hereof and the Authority in addition to all other rights, have the right to claim damages and recover from the Systems Integrator all losses/ or other damages that may have resulted from such failure.
- d) Terminate this Agreement in full or in part.



- e) Retain such amounts from the payment due and payable by the Authority to the Systems Integrator as may be required to offset any losses caused to the Authority as a result of such event of default and the Systems Integrator shall compensate the Authority for any such loss, damages or other costs, incurred by the Authority in this regard. Nothing herein shall effect the continued obligation of the sub-contractor / other members of its Team to perform all their obligations and responsibilities under this Agreement in an identical manner as were being performed before the occurrence of the default.
- f) Invoke the Security Deposit and other Guarantees furnished hereunder, enforce indemnity provisions, recover such other costs/losses and other amounts from the Systems Integrator may have resulted from such default and pursue such other rights and/or remedies that may be available to the Authority under law.

### **29.3 Termination for Breach**

The Authority may, terminate this Agreement by giving the Systems Integrator a prior and written notice of up to 30 days indicating its intention to terminate the Agreement under the following circumstances:

- a) Where the Authority is of the opinion that there has been such Event of Default on the part of the Systems Integrator which would make it proper and necessary to terminate this Agreement and may include failure on the part of the Systems Integrator to respect any of its commitments with regard to any part of its obligations under its Proposal, the RfP or under this Agreement.
- b) Where it comes to the Authority's attention that the Systems Integrator (or the System Integrator's Team) is in a position of actual conflict of interest with the interests of the Authority, in relation to any of terms of the Systems Integrator's Proposal, the RfP or this Agreement.
- c) Authority may terminate this Agreement due to reason specified in clause 6.3
- d) Authority may terminate the Agreement if it comes to knowledge of the Authority that the Systems Integrator or any of the System Integrator's personnel or the System Integrator's sub-contractors or such sub-contractor's personnel have been involved in any fraudulent or corrupt practices or any other practice of similar nature.

### **29.4 Termination for Convenience**

The Authority, may, by written notice of 60 (sixty) days sent to the Vendor, terminate the Agreement, in whole or in part at any time for its convenience. The notice of termination shall specify that termination is for the Authority's convenience, the extent to which performance of work under the Agreement is terminated, and the date upon which such termination becomes effective.

### **29.5 Consequences of Termination**

- a) In the event of termination of this contract, Authority is entitled to impose any such obligations and conditions and issue any clarifications as may be necessary to ensure an efficient transition and effective continuity of the services which the SI shall be obliged to comply with and take all available steps to minimize the loss resulting from that termination/ breach, and further allow and provide all such assistance Authority and/ or succeeding SI, as may be required, to take over the obligations of the SI in relation to the execution / continued execution of the requirements of this Agreement.
- b) In the event that the termination of this Agreement is due to the expiry of the Term of this Agreement / a decision not to grant any (further) extension by the Authority, or where the termination is prior to the expiry of the stipulated term due to the occurrence of any Event of Default on the part of the System Integrator, the Systems Integrator herein shall be obliged to provide all such assistance to the successor Systems Integrator or any other person as may be required and as the Authority may specify including training, where the successor(s) is a representative/personnel of the Authority to enable the successor to adequately provide the Services hereunder, even where such assistance is required to be rendered for a reasonable period that may extend beyond the Term/earlier termination hereof. Without prejudice to the foregoing, upon termination (or upon expiry of the Term) of this Agreement, the Parties will comply with the Exit Management Schedule/ Plan.
- c) Where the termination of the Agreement is prior to its stipulated term on account of an Event of Default on the part of the Systems Integrator or due to the fact that the survival of the Systems Integrator as an independent corporate entity is threatened/has ceased, the Authority shall pay the Systems Integrator for that part of the Services which have been authorized by the Authority and satisfactorily performed by the Systems

Integrator up to the date of termination. Without prejudice any other rights, the Authority may retain such amounts from the payment due and payable by the Authority to the Systems Integrator as may be required to offset any losses caused to the Authority as a result of any act/omissions of the System Integrator. In case of any loss or damage due to default on the part of the Systems Integrator in performing any of its obligations with regard to executing the scope of work under this Agreement, the Systems Integrator shall compensate the Authority for any such loss, damages or other costs, incurred by the Authority. Additionally, the sub-contractor / other members of its team shall perform all its obligations and responsibilities under this Agreement in an identical manner as were being performed before the collapse of the Systems Integrator as described above in order to execute an effective transition and to maintain business continuity. All third parties shall continue to perform all/any functions as stipulated by the Authority and as may be proper and necessary to execute the scope of work under the Agreement in terms of the System Integrator's Proposal, the RfP and this Agreement.

- d) Nothing herein shall restrict the right of the Authority to invoke the Performance Security and other Guarantees furnished hereunder and pursue such other rights and/or remedies that may be available to the Authority under law.
- e) Any and all payments under this clause shall be payable only after the Systems Integrator has complied with and completed the transition and exit management as per the Exit Management Plan to the satisfaction of the Authority. In case of expiry of the Agreement, the last due payment shall be payable to the Systems Integrator after the Systems Integrator has complied with and completed the transition and exit management as per the Exit Management Plan to the satisfaction of the Authority.
- f) All plans, drawings, specifications, designs, reports and other documents prepared by the SI in the execution of the Agreement shall become and remain the property of Authority and before termination or expiration of this Agreement the Systems Integrator shall deliver all such documents, prepared under this Agreement along with a detailed inventory thereof, to Authority. All rights, title, interest and ownership of all Goods and Deliverables provided by the SI to the Authority shall be deemed to be transferred to the Authority without any further action required for such transfer.

### **29. Termination of Agreement due to bankruptcy of the Systems Integrator**

Where the Systems Integrator's ability to survive as an independent corporate entity is threatened or is lost owing to any reason whatsoever, including inter-alia the filing of any bankruptcy proceedings against the Systems Integrator, any failure by the Systems Integrator to pay any of its dues to its creditors, the institution of any winding up proceedings against the Systems Integrator or the happening of any such events that are adverse to the commercial viability of the Systems Integrator, the Authority shall reserve the right to take any steps as may be necessary, to ensure the effective transition of the project to a successor Systems Integrator, and to ensure business continuity provided that such termination will not prejudice or affect any right of action or remedy which has accrued or will accrue thereafter to the Authority.

### **29. Rights other than Termination**

The termination hereof shall not affect any accrued right or liability of either Party nor affect the operation of the provisions of this Agreement that are expressly or by implication intended to come into or continue in force on or after such termination. The termination provisions set out in this Clause are in addition to any termination rights that the Authority may have under this Agreement/RfP and are in addition to, and without prejudice to, other rights that the Authority may have under law and this Agreement.

### **30. AUDIT, ACCESS AND REPORTING**

The Systems Integrator shall allow access to Authority or its nominated agencies to all information which is in the possession or control of the Systems Integrator or its sub-contractors, agents, suppliers etc. and which relates to the provision of the Services/Deliverables as set out in the Audit, Access and Reporting Schedule and which is reasonably required by Authority to comply with the terms of the Audit, Access and Reporting Schedule set out as Schedule I of this Agreement.

### **31. Miscellaneous**

#### **31. Confidentiality**

- i. "Confidential Information" means all information including Project Data (whether in written, oral, electronic or other format) which relates to the technical, financial and operational affairs, business rules, citizen information, video footages, alert information, any Authority data, products, processes, data, crime / criminal secrets, design rights, know-how and personnel of each Party which is disclosed to or otherwise learned by the other Party or its consortium partners or sub-contractors (whether a Party to the contract or to the SLA) in the course of or in connection with the Agreement (including without limitation such information received during negotiations, location visits and meetings in connection with the Agreement or to the SLA) or pursuant to the contract to be signed subsequently.
- ii. The Systems Integrator recognizes that during the Term of the Agreement, Confidential Information and sensitive data will be procured & made available to it, its sub-contractors & agents & others working for or under the System Integrator. Additionally, the Systems Integrator shall keep confidential all the details and information with regard to the Project, including systems, facilities, operations, management and maintenance of the systems/facilities. The Systems Integrator shall use the information only to execute the Project. Disclosure or usage of such data by any such recipient may constitute a breach of law applicable causing harm not only to the Authority whose data is used but also to its stakeholders. The function of Authority requires the System Integrator, its sub-contractors & agents to demonstrate utmost care, sensitivity & strict confidentiality. The Authority shall retain all rights to prevent, stop and if required take the necessary punitive action against the Systems Integrator regarding any forbidden disclosure. Any breach of this Clause will result in irreparable loss to the Authority and the Authority reserves the right to seek injunctive relief & damages from the System Integrator. Such remedies shall not be deemed to be the exclusive remedies for a breach by a Party of this clause, but shall be in addition to all other remedies available at law or equity to the damaged Party.
- iii. The Systems Integrator shall execute a corporate non-disclosure agreement with Authority in the format provided by the Authority and shall ensure that all its employees, agents and sub-contractors execute individual non-disclosure agreements, which have been duly approved by the Authority with respect to this Project.
- iv. Systems Integrator agrees as to any Confidential Information disclosed by Authority (the "Discloser") to the Systems Integrator under this Agreement (the "Recipient")
  - a. to take such steps necessary to protect the Discloser's Confidential information from unauthorized use, reproduction & disclosure, as the Recipient takes in relation to its own Confidential Information of the same type, but in no event less than reasonable care;
  - b. not to disclose such Confidential Information to any person except who have a need to know such Confidential Information to carry out the Services under this Agreement and who are bound by obligations of confidentiality no less restrictive as provided in this Agreement;
  - c. to use such Confidential Information only for the purposes of this Agreement or as otherwise expressly permitted or expressly required by this Agreement or as otherwise permitted by the Discloser in writing;
  - d. Not, without the Discloser's prior written consent, to copy the Confidential Information cause or allow it to be copied, directly or indirectly, in whole or in part, except as otherwise expressly provided in this Agreement, or as required in connection with Recipient's use as permitted under this Article, or as needed for the purposes of this Agreement, or as needed for the purposes of this Agreement, provided that any proprietary legends & notices (whether of the Discloser or of a Third Party) are not removed or obscured;
  - e. Not, to disclose, transfer, publish or communicate the Confidential Information in any manner, without the Discloser's prior written consent, to any person except as permitted under this Agreement.
- v. The restrictions of this section shall not apply to confidential Information that:

- a. Is or becomes generally available to the public through no breach of this Article by the Recipient;
  - b. Was in the lawfully and demonstrably in Recipient's possession free of any obligation of confidence prior to the time of receipt of it by the Recipient hereunder;
  - c. Is developed by the Recipient independently of any of discloser's Confidential Information;
  - d. Is rightfully obtained by the Recipient from third Parties authorized at that time to make such disclosure without restriction;
  - e. Is identified in writing by the Discloser as no longer proprietary or confidential;
  - f. Is required to be disclosed by law, regulation or Court Order, provided that the Recipient gives prompt written notice to the Discloser of such legal & regulatory requirement to disclose so as to allow the Discloser reasonable opportunity to contest such disclosure
- vi. To the extent that such disclosure is required for the purposes of this Agreement, Recipient may disclose Confidential Information to:
- a. Its employees, agents & independent SIs & to any of its affiliates & their respective independent SIs or employees in order to carry out the Services under this Agreement;
  - b. Its professional advisors & auditors, who require access for the purposes of this Agreement, whom the Recipient has informed of its obligations under this Clause & Recipient has used commercially reasonable efforts to ensure that they are contractually obliged to keep such Confidential Information confidential on terms substantially the same as set forth in this Article. Either Party may also disclose confidential Information or any entity with the other Party's prior written consent.
- vii. The provisions of this Clause shall survive the expiration or any earlier termination of this Agreement.
- viii. Confidential Information shall be & remain the property of the Discloser & nothing in this Clause shall be construed to grant either Party any right or license with respect to the other Party's confidential Information otherwise than as is expressly set out in this Agreement,
- ix. Subject as otherwise expressly provided in this Agreement all Confidential information in tangible or electronic form under the control of the Recipient shall either be destroyed, erased or returned to the Discloser promptly upon the earlier of: (i) the written request of the Discloser, or, (ii) termination or expiry of this Agreement and the Recipient shall provide a signed declaration by its authorized representative in this regard confirming compliance with this Clause. Notwithstanding the forgoing, both Parties may retain, subject to the terms of this Article, reasonable number of copies of the other Party's Confidential Information solely for confirmation of compliance with the confidentiality obligations of this Agreement.
- x. Neither Party is restricted by the provisions of this Clause from using (including using to provide products or perform services on behalf of third Parties) any ideas, concepts, know-how & techniques that are related to the Recipient's employees or agents (and not intentionally memorized for the purpose of later recording or use) (collectively, the "Residuals"). This Clause shall not permit the disclosure or use by either Party or any financial (including business plans), statistical, product, personnel or customer data or the other Party. Each party agrees not to disclose the source of the Residuals.

### **31. Delegation of Authority**

The Authority may delegate any office functions / authority to any other competent person or his subordinate official or supervision consultant as the Authority think appropriate for effective administration of the Agreement. However these delegations will not diminish the overall authority of the Authority. The Authority can review the delegations

so made at any time. The delegation of function/authority by the Authority shall be intimated to the Applicant in writing.

The SI shall designate and authorize a representative to deal with the Authority, Engineer and Engineer's Representative. The name of the Applicant's representative shall be notified by the Applicant to the Authority in writing.

### **31. Sub Contracts**

#### **Constitution of consortium**

- i. For the purposes of fulfilment of its obligations as laid down under the Agreement, unless the context requires otherwise, SI shall be the sole point of interface between the Authority and the SI and the SI would be absolutely accountable for the performance of its own, the other members of Consortium and / or its Team's functions and obligations.
- ii. The Consortium Members agree that the SI shall be the prime point of contact between the Consortium Members and the Authority and shall be primarily responsible for the discharge and administration of all the obligations contained herein and, the Authority, unless it deems necessary shall deal only with the SI.
- iii. SI shall not, except with the prior approval of the Authority, have any provision in the consortium agreement or make any amendments to the said consortium agreement which adversely affects the rights and/or obligations of SI and Consortium Members under this Agreement or any amendment which is contrary to the provisions of this Agreement.
- iv. The SI shall be liable for all obligations under this Agreement. The Lead Bidder shall ensure that at all times during the Term of this Agreement, Consortium Member and the Consortium Member's Team complies with all the terms and conditions of this Agreement.
- v. The SI and the Consortium Member shall be bound by all undertakings and representations made by their authorized representative and any covenants stipulated hereunder with respect to this Agreement, for and their behalf. The terms and conditions of this Agreement shall mutatis mutandis apply to all Consortium Members.
- vi. The SI shall not change any Consortium Member without the prior written approval of the Authority. The approval of the Authority may be subject to certain conditions in terms of credentials and qualifications of the new Consortium Member which the SI shall be liable to meet. The SI shall give a notice of at least 4 months in advance to the Authority if during the term of this Agreement the SI desires to terminate any contract/arrangement relating to the performance of Services hereunder with the Consortium Member. Where, during the term of this Agreement, the SI terminates any contract/arrangement or agreement relating to the performance of the Services hereunder with any Consortium Member (subject to approval by the Authority), the SI shall be liable for any consequences resulting from such termination. The SI shall in such case ensure the smooth continuation of Services by providing a suitable replacement subject to approval and to the satisfaction of the Authority at no additional charge and at the earliest opportunity.
- vii. All the personnel working on the Project and having access to the Servers / data should be on payroll of the Systems Integrator. Sub-contracting / out sourcing would be allowed only for work like
  - Passive Networking & Civil Work during implementation,
  - Viewing Manpower at NOC during post-implementation
  - Field staff during post-implementation

- viii. The Systems Integrator shall provide details of the sub-contractors for the work which is allowed as mentioned in the Clause. Use of personnel not on payroll of the Systems Integrator shall be considered as sub-contracting.
- ix. The Systems Integrator shall take prior approval from Authority for sub-contracting any allowed work as mentioned in clause, if not already specified in the proposal and approved by Authority. Such sub-contracting shall not relieve the Systems Integrator from any liability or obligation under the Agreement. The Systems Integrator shall solely responsible for the work carried out by subcontracting under the Agreement. It is clarified that the Systems Integrator shall be the principal employer for all claims arising from the liabilities statutory or otherwise, concerning the sub-contractors.
- x. Save as provided in Sub- Clause (iii) above, the Systems Integrator shall immediately upon execution of the contract(s) to be entered into with such sub-contractor provide a copy of the same (without commercials) to the Authority within 15(fifteen) days from the date of signing the Agreement and shall not review, amend, modify or terminate the terms of such contracts without the prior written consent of the Authority.
- xi. Prior to executing any contract or entering into any contract or understanding with a delegate/sub-contractor, the Systems Integrator shall ensure that each sub-contractor appointed by the Systems Integrator executes a Deed of Adherence, a performance Undertaking and non-disclosure agreements in the manner and form prescribed by the Authority. A copy of the detailed executed agreement with prices blanked shall be submitted to the Authority within 15 (fifteen) days from the date of signing the Agreement.
- xii. The Systems Integrator shall ensure that the sub-contractor appointed is competent and professional and possess the requisite qualifications and experience appropriate to the tasks they will perform under this Agreement.
- xiii. Any change of the sub-contractor (s), after the arrangement is firmed up, will be made by the Systems Integrator only with the prior written approval of the Authority which approval shall not be unreasonably withheld and only from amongst those sub-contractor(s), as proposed by the Systems Integrator in its bid.
- xiv. The Authority's decision shall notify the Systems Integrator within fourteen (14) working days of receipt of request for such change along with all necessary documents in support of the requested change provided, however, that request for change is received at least one (1) month prior to the schedule start of the relevant activity.
- xv. The Systems Integrator shall be responsible and shall ensure the proper execution and performance of the services or tasks so sub-contracted and shall be liable for any non-performance or breach by such sub-contractor. The Systems Integrator indemnifies and shall keep indemnified the Authority against any losses, damages, claims or such other implications arising from or out of the acts and omissions of such sub-contractor. The Systems Integrator shall be responsible for making all payments to the sub-contractor as may be necessary, in respect of any work performed or task executed, and the Authority shall not be responsible for any part or full payment, which is due to such sub-contractor.
- xvi. All rights of use of any process, service or facility developed or any other task performed by the sub-contractor for the Systems Integrator for the purposes of this Agreement, under a subcontract/agreement would lie exclusively with the Authority in perpetuity free from all liens, encumbrances and other third party rights and the Systems Integrator shall, wherever required take all steps that may be necessary to ensure the use of such rights by the Authority. Ownership and all rights of use of all deliverables / documents/ reports etc. supplied by the Systems Integrator and/or by authorized sub-contractor for the Systems Integrator for the purposes of this Agreement, under a subcontract/agreement would lie exclusively with the Authority in perpetuity free from all liens, encumbrances and other third party rights and the Systems Integrator shall, wherever required take all steps that may be necessary to ensure the ownership and use of such rights by the Authority. Authority shall own and have a right in perpetuity to use all newly created Intellectual Property Rights which have been developed by the sub-contractor solely during execution of this Agreement. The Systems Integrator will provide the undertakings given by the sub-contractor within 30(thirty) days from the date of appointment of sub-contractor to disclose all such Intellectual Property Rights arising in performance of the Services to the

Authority and execute all such agreements/documents and file all relevant applications, effect transfers and obtain all permits and approvals that may be necessary in this regard to effectively transfer and conserve the Intellectual Property Rights of the Authority.

- xvii. Nothing in this Agreement or any delegation/subcontract agreement hereunder shall relieve the Systems Integrator from its liabilities or obligations under this Agreement to provide the Services in accordance with this Agreement.
- xviii. Where the Authority deems necessary, it shall have the right to require replacement of any sub-contractor with another sub-contractor and the Systems Integrator shall in such case terminate forthwith all agreements/contracts other arrangements with such delegate/ sub-contractor and find of the suitable replacement for such delegate/ sub-contractor to the satisfaction of the Authority at no additional charge. Failure on the part of the Systems Integrator to find a suitable replacement and/or terminate all agreements/contracts with such sub-contractor, shall amount to a breach of the terms hereof and the Authority in addition to all other rights, have the right to claim damages and recover from the Systems Integrator all losses/ or other damages that may have resulted from such failure. Further, in case the Systems Integrator terminates any contract/arrangement or agreement with a sub-contractor for any reason whatsoever, the Systems Integrator shall ensure the smooth continuation of Services by providing forthwith, a suitable replacement which is acceptable to the Authority at no additional charge. In case of a replacement of the sub-contractor, the new sub-contractor shall meet the technical and financial qualifications
- xix. In the event of termination of this Agreement, the Authority reserves the right to require the continued performance or execution of all sub-contracts or contracts which the Systems Integrator had originally entered into with any delegate/ sub-contractor, irrespective of whether the Systems Integrator continues to perform its designated role. The above obligation of the delegate/sub-contractor shall be in accordance with the Deed of Adherence and Undertaking provided by the delegate/ sub-contractor to the System Integrator.

### **31.4 Care to be taken while working at Public Place**

Systems Integrator should follow instructions issued by Authority or its nominated Agency from time to time for carrying out work at public places. Systems Integrator should ensure that there is no damage caused to any private or public property. In case such damage is caused, Systems Integrator shall immediately bring it to the notice of concerned organization and the Authority in writing and pay necessary charges towards fixing of the damage. Systems Integrator should also ensure that no traffic ~~congestion~~ public inconvenience is caused while carrying out work at public places.

Systems Integrator shall ensure that its employees/representatives don't breach privacy of any citizen or establishment during the course of execution or maintenance of the project.

### **31.5 Compliance with Laws**

The Systems Integrator shall provide the Services and carry out their obligations under the Agreement with due diligence, efficiency and professionalism/ethics in accordance with generally accepted professional standards and practices. The Systems Integrator shall always act as faithful advisors in respect of any matter relating to this Agreement. The Systems Integrator shall abide by all the provisions/Acts/Rules/Regulations, Standing orders, etc. of Information Technology as prevalent in the country. The Systems Integrator shall also conform to the standards laid down by Authority or Government of India as notified from time to time. The Systems Integrator shall pay fair and reasonable wages to the workmen employed by them, for carrying out the Services and providing the Deliverables under the Agreement undertaken by them and comply with the provisions ~~seforth~~ under the Minimum wages Act and ~~the~~ Contract ~~Labou~~ Act 1970.

### **31.6 Independent SI**

Nothing in this Agreement shall be construed as establishing or implying any partnership or joint venture or ~~employment relationship~~ joint venture between the Parties to this Agreement. Except as expressly stated in this

Agreement nothing in this Agreement shall be deemed to constitute any Party as the agent of any other Party or authorizes either Party

- i. To incur any expenses on behalf of the other Party,
- ii. To enter into any engagement or make any representation or warranty on behalf of the other Party,
- iii. To pledge the credit of or otherwise bind or oblige the other Party,
- iv. To commit the other Party in any manner whatsoever in each case without obtaining the other Party's prior written consent.

**31.7 Waiver**

A waiver of any provision or breach of this Agreement must be in writing and signed by an authorized official of the Party executing the same. No such waiver shall be construed to affect or imply a subsequent waiver of the same provision or subsequent breach of this Agreement.

**31.8 Notices**

Any notice or other document, which may be given by either Party under this Agreement, shall be given in writing in person or by pre-paid recorded delivery post.

In relation to a notice given under this Agreement, any such notice or other document shall be addressed to the other Party's principal or registered office address as set out below

Managing Director,

**Kerala Fibre Optic Network Ltd.**

\_\_\_\_\_  
\_\_\_\_\_

**Systems Integrator**

-----  
-----

Tel: -----

Fax: -----

Any notice or other document shall be deemed to have been given to the other Party when delivered (if delivered in person) if delivered between the hours of 9.30 am and 5.30 pm at the address of the other Party set forth above or on the next working day thereafter if delivered outside such hours, and 7 calendar days from the date of posting (if by letter).

Either Party to this Agreement may change its address and contact details by giving the other reasonable prior written notice of the new information and its effective date.

**31.9 Performance Security / Performance Security**

- i. The Systems Integrator shall submit within 15 days from the receipt of Letter of Intent, performance security in the form of a bank guarantee which is unconditional & irrevocable equal to 10% of the Total CAPEX



value in the format prescribed in the Tender. The performance security shall be valid for the entire Term of the Agreement (including any extension) and 3 months thereafter. If the Performance Security is liquidated /encashed, in whole or in part, during the currency of the Performance Security, the Systems Integrator shall top up the Performance Security with the same amount as has been encashed within 15 days of such encashment without demur.

- ii. The Performance Security shall be forfeited/ invoked by the Authority in the event of failure to complete obligations or breach of any of the obligations, warranties or representations by the System Integrator. Notwithstanding and without prejudice to any rights whatsoever of the Authority under the Agreement in the matter, the proceeds of the Performance Security shall be payable to the Authority as compensation for any loss resulting from the System Integrator's failure to perform/comply its obligations under the Agreement. The Authority shall notify the Systems Integrator in writing of the exercise of its right to receive such compensation within 30(thirty) days, indicating the contractual obligation(s) for which the Systems Integrator is in default.
- iii. The Authority shall also be entitled to make recoveries from the System Integrator's bills, Performance security, or from any other amount due to him, an equivalent value of any payment made to him due to inadvertence, error, collusion, misconstruction or misstatement.
- iv. In case the Project is delayed beyond the Timelines, the Performance security shall be accordingly extended by the Systems Integrator till completion of scope of work as mentioned in the Agreement and the Tender.

### **31.10. Personnel/Employees**

- i. Personnel/employees assigned by Systems Integrator to perform the services shall be employees of Systems Integrator or its sub-contractors, & under no circumstances will such personnel be considered as employees of Authority. Systems Integrator shall have the sole responsibility for supervision & control of its personnel & for payment of such personnel's employee's entire compensation, including salary, legal deductions withholding of income taxes & social security taxes, worker's compensation, employee & disability benefits & the like & shall be responsible for all employer obligations under all laws as applicable from time to time. The Authority shall not be responsible for the above issues concerning to personnel of System Integrator.
- ii. Systems Integrator shall use its best efforts to ensure that sufficient Systems Integrator personnel are employed to perform the Services, & that, such personnel have appropriate qualifications to perform the Services. Authority or its nominated agencies shall have the right to require the removal or replacement of any Systems Integrator personnel performing work under this Agreement. In the event that Authority requests that any Systems Integrator personnel be replaced, the substitution of such personnel shall be accomplished pursuant to a mutually agreed upon schedule & upon clearance of the personnel based on profile review & upon schedule & upon clearance of the personnel based on profile review & personal interview by Authority or its nominated agencies, within not later than 30 working days. Systems Integrator shall depute quality team for the project & as per requirements; Authority shall have the right to ask Systems Integrator to change the team.
- iii. Management (Regional Head / VP level officer) of Systems Integrator needs to be involved in the project monitoring & should attend the review meeting at least once in a month.
- iv. The profiles of resources proposed by Systems Integrator in the technical proposal, which are considered for Technical Bid evaluation, shall be construed as 'Key Personnel' & the Systems Integrator shall not remove such personnel without the prior written consent of Authority. For any changes to the proposed resources, Systems Integrator shall provide equivalent or more experienced resources in consultation with Authority.
- v. Except as stated in this clause, nothing in this Agreement will limit the ability of Systems Integrator freely to assign or reassign its employees; provided that Systems Integrator shall be responsible, at its expense, for transferring all appropriate knowledge from personnel being replaced to their replacements. Authority shall

have the right to review & approve System Integrator's plan for any such knowledge transfer. Systems Integrator shall maintain the same standards for skills & professionalism among replacement personnel as in personnel being replaced.

- vi. Each Party shall be responsible for the performance of all its obligations under this Agreement & shall be liable for the acts & omissions of its employees & agents in connection therewith.

**31.11. Variations & Further Assurance**

- i. No amendment, variation or other change to this Agreement or the SLAs shall be valid unless made in writing & signed by the duly authorized representatives of the Parties to this Agreement.
- ii. Each Party to this Agreement or the SLAs agree to enter into or execute, without limitation, whatever other agreement, document, consent & waiver & to do all other things which shall or may be reasonably required to complete & deliver the obligations set out in the Agreement or the SLAs.

**31.12. Severability & Waiver**

- i. If any provision of this Agreement or the SLAs, or any part thereof, shall be found by any court or administrative body of competent jurisdiction to be illegal, invalid or unenforceable the illegality, invalidity or unenforceability of such provision or part provision shall not affect the other provisions of this Agreement or the SLAs or the remainder of the provisions in question which shall remain in full force & effect. The relevant Parties shall negotiate in good faith in order to agree to substitute for any illegal, invalid or unenforceable provision a valid & enforceable provision which achieves to the greatest extent possible the economic, legal & commercial objectives of the illegal, invalid or unenforceable provision or part provision within 7(seven) working days.
- ii. No failure to exercise or enforce & no delay in exercising or enforcing on the part of either Party to this Agreement or the SLAs of any right, remedy or provision of this Agreement or the SLAs shall operate as a waiver of such right, remedy or provision in any future application nor shall any single or partial exercise or enforcement of any right, remedy or provision preclude any other or further exercise or enforcement of any other right, remedy or provision.

**31.13. Entire Agreement**

This Agreement, the SLAs & all schedules appended thereto & the contents & specifications of the Volumes I & II of the Tender, subsequent corrigenda issued thereon & clarification (undertakings) accepted by the Authority constitute the entire agreement between the Parties with respect to their subject matter.

**31.14. Survivability**

The termination or expiry of this Agreement or the SLAs for any reason shall not affect or prejudice any terms of this Agreement, or the rights of the Parties under them which are either expressly or by implication intended to come into effect or continue in effect after such expiry or termination.

**31.15. The stamp duty payable for the contract shall be borne by the Systems Integrator**

- 1. Applicable Law

The Agreement shall be governed by the laws and procedures prescribed by the laws prevailing and in force in India (the "Applicable Law"), within the framework of applicable legislation and enactment made from time to time concerning such commercial dealings/processing. Subject to Arbitration clause of this Agreement, all legal disputes are subject to the jurisdiction of Thiruvananthapuram courts only. The parties expressly agree to exclude the application of the U.N. Convention on Contracts for the International Sale of Goods (1980) to this Agreement and the performance of the parties contemplated under this Agreement, to the extent that such convention might otherwise be applicable.

**Volume- I**

---

**IN WITNESS** whereof the parties hereto have signed this on the day, month and year first herein above written.

Signed, sealed and delivered

**By** -----

-----,

For and on behalf of the “Kerala Fibre Optic Network Ltd”

Signed, sealed and delivered

**By** -----

For and on behalf of the “Systems Integrator”,

-----

Witnesses:

(1)

(2)

**Attachments to the Agreement:**

- i) Scope of Services for the Systems Integrator (Annexure I)
- ii) Tender Document issued by the Authority together with the Clarification & Corrigendum Document published by Authority subsequent to the Tender for this work (Annexure II)
- iii) LoI issued by the Authority to the Systems Integrator (Annexure III)
- iv) System Integrator’s “Technical Bid” and “Commercial Bid” submitted in response to the Tender (Annexure IV)
- v) Format of Change Control Notice (Annexure V)
- vi) Schedule for AUDIT, ACCESS AND REPORTING (Schedule 1)
- vii) Exit Management Schedule

**Annexure V: FORMAT FOR CHANGE CONTROL NOTICE**

<b>CCN Number:</b> Number>>
<b>Change of Control Details:</b>

## Volume- I

<b>Before Change of Control</b>	<b>After Change of Control (Surviving Entity)</b>
Legal Name of Entity:	Legal Name of Entity:
Registered Office Address:	Registered Office Address:
Date of Incorporation (as per Companies Act, 1956):	Date of Incorporation of Surviving Entity (as per Companies Act, 1956):
Annual Turnover (in INR) during last three Financial Years	Annual Turnover (in INR) during last three Financial Years
Entity Financial Net worth (measured as paid-up capital plus free reserves) (total assets minus total liabilities)	Entity Financial Net worth (measured as paid-up capital plus free reserves) (total assets minus total liabilities)
<b>Name &amp; Designation:</b>	
Signature	
Name:	
Designation:	
Date:	

**Note:** All the information provided above should be supported by documentary evidences signed by concerned authorized signatories and the client may ask for any additional information as desired in case of occurrence of a Change of Control event.

## **SCHEDULE- I - AUDIT, ACCESS AND REPORTING**

### **1. PURPOSE**

This Schedule details the audit, access and reporting rights and obligations of Authority and/or its nominated agency and the SYSTEMS INTEGRATOR and its sub-contractors, agents, supplier etc. This Schedule is in addition to, and in derogation of, the audit rights and process provided in the Tender.

### **2. AUDIT NOTICE AND TIMING**

2.1 As soon as reasonably practicable after the Effective Date, the Parties shall use their best endeavours to agree to a timetable for routine audits (Other than those mentioned as part of the mandatory requirements for successful delivery and acceptance of the System) during the Project Implementation Phase and the Operation and

Maintenance Phase. Such timetable during the Implementation Phase, and thereafter during the operation Phase, Authority shall conduct routine audits in accordance with such agreed timetable and shall not be required to give the Systems Integrator any further notice of carrying out such audits.

2.2 Authority may conduct non-timetabled audits at his/ her own discretion if it reasonably believes that such non-timetabled audits are necessary as a result of an act of fraud by the System Integrator, a security violation, or breach of confidentiality obligations by the System Integrator, provided that the requirement for such an audit is notified in writing to the Systems Integrator a reasonable period time prior to the audit (taking into account the circumstances giving rise to the reasonable belief) stating in a reasonable level of detail the reasons for the requirement and the alleged facts on which the requirement is based. If the Systems Integrator considers that the non-timetabled audit was not appropriate, the matter shall be referred to the escalation procedure as set out in the Project Governance and Management section of RfP.

2.3 Except as provided in 2.2 above, audits shall be conducted by with adequate notice of 2 weeks to the System Integrator.

### **3. ACCESS**

The Systems Integrator shall provide to Authority and/or its nominated agency reasonable access to employees, sub-contractors, suppliers, agents and third party facilities as detailed in the RfP, documents, records and systems reasonably required for audit and shall provide all such persons with routine assistance in connection with the audits and inspections. Authority or its nominated agency shall have the right to copy and retain copies of any relevant records. The Systems Integrator shall make every reasonable effort to co-operate with them.

### **4. AUDIT RIGHTS**

Authority and/or its nominated agency shall have the right to audit and inspect suppliers, agents, sub-contractors and third party facilities (as detailed in the RfP), data centre, documents, records, procedures and systems relating to the provision of the services, but only to the extent that they relate to the provision of the services, as shall be reasonably necessary to verify:

- a) The security, integrity and availability of all data processed, held or conveyed by the Partner on behalf of Authority and documentation related thereto;
- b) That the actual level of performance of the services is the same as specified in the SLA;
- c) That the Systems Integrator has complied with the relevant technical standards, and has adequate internal controls in place; and
- d) The compliance of the Systems Integrator with any other obligation under the Agreement.
- e) Unless otherwise provided in the RfP, Security audit and implementation audit of the system shall be done once each year, the cost of which shall be borne by Authority.

For the avoidance of doubt the audit rights under this Schedule shall not include access to the Systems Integrator's profit margins or overheads, any confidential information relating to the System Integrator' employees, or (iii) minutes of its internal Board or Board committee meetings including internal audit, or (iv) such other information of commercial-in-confidence nature which are not relevant to the Services associated with any obligation under the AGREEMENT.

### **5. AUDIT RIGHTS OF SUB-CONTRACTORS, SUPPLIERS AND AGENTS**

5.1 The Systems Integrator shall use reasonable endeavours to achieve the same audit and access provisions as defined in this Schedule with sub-contractors, suppliers and agents who supply labour, services, equipment or

materials related to performance of obligations by Systems Integrator under this Agreement. The Systems Integrator shall inform Authority and/or its nominated agency prior to concluding supply/subcontract agreements of any failure to achieve the same rights of audit or access.

- 5.2 REPORTING: The Systems Integrator will provide quarterly reports to Authority and/or its nominated agency regarding any specific aspects of the Project and in context of the audit and access information as required by Authority or its nominated agency.

## **6. ACTION AND REVIEW**

- 6.1 Any change or amendment to the systems and procedures of the System Integrator, where applicable arising from the audit report shall be agreed within thirty (30) calendar days from the submission of the said report.
- 6.2 Any discrepancies identified by any audit pursuant to this Schedule shall be immediately notified to Authority or its nominated agency and the Systems Integrator Project Manager who shall determine what action should be taken in respect of such discrepancies in accordance with the terms of this Agreement.

## **7. TERMS OF PAYMENT**

Except as otherwise provided in RfP, Authority shall bear the cost of any audits and inspections. The Systems Integrator shall bear all costs for all reasonable assistance and information provided under this Agreement, the Project Implementation, Operation and Maintenance SLA by the Systems Integrator OR pursuant to this Schedule.

## **8. RECORDS AND INFORMATION**

For the purposes of audit in accordance with this Schedule, the Systems Integrator shall maintain true and accurate records in connection with the provision of the services and the Systems Integrator shall handover all the relevant records and documents upon the termination or expiry of this Agreement.



Tender Ref No: KSITIL/MD/KFON/18/1852

**Volume - II**  
**Scope of Work & Technical Specifications**  
**June 2018**

**Published by**  
**Kerala State Information Technology Infrastructure Ltd.**

*TC No.: 14/196/2, 3rd Floor,  
Chandrasekharan Nair Stadium,  
Palayam, Trivandrum - 695033*

## **DISCLAIMER**

The information contained in this Tender or subsequently provided to Applicants, whether verbally or in documentary or any other form by or on behalf of the Authority or any of its employees or advisers, is provided to Applicants on the terms and conditions set out in this Tender and such other terms and conditions subject to which such information is provided.

This Tender is issued by the Managing Director, Kerala State IT Infrastructure Ltd on behalf of Kerala Fibre Optic Network Ltd. This Tender is not an agreement and is neither an offer nor invitation by the Authority to the prospective Applicants or any other person. The purpose of this Tender is to provide interested parties with information that may be useful to them in the formulation of their Bid pursuant to this Tender. This Tender includes statements, which reflect various assumptions and assessments arrived at by the Authority in relation to solution for Kerala Fibre Optic Network and Reliable Communication and Data Acquisition Network. Such assumptions, assessments and statements do not purport to contain all the information that each Applicant may require. This Tender may not be appropriate for all persons, and it is not possible for the Authority, its employees or advisers to consider the objectives, technical expertise and particular needs of each party who reads or uses this Tender. The assumptions, assessments, statements and information contained in this Tender, may not be complete, accurate, adequate or correct. Each Applicant should, therefore, conduct its own investigations and analysis and should check the accuracy, adequacy, correctness, reliability and completeness of the assumptions, assessments and information contained in this Tender and obtain independent advice from appropriate sources.

Information provided in this Tender to the Applicants is on a wide range of matters, some of which depends upon interpretation of law. The information given is not an exhaustive account of statutory requirements and should not be regarded as a complete or authoritative statement of law. The Authority accepts no responsibility for the accuracy or otherwise for any interpretation or opinion on the law expressed herein.

The Authority, its employees and advisers make no representation or warranty and shall have no liability to any person including any Applicant under any law, statute, and rules or regulations or tort, principles of restitution or unjust enrichment or otherwise for any loss, damages, cost or expense which may arise from or be incurred or suffered on account of anything contained in this Tender or otherwise, including the accuracy, adequacy, correctness, reliability or completeness of the Tender and any assessment, assumption, statement or information contained therein or deemed to form part of this Tender or arising in any way in this selection process.

The Authority also accepts no liability of any nature whether resulting from negligence or otherwise however caused arising from reliance of any Applicant upon the statements contained in this Tender. The Authority may in its absolute discretion, but without being under any obligation to do so, update, amend or supplement the information, assessment or assumption contained in this Tender. The issue of this Tender does not imply that the Authority is bound to select an Applicant or Applicants, as the case may be, for the implementation of Kerala Fibre Optic Network and Reliable Communication and Data Acquisition Network and the Authority reserves the right to reject all or any of the Proposals without assigning any reason whatsoever.

The Applicant shall bear all its costs associated with or relating to the preparation and submission of its Proposal including but not limited to preparation, copying, postage, delivery fees, expenses associated with any demonstrations or presentations which may be required by the Authority or any other costs incurred in connection with or relating to its Proposal. All such costs and expenses will remain with the Applicant and the Authority shall not be liable in any manner whatsoever for the same or for any other costs or other expenses incurred by an Applicant in preparation or submission of the Bid, regardless of the conduct or outcome of the selection process.



# Table of Contents

<b>DISCLAIMER.....</b>	
<b>TABLE OF CONTENTS.....</b>	
<b>SECTION I .....</b>	
<b>1. PROJECT BACKGROUND .....</b>	
<b>2. PROPOSED NETWORK .....</b>	
2.1. CORE NETWORK .....	11
2.1.1. Point of Presence (PoPs) .....	
2.1.2. Core Ring .....	
2.1.3. Aggregation Ring .....	
2.1.4. Pre-Aggregation Ring.....	
2.1.5. NOC .....	
2.2. ACCESS NETWORK.....	13
<b>3. SCOPE OF WORK .....</b>	
3.1. BROAD SCOPE OF WORK .....	14
3.2. DESIGN OPTIMIZATION .....	15
3.3. SETTING UP OF POps.....	16
3.4. FIBRE LAYING .....	16
3.5. COMMISSIONING OF ELECTRONIC EQUIPMENT .....	18
3.6. NETWORK OPERATING CENTRE (NOC).....	18
3.7. LAST MILE CONNECTIVITY .....	20
3.8. PREPARATION AND IMPLEMENTATION OF INFORMATION SECURITY POLICY .....	20
3.9. SUGGESTIONS ON NETWORK UPGRADE.....	21
<b>4. NETWORK DESIGN CONSIDERATIONS FOR KFON .....</b>	
4.1. GENERAL GUIDELINES.....	21
4.2. CORE RING .....	21
4.3. AGGREGATION RING.....	21
4.4. PRE- AGGREGATION RING.....	22
4.5. LAST MILE CONNECTIVITY .....	22
<b>5. FUNCTIONAL REQUIREMENTS .....</b>	
5.1. FUNCTIONAL REQUIREMENTS FOR CORE NETWORK .....	22
5.2. FUNCTIONAL REQUIREMENTS FOR NOC .....	26
5.3. FUNCTIONAL REQUIREMENTS FOR GPON.....	28
<b>6. COMMON GUIDELINES REGARDING COMPLIANCE OF EQUIPMENT/SYSTEM .....</b>	
<b>7. BILL OF MATERIAL.....</b>	
7.1. BILL OF MATERIAL FOR PACKAGE A .....	31
<b>SECTION II.....</b>	
<b>1. INTRODUCTION .....</b>	
1.1. PROJECT OVERVIEW .....	39
1.2. EXISTING COMMUNICATION SYSTEM .....	39
1.3. SCOPE OF WORK .....	39
1.4. SCHEDULE OF REQUIREMENT & DELIVERY.....	41
1.4.1. Test Equipment.....	
<b>SECTION III .....</b>	

<b>1. SURVEY AND PLANNING</b> .....	
1.1. AS-BUILT DIAGRAMS .....	43
<b>SECTION IV</b> .....	
<b>1. NETWORK COMPONENT SPECIFICATION</b> .....	
1.1. ACTIVE COMPONENTS .....	47
1.1.1. NOC Router.....	
1.1.2. Core Router .....	
1.1.3. Aggregation Router .....	
1.1.4. Pre-Aggregation Router .....	
1.1.5. Spur Router .....	
1.1.6. Internet Router .....	
1.1.7. DWDM.....	
1.1.8. Server.....	
1.1.9. Blade Chassis .....	
1.1.10. Primary Storage.....	
1.1.11. Secondary Storage .....	
1.1.12. Enterprise Management System (EMS).....	
1.1.13. GPON EMS .....	
1.1.14. Core switch.....	
1.1.15. Aggregation Switch.....	
1.1.16. Access Switch .....	
1.1.17. GPON OLT.....	
1.1.18. GPON ONT .....	
1.1.19. Workstation .....	
1.1.20. Desktop .....	
1.1.21. Network Colour Laser Printer .....	
1.1.22. IP Phone & IP PBX .....	
1.1.23. Helpdesk .....	
1.1.24. Video Wall / Video Screen.....	
1.1.25. Video Management Solution .....	
1.1.26. LCD Projector.....	
1.1.27. KVM Module (If required) .....	
1.1.28. Online UPS.....	
1.1.29. DG Set.....	
1.1.30. DC Firewall .....	
1.1.31. URL Filtering Firewall.....	
1.1.32. Indoor Fixed Dome Camera with PoE at NOC & PoP locations .....	
1.1.33. Antivirus software .....	
1.1.34. Database Licenses .....	
1.1.35. Backup Software .....	
1.1.36. GIS Software License.....	
1.1.37. Public Addressable System.....	
1.1.38. Project Management Software.....	
1.1.39. Fibre Monitoring System.....	
1.1.40. Integrated Building Management Solution .....	
1.1.41. Rodent Repellent .....	
1.1.42. Water Leak Detection System .....	
1.1.43. Fire Suppression System .....	
1.1.44. Fire Alarm System .....	
1.1.45. Aspirating Smoke Detection System .....	
1.1.46. Access Control System.....	
1.1.47. Customized Billing Solution- BSS.....	
1.2. PASSIVE COMPONENTS .....	143
1.2.1. General Requirements for Optical fibre.....	

1.2.2.	Technical Specifications for Single Mode Optical Fibre .....	
1.2.3.	Aerial ADSS OF Cable (48/24/12F) & Associated Hardware & Fittings .....	
1.2.4.	Underground OFC - 48 F - Armoured Non-Metallic .....	
1.2.5.	Accessories for Aerial ADSS Fibre Cable - Wedge Type .....	
1.2.6.	Aerial Drop Cable - 4F .....	
1.2.7.	Aerial Drop Cable Accessories.....	
1.2.8.	High Density Fibre Distribution Frame (FDMS Type I) .....	
1.2.9.	Optical Splitter .....	
1.2.10.	Spare Cable Box Type A (at PoP locations) .....	
1.2.11.	Runway segments for PoPs .....	
1.2.12.	Street Box Type I (Joint Closure (Dome Type)).....	
1.2.13.	FTB Type I.....	
1.2.14.	Street box Type II (FTB Type II).....	
1.2.15.	Fibre Patch Cord .....	
1.2.16.	Rack Cabinets .....	
1.2.17.	Pre-fabricated Shelter .....	
1.2.18.	Pole .....	
1.2.19.	OPGW Cable.....	
1.2.19.6.	Optical Fibre Splices.....	
1.2.19.7.	Fibre Optic Distribution Panel.....	
1.2.19.8.	Optical Fibre Termination and Splicing .....	
1.2.19.9.	Optical Fibre Connectors .....	
1.2.19.10.	Service Loops .....	
1.2.19.11.	Methodology for Installation and Termination .....	
1.2.19.12.	Fibre Optic Approach cables and its accessories .....	
1.2.19.13.	PLB HDPE Pipe & Accessories .....	
1.3.	DATA REQUIREMENT SHEET .....	230
1.3.1.	Data Requirements Sheets for Optical Fibre used in OPGW/ ADSS/ UG/Approach Cable .....	
1.3.2.	Data Requirement Sheet for 48F ADSS with 100 Kmph wind speed .....	
1.3.3.	Data Requirement Sheet for 48F ADSS with 150 Kmph wind speed .....	
1.3.4.	Data Requirement Sheet for 24F ADSS with 100 Kmph wind speed .....	
1.3.5.	Data Requirement Sheet for 12F ADSS with 100 Kmph wind speed .....	
1.3.6.	Data Requirement Sheet for Aerial Drop Cable.....	
1.3.7.	Data Requirements Sheets for ADSS Cable Accessories .....	
1.3.8.	Data Requirement Sheet for Drop Cable Accessories .....	
1.3.9.	Data Requirement Sheet for Overhead Fibre Optic Cable - OPGW .....	
1.3.10.	Data Requirement Sheet for OPGW Accessories .....	
1.3.11.	Data Requirements Sheet for Approach Cable/UG Cable.....	
1.3.12.	Data Requirements Sheet for PLB Pipe .....	
1.4.	OPERATIONAL FACILITIES REQUIREMENTS SPECIFICATIONS .....	266
1.4.1.	NOC Layout & Cabling.....	
1.4.2.	Humidity, Ventilation and Air Conditioning systems .....	
1.4.3.	Civil & Architectural work.....	
1.4.4.	PVC Conduit .....	
1.4.5.	Wiring .....	
1.4.6.	Cable Work.....	
1.4.7.	Electrical Panels .....	
1.4.8.	Circuit Compartments .....	
1.4.9.	Instrument Compartments .....	
1.4.10.	Busbars .....	
1.4.11.	Electrical Power and Control Wiring Connection .....	
1.4.12.	Terminals.....	
1.4.13.	Cable Compartments .....	
1.4.14.	Labels.....	
1.4.15.	Name Plates .....	
1.4.16.	Danger Notice Plates.....	

1.4.17. Molded Case Circuit Breakers.....  
1.4.18. Contactors .....  
1.4.19. Indicating Lamps .....  
1.4.20. Cable Trays .....  
1.4.21. Earthing .....

**SECTION V .....**

**1. PROJECT MANAGEMENT, SCHEDULE AND IMPLEMENTATION PLAN .....**

1.1. PROJECT GOVERNANCE STRUCTURE ..... 275  
1.2. STAKEHOLDERS OF THE PROJECT & THEIR RESPONSIBILITIES ..... 275  
    1.2.1. Systems Integrator .....  
    1.2.2. Project Monitoring Agency (PMA).....  
    1.2.3. Project Management Unit (PMU) .....  
    1.2.4. KSEBL .....  
    1.2.5. Authority .....  
1.3. PROJECT OFFICE & TEAM..... 277  
1.4. REPORTING & MEETINGS ..... 278  
    1.4.1. Progress Reporting .....  
        1.4.1.1. Monthly Progress Reports .....  
        1.4.1.2. Bi-Monthly Progress Review Meetings .....  
    1.4.2. Transmittals.....  
    1.4.3. Quality Assurance.....  
    1.4.4. Document Review and Approval Rights .....  
1.5. PROJECT SCHEDULE..... 281  
    1.5.1. Implementation Schedule .....  
    1.5.2. Training Schedule .....

**2. HAND-OVER/TAKE OVER (HOTO) .....**

**3. OPERATIONS & MAINTENANCE .....**

**4. TRAINING & SUPPORT SERVICES .....**

4.1. TRAINING ..... 286  
4.2. OVERVIEW TRAINING ..... 286  
4.3. SUPERVISION, MAINTENANCE AND INSTALLATION CREW TRAINING AT SITE ..... 286  
4.4. TRAINING COURSE REQUIREMENTS AND SCHEDULE (AUTHORITY’S PROPOSAL)..... 287  
4.5. MANUALS AND EQUIPMENT ..... 287  
4.6. SUPPORT SERVICES ..... 287  
    4.6.1. Technical Support .....

**5. INSPECTION & TESTING .....**

5.1. GENERAL REQUIREMENTS ..... 288  
5.2. INSPECTION ..... 288  
5.3. TEST PLANS AND PROCEDURES..... 289  
    5.3.1. Test Plans .....  
    5.3.2. Test Procedures .....  
    5.3.3. Test Records .....  
    5.3.4. Rejection of Elements .....  
5.4. ACCEPTANCE TESTING ..... 291

**6. DOCUMENTATION AND DELIVERABLES .....**

6.1. SYSTEM DOCUMENTATION..... 293  
6.2. SUPPLEMENTARY DOCUMENTATION ..... 293  
6.3. TEST DOCUMENTATION ..... 293  
6.4. DRAWINGS ..... 293  
6.5. DRAWING AND DOCUMENT APPROVAL PROCEDURE..... 294

**Volume- II**

---

6.6. FINAL DOCUMENTATION ..... 294

**7. HEALTH, SAFETY AND ENVIRONMENTAL PLAN.....**

7.1. CONTRACT CONDITIONS..... 299

7.2. GENERAL REQUIREMENTS ..... 299

7.3. REPORTING OF INCIDENTS, AND HOURS WORKED..... 300

7.4. NON-COMPLIANCE ..... 300

7.5. SITE HEALTH AND SAFETY CONTROLS..... 300

    7.5.1. *Project Planning* .....

**ANNEXURE I - INSTALLATION GUIDELINES FOR ADSS CABLE.....**

**ANNEXURE II - ENGINEERING GUIDELINES FOR UG CABLE LAYING .....**

**ANNEXURE III - GENERAL GUIDELINES REGARDING EXECUTION OF WORK .....**

**ANNEXURE IV - ACCEPTANCE TEST PROCEDURE .....**

**ANNEXURE V - FIBRE CABLE TESTS .....**

**ANNEXURE VI - ACCEPTANCE TEST FORMATS .....**

**ANNEXURE VII - GIS DATA FORMAT .....**

**SECTION I**  
***Package A - Design, Implementation and Maintenance of  
Optic Network***

## 1. Project Background

Kerala has achieved the distinction of a state having highest tele-density in the country, with the figure at 119.08, as per the TRAI (Telecom Regulatory Authority of India) indicator reports Kerala has 189.3 Lakh internet subscribers of which 71.1 Lakh subscribers are from rural areas and 118.2 Lakh are urban subscribers. In addition, the State has an internet penetration of 52.42 people per 100 population, which is significantly higher than the national metric of 34.42 people per 100 population.

Government of Kerala now wishes to build a dedicated optical fibre network capable of efficient service delivery, assured Quality of Service (QoS), reliability, interoperability, redundancy, security and scalability.

### Key Outcomes

- ξ Create a highly scalable and resilient core optical fibre network across the State and also to provide non-discriminatory access to service and content providers
- ξ Be an Infrastructure Service Provider and provide free/subsidized internet to targeted sections of households through service providers
- ξ Setup an access network to connect to 30,000+ govt. & educational institutions and provide infrastructure for extending the connectivity to 20 lakhs economically backward households utilizing the existing service provider network wherever available

### Project Structure

- ξ **Track 1:** Build a highly scalable and resilient core network and create an access to connect 30,000+ government and educational institutions.
- ξ **Track 2:** Collaborate with regional service providers to provide free internet to 20 lakhs economically backward households.

### Envisaged Benefits

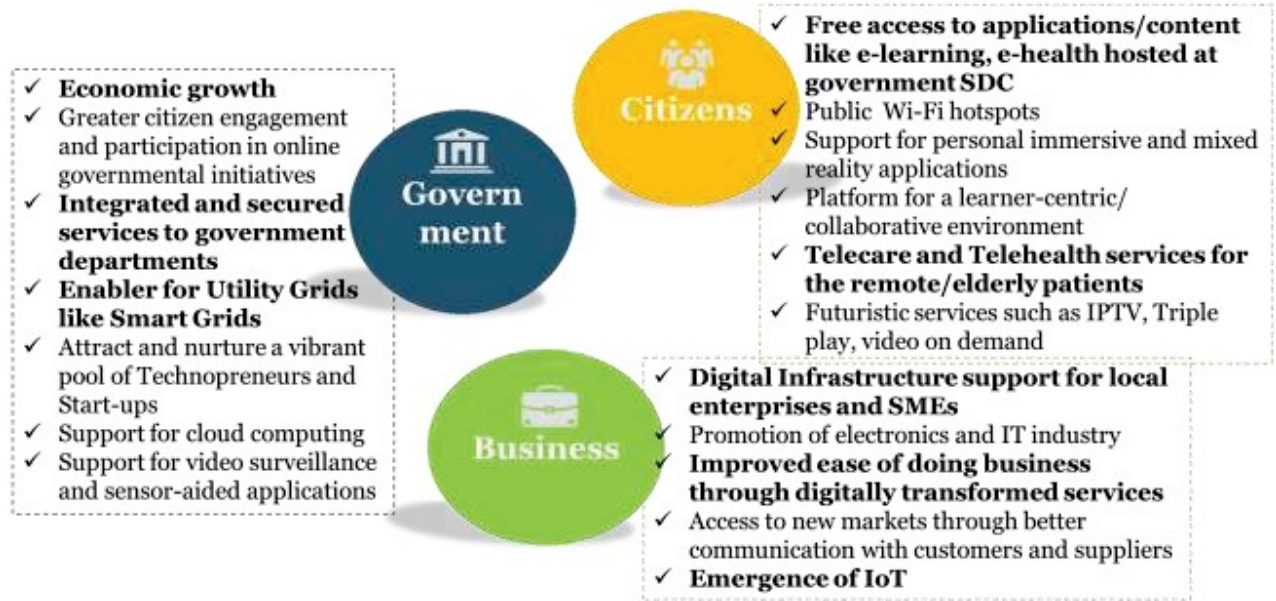
The expansion of the digital economy has been rapid and the thirst for higher broadband capacities is ever increasing in the country. The vision of Digital India has further enhanced the need for reliable and fast connectivity to reach nook and corner of the country. Today applications have moved from a data based to more bandwidth intensive applications like e-Governance, e-Health, CCTNS, e-Visas, etc. to name a few. Digital forces of social media, mobility, analytics, and cloud are shaping the new virtual world today. Undoubtedly, broadband is the lifeline of the digital world.

Kerala Fibre Optic Network will support the inclusion of almost all digital assets onto a common platform, which will ensure confluence of data from multiple sources, applications, objects and people. The establishment of this project will provide high quality, reliable, cost effective and sustainable network to Government of Kerala. The provisioning of the core network will ensure connectivity to the data centres and control rooms with scalable capacities to allow for expansion in the future. This project will have multi fold benefits across the government departments and citizens will feel the effect.

Like any other major infrastructure project, KFON will produce a range of indirect benefits to the State. Though quantifying these benefits are sometimes speculative and may not always be accurate, several studies have attempted to assess the expected indirect benefits of such high-speed broadband projects. Some of the major economic benefits of KFON are its impact on GSDP and creation of jobs.

---

<sup>1</sup> Yearly Performance Indicators of Indian Telecom Sector (Second Edition), Dec. 2017 by TRAI





## 2. Proposed Network

The entire network is divided into two – Core Network and Access Network. The high-level network architecture is as shown in the diagram below.

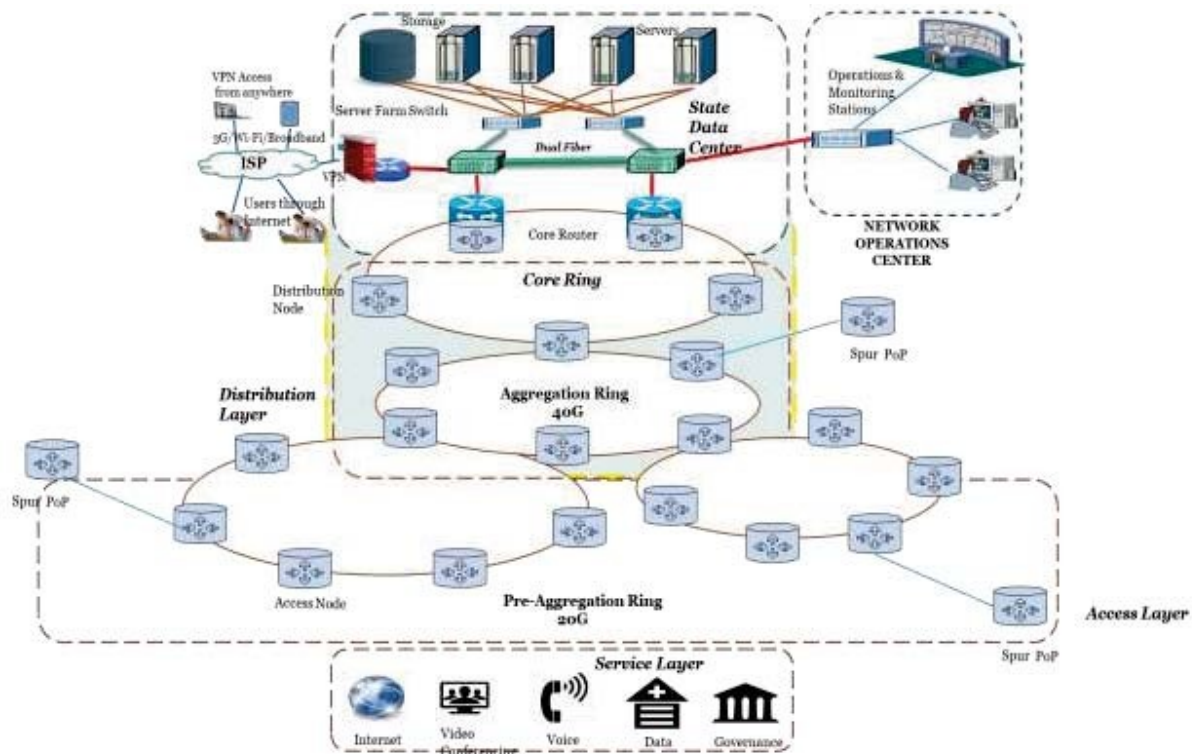


Figure 1: Network Architecture

### 2.1. Core Network

Kerala Fibre Optic Network will be using Internet Protocol - Multiprotocol Label Switching (IP/MPLS) to construct a packet-switched transport network. This will provide a common set of functions to support the operational models and capabilities required for such critical networks. IP/MPLS will provide connection-oriented paths, protection and restoration mechanisms, comprehensive Operations, administration, and Maintenance (OAM) functions for seamless network operation using dynamic control plane.

The network will have distributed architecture and will have three layers:

- ξ Core layer
- ξ Aggregation layer
- ξ Pre Aggregation layer

As this network is hierarchical, and the networks of different layers have different reliability requirements. The Core, Aggregation and Pre-aggregation should be high availability network, whereas the access network shall have proper tradeoff between cost and high availability.

The users shall expect high QoS of the services consumed, and require higher reliability, network reliability should cater to large mean time between failures (MTBF). And the network reliability solution must cover all the three aspects: Equipment, Topology and Services

Network will be on own fibre network. The proposed network will support MPLS based Ring topology (Single Homed /Dual Homed) to provide following:

- ξ Redundancy of nodes and links
- ξ Better link utilization
- ξ Dedicated and predefined path for critical application
- ξ Easy insertion of new node.
- ξ QoS for video and critical data
- ξ Segregation of critical and non-critical traffic

### **2.1.1 Point of Presence (PoPs)**

The proposed PoPs for Kerala Fibre Optic Network shall be all the KSEBL owned substations of all voltage levels i.e., 33kV, 66kV 110kV, 220kV and 400kV. The complete district wise list of PoPs are provided in the attachments to this Tender Document for reference. These substations shall be divided into Core, Aggregation, Pre-Aggregation and Spur PoPs. The substations which could not be brought under either core, aggregation or pre-aggregation rings shall be treated as Spur PoPs.

### **2.1.2 Core Ring**

One substation in each district which is preferably closer to be District Headquarters shall be the Core PoP. All the Core PoPs shall be interconnected with NOC and State Data Centre, thus creating an inter-district route. This ring will carry all the traffic from the districts up to the NOC and State Data Centre. Also the core ring shall be designed to carry the traffic from each district to each district. The core ring shall be designed to carry 40 Gbps traffic at each district.

### **2.1.3 Aggregation Ring**

Each district will have one aggregation ring which shall connect Core PoP and PoPs near to Core PoP in that district. This layer of the network will aggregate traffic coming from all the horizontal offices connected to the aggregation PoPs, spurs to aggregation rings and pre-aggregation rings' traffic and route it to NOC, Data Centre and district to district through core ring. The traffic will aggregate at Core PoP of the respective district. Each Aggregation Ring shall be of capacity 40 Gbps.

### **2.1.4 Pre-Aggregation Ring**

The remaining rings are considered as pre-aggregation rings to connect it to the aggregation ring. These rings will aggregate at an aggregation PoP and will carry the traffic coming from all the horizontal offices connected to the pre-aggregation PoPs and spurs to pre-aggregation rings. There may be multiple pre-aggregation rings in a district. These rings shall be of capacity 20 Gbps

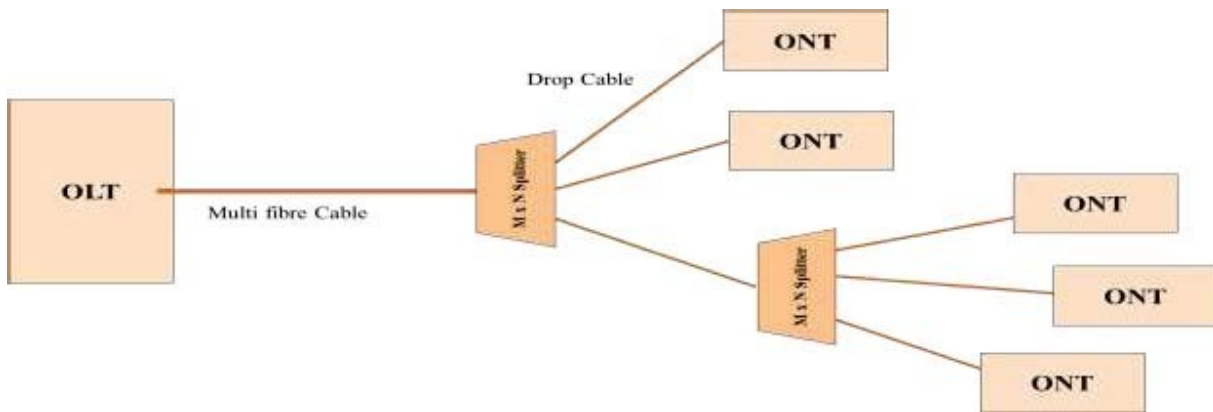
### **2.1.5 NOC**

Kerala Fibre Optic Network scope also covers creation a Network Operation Centre (NOC). The State NOC proposed for Kerala Fibre Optic Network is going to be heart of operations and management of the state wide network being established under the project. KFON will be laying down the infrastructure for providing connectivity to all government and educational institutions and making provisions for leasing dark fibre and selling bulk bandwidth to various service providers to enable delivery of end-user services.

As such managing and servicing the subscribers of these end-user services is not under the scope Kerala Fibre Optic Network. The requirement, therefore, is for a basic billing and accounting software and Customer Relationship Management software. This can either be a COTS solution or a bespoke developed solution as per the requirements of Kerala Fibre Optic Network.

Given the context of Kerala Fibre Optic Network, it entails setting up a passive optical fibre network with IP MPLS network on top of it and enable the delivery of multitude of IT services through this network. To monitor and manage this state wide network, the monitoring and management solutions that need to be deployed at State NOC must cater to the key requirements of Service assurance and Service fulfilment.

## 2.2. Access Network



The horizontal connectivity through the access network, originating from the PoPs of core network is designed to connect the Government and Educational institutions through fibre. The proposed technology for the access network is Passive Optical Network (PON), based on GPON technology (Gigabit Passive Optical Network), considering the cost and complexity involved in providing connectivity to 30,000+ government offices.

## 3. Scope of Work

Scope of work of the Systems Integrator (SI) covers the survey, design, procurement, supply, installation, construction, configuration, testing, commissioning, operation and maintenance of state wide Optical Fibre Cable Network in the state of Kerala. It shall supply commission operate and maintain the associated active (components including NOC components), passive, civil, mechanical and power components. The SI should ensure the successful implementation of the proposed system and provide capacity building support to Authority as per the scope of services described below. Any functionality not expressly stated in this document but required to meet the needs of the Authority to ensure successful operations of the system shall essentially be under the scope of the SI and for that no extra charges shall be admissible.

### 3.1. Broad Scope of Work

- A. Route Survey, Planning and Design
  - i. Capturing the GIS coordinates of the OFC route and all sites being setup and uploading the same to central servers at NOC.
- B. Procurement, Supply and Installation of all material/equipment required for the implementation of following components of the network in 24 months from the date of signing of contract
  - i. Establishment of the Core Rings, Aggregation Rings, Pre-Aggregation Rings and Spur Connectivity as per the final design
  - ii. Setup of Core, Aggregation, Pre-Aggregation and Spur PoPs with all the required networking components
  - iii. Establishment of NOC
    - a) Site preparation and physical infrastructure provisioning like setup of pre-fabricated structures, power, air conditioning etc.
    - b) Supply and installation of Servers, Storage, Networking, Security components
    - c) Supply, installation and customization of the required application software
  - iv. Establishment of GPON last mile network connecting about 30,000+ government and educational institutions
  - v. Ensuring integration of all the network elements with NOC
  - vi. Provision of intranet and internet services to all government and educational offices connected through KFON
- C. Site level coordination with
  - i. KSEBL substation authorities for carrying out laying work and establishment of PoPs in each substation
  - ii. Government institutions for accessing their premises
- D. Providing required support to Authority or its selected agency for conducting verification and acceptance testing processes
- E. The works are to be completed on turnkey basis and the supplied equipment and network are required to be maintained for 7 years from the date of Go-Live. The proposed solution is intended to meet the objectives and SLAs of the Project. SI will be responsible to meet the service levels as mentioned in the tender document. SI is also allowed to improvise the architecture and other components of the solution so that the project meets its objectives.

The detailed scope of work is outlined below.

### 3.2. Design Optimization

As part of implementation of core network, the bidder will be responsible for network design and its optimization, implementation of the network and ensure quality. The design improvisation by bidder should be aimed to ensure service availability and assured quality of service for end users.

1. The design should be improvised to support following essential attributes of a wide area network:
  - Scalability
  - Reliability/ Manageability/Interoperability
  - Security
  - Resiliency
2. KFON will be used to provide services to Government and educational institutions and will also be used by various TSPs/ISPs/Cable operators in the State to provide services to citizens. Hence it will act as a very critical component in providing the essential services in the State. Accordingly it requires to be designed to have inherent resiliency to provide higher uptime and availability of services for the end users.
3. The proposed network must support scalability to provide continuous growth to meet the growing network requirement.
4. It is important to design and build fibre infrastructure based on standards in order to ensure compatibility, reliability and interoperability of the fibre infrastructure with the systems that use this infrastructure.
5. Factors that affect reliability should be taken into consideration. These include route diversity, redundancy, robustness, security, operation, administration, network management, and maintenance.
6. It should support latest Transmission and Network technologies as well as future technologies in order to avoid obsolescence.
7. The fibre network is to be designed considering the intended technology to be used. The core backbone shall be designed using MPLS on standard IP based network.
8. The Bidder shall provide a detailed document covering design, manufacture, installation, testing and commissioning phases of the project. This shall conform to the key dates given in the Tender Document. It shall include a bar chart of the principal quantities of work forecast for execution monthly.
9. The document shall be made using Project Management software. The Bidder shall also submit soft copy of the document to the Authority for approval.
10. Security must also be provided, since the nodes are extremely important for reliable communications. To ensure secure delivery of services the following minimum safeguards, but not limited, should be considered:
  - a. Kerala Fibre Optic Network is proposed to have a centralized access control mechanism to provide secure access to Network Managers/Engineers at NOC as well as at all the PoP locations.
  - b. The Central Network Management System and appliances are proposed to have authentication, authorization and accounting mechanisms in place.
  - c. The network should have capabilities to filter out undesired and suspicious traffic targeted towards network's control plan.
11. Realistic Capacity Planning required to be done by the bidder for optimizing the proposed solution in order to ascertain right capacities - day 1 and expandability in future.
12. Get the optimized design approved from Authority prior to start of implementation work.
13. Low-level (detailed) design of the NOC meeting the RfP requirements.
14. Identification of Facilities for Establishment of NOC.
15. Preparation of the Functional and System Requirement Specifications for the applications. Preparation of high and low level design document for same.
16. The bidder will appraise the Authority / nominated agency on the optimized design prior to start of implementation work. The bidder will be responsible to optimize design at start and/or in course of implementation in case it is deemed necessary to meet the project objectives.

### **3.3. Setting up of PoPs**

1. Point of Presence (PoPs) shall be created at 378 substations of KSEBL. Successful Bidder after site survey may propose additional PoPs, if required, in each district if the coverage of the substation PoPs within a radius of seven (7) Km are found to be not enough. These locations shall be strategically located at various points across the state after consultation with the Authority. Their configurations shall be equivalent to that of a Spur PoP.
2. For the locations where civil infra is not made available, the bidder will make its own provisioning pre-fabricated structures commonly used for the purpose.
3. The Bidder will conduct necessary site preparation needed for setting up the facility. The bidder shall construct pre-fabricated structure at all the PoPs to erect the required racks, air-conditioning, and redundant power backup, networking equipment and working space. Authority shall provision electricity connection. A proper earthing needs to be provided to all locations.
4. Bidder shall ensure equipment redundancy at all Core PoP locations and power and cooling redundancy at all PoP locations.
5. Bidder should coordinate their work with facilities and electrical personnel to ensure availability of proper space and power (size and AC) to install the terminal equipment and pre-fabricated structures
6. Installation of splice enclosure and splicing of fibre shall be done by the SI. The actual mounting height and location shall be finalised by survey & further advice by Authority during the installation of splice enclosures.

### **3.4. Fibre Laying**

1. Fibre Cable laying for Core, Aggregation and, Pre-Aggregation Rings and last mile connectivity as per the agreed design
2. The SI shall carry out proper tensioning wherever required to maintain the adequate ground clearance and clearance from the live conductor. The detailed installation methodology shall be finalized during the detailed engineering.
3. The scope will cover supply, storage at SI's warehouse, loading, delivery to site, unloading, storing, handling, laying, jointing, installation, testing and commissioning of specified fibre, fittings, its accessories and associated items required as part of implementation
4. SI shall prepare and submit a detailed project implementation plan for the approval by Authority.
5. Site level coordination with KSEBL local substation authorities for carrying out laying work, establishment of PoPs in each substation with local authorities and other agencies, if any, for site access, route access etc. will be necessary.
6. Guidelines for installation of cable is provided in the Tender.
7. The indicative fibre optic cable length requirements are indicated in the BoM and reflected in the Price Schedule for purpose of price discovery. There may be minor variations in the estimated figures and the payment will be linked to actual length commissioned.
8. The SI shall be paid for the actual quantity supplied and installed at site. The measurement for quantity to be paid will be based on horizontal route length of the line and the price quoted by the Bidder shall accordingly consider sag, unequal support heights, wastage, splicing, looping etc.
9. Fibre laying activity has to be carried out for both the Packages. For Package A, the cable shall be installed on 400/220/110/66/33 KV Lines and HT/LT distribution lines. Map for the core network of Package A is given as part of this Tender. However, SI shall verify these routes during the survey and submit the site survey report and final BoQ.
10. Four types of fibre cable is being procured under Package A:-
  - a. OPGW for transmission lines of capacities 66kV and above.
  - b. ADSS for 33 kV and HT/LT distribution poles. The ADSS specifications for HT and LT will be suitably chosen to meet the expected service levels.
  - c. Drop cable for last mile connectivity



## Volume- II

---

- d. Underground cable, for cases where aerial mode is not possible and underground approach cable in the substations
11. The link data prepared by Authority for Package A contains the following attributes:
  - a. District
  - b. Tier Type (Core/Aggregation/Pre-Aggregation/Spur/ Redundant connection for Spur)
  - c. Link name (From\_To)
  - d. KV Type (400/220/110/66/33/Distribution Line(DL))
  - e. Length (link length in km)
  - f. Implementation Type (Upgradation, Transgrid Phase 1, Transgrid Phase II, KFON, PSDF, 33kV, DL)
12. OPGW cable shall be laid on links under Implementation type KFON & PSDF, ADSS over links under 33kV & DL. For the links under Implementation type Upgradation/Transgrid I/Transgrid II, if the existing towers/transmission circuits are subject to any upgradation an alternate route through any HT/LT/distribution lines may be considered and ADSS cable shall be used for those. PSDF would mean that link is under Package B
13. There may be overlap between rings
14. For access network, SI shall do the site survey, prepare the GIS route maps and submit the final BoQ. List of horizontal offices to be connected shall be provided to the Successful Bidder.
15. Based on the submitted list of the links to be connected, Authority shall obtain ROW clearances
16. Fibre cables (OPGW/ADSS) already laid on transmission lines by KSEBL will be used to connect to the rings to an extent wherever possible based on the availability of fibre cores in the existing network and field conditions. The details / location of such OPGW cable will be provided by the Authority during the execution of the works.
17. The installation shall be generally in accordance with the latest version of IEEE Guide to the Installation of overhead transmission line conductor with additional instructions and precautions for live line working and fibre optic cable handling
18. The Authority assumes that the SI is aware of any and all risks associated with this project. Under this assumption the Authority considers itself indemnified against any and all charges/legal proceedings for any accidents associated with the project. The Client will however extend any reasonably possible help.
19. The SI and the Authority shall establish and agree to a system for ensuring the safety of personnel and equipment. The SI shall be primarily responsible for the safety precautions.
20. All the workers shall be supplied with appropriate personal protective equipment (e.g., safety helmet, safety glasses, protective gloves and boots etc.) and tools where applicable to allow them to perform their work safely, maintain equipment in good working condition, and operate equipment in accordance with the manufacturers' recommendations
21. All safety equipment such as safety belts, insulating and cotton gloves and hard hats, fluorescent vests etc. as required.
22. Selection of the specific technique (i.e. Moving Drum method, Stationary Drum method or Manual Installation method), or a combination thereof, shall largely depend on the actual site conditions. The SI shall select the most appropriate installation technique suitable to the site conditions studied during the survey.
23. The SI shall facilitate hands-on-training and handling of special tools and tackles, as relevant to the engineers and line staffs during site installation. The cost associated with such hands-on training during at project site will be deemed to have been included in the overall price of the Contract.
24. The SI shall submit to the Authority a fortnightly work plan detailing for each portion of the works separately, the numbers of the various classes of workmen deployed by him on the site, the SI's equipment on site, or any other information that may reasonably be required.
25. Access to the SI's and its Sub-Contractor's works shall be granted to the Authority at all reasonable times for the purpose of ascertaining progress.

26. Analysis shall be carried out by the bidder to ensure that with the stringing of OF cable, the pole remains stable as per the relevant standards.
27. The successful bidder is required to provide pole strengthening mechanisms such as cross arms, pole stays/guys etc. to ensure that the safety of the existing power infrastructure is not compromised. This requirement has not been reflected as a separate item in the price schedule and therefore any costs associated with it should be included in the item price of other items included in the price schedule.
28. The color-coding and naming convention for OFC cable shall be as mentioned in this Tender document.
29. During the course of installation, if any utility services or roads or other assets of the Government or third party assets etc. are damaged, then the SI has to repair and reinstate the same at his own cost.
30. SI shall prepare As-Built-Drawings (ABD) of laid OFC and upload them to central servers at NOC
31. SI shall provision a fibre monitoring tool to monitor the health of the fibres. The Solution should be able to monitor fibres from Core location through Aggregation, Pre-Aggregation, Spur and till Street Box/Enclosure.

### **3.5. Commissioning of Electronic Equipment**

SI shall be responsible for the procurement, supply, installation, testing, commissioning and acceptance of OFC, Equipment and accessories. These are listed below:

1. Delivery of OFC, equipment (active and passive), accessories and testing tools at SI's warehouses (to be informed to Authority)
2. Ensuring collection and placement of fault material at the warehouse
3. Transport and Delivery of equipment at site location - Substation and others as agreed with Authority
4. Installation of equipment at site location
5. Maintaining warehouse records as per agreed procedures
6. Storing material at site
7. Upkeep and safety of material till commissioning
8. Provisioning of equipment for photography to take site images at designated locations and images of the testing procedures carried out
9. Obtain commissioning certificate
10. Necessary testing equipment required to meet standards compliance will be provided by the SI. After completion of the testing for each site, bidder need to submit the report in prescribed format to the Authority. Authority or its nominated agency will use the equipment to validate the reports submitted by the SI.
11. Necessary coordination with local authorities and other agencies, if any, for site access, route access etc. during commissioning.

### **3.6. Network Operating Centre (NOC)**

A Central IT infrastructure will be required to centrally monitor, control and manage the network. This comprises establishment of Network Operations Centre (NOC), development and deployment of Enterprise Management System (EMS) including SLA monitoring, Server performance monitoring, Network and Helpdesk Management System. The required solution shall be hosted in the servers procured for this project and placed at the NOC.

The proposed State NOC shall have the required IT and Non-IT infrastructure. The brief outline of the requirements are presented below

1. The location of the NOC shall be communicated to the Successful Bidder.. Authority shall make arrangement for the required space and electricity for setting up of NOC.
2. SI needs to survey the site; design the layout of the site including all the standard furnishings etc. to make the NOC operations.
3. NOC shall act as centralized management of full-network resource and service inventory to improve utilization of in-service resources.



## Volume- II

---

4. The detailed space requirements for NOC is provided under the section Operational Facilities Requirements.
5. SI shall provide and do all the electrical cabling including industrial sockets, PDUs, passive components like patch panel, LIU, patch cords in all the racks provisioned in the server room.
6. The Network Operating Centre will be linked to the NOC of KSWAN and SDC 1 & SDC 2 to route the Government traffic.
7. The NOC will house the Enterprise Management System solution to monitor the complete IP network (All the active devices, any other SNMP enabled devices in the network, IT systems in the NOC) and optical network.
8. The NOC will have the CRM solution required for the basic billing and accounting for selling bulk bandwidth and leasing dark fibre.
9. The IT infrastructure will be in full redundancy architecture and will be provisioned with the required storage, computing, networking, security backup, monitoring and management, help desk components.
10. SI will be responsible for the supply of the application and licenses (perpetual) of related software products and installation, configuration & commission of the same so as to meet project requirements.
11. All licenses shall be in the name of the Authority. SI shall have provision for procurement of licenses in a staggered manner as per the actual requirement of the project.
12. The SI shall perform periodic audits to measure license compliance against the number of valid End User software licenses consistent with the terms and conditions of license agreements, volume purchase agreements, and other mutually agreed upon licensed software terms and conditions.
13. The SI shall report any exceptions to license terms and conditions at the right time to Authority. However, the responsibility of license compliance solely lies with the SI. Any financial penalty imposed on Authority during the contract period due to license non-compliance shall be borne by SI. SI shall also supply any other tools & accessories required to make the integrated solution (if any) complete and up -to-date as per requirements.
  - a. For the integrated solution, the SI shall supply:
  - b. Software & licenses
14. Supply tools, accessories, documentation and provide a list of the same. Tools and accessories shall be part of the solution.
15. The Non-IT infrastructure shall cover site preparation, electrical works, DG, UPS for server farm, UPS for help desk, PAC for server farm area, comfort ACs for other areas, safety and security devices such as Access control, fire suppression, fire detection, water leakage detector, rodent control, CCTV and BMS, etc.
16. The complete BOQ of the work to be done at NOC needs to be submitted along with the design and approval to be taken from the Authority before start of the work.
17. SI shall provision a video wall for efficient monitoring and management of the entire network
18. NOC shall have a centralized monitoring console displaying network topology map. It shall provide key correlation analysis for network fault processing to improve network fault processing efficiency, provide performance & trend analysis of network equipment and impact range of network fault, network usage, availability and performance for server nodes. etc.
19. SI shall ensure sufficient qualified man power for NOC operations. NOC shall be managed 24x7x365 and accordingly manpower shall be planned by the SI. NOC shall always be able to generate inventory report of active elements like port status, port utilization status etc. for future perspective through Network Management System (NMS). NOC would also maintain necessary reports like details of no. of nodes per logical links on any particular fibre route through NMS
20. System Documentation both in hard copy and soft copy to be supplied along with licenses and shall include but not limited to following. Documentation to be maintained, updated and submitted to Authority regularly:
  - a. Functional Requirement Specification (FRS)
  - b. High level design of whole system
  - c. Low Level design for whole system / Module design level

- d. System Requirements Specifications (SRS)
- e. Any other explanatory notes about system
- f. Traceability matrix
- g. Technical and product related manuals
- h. Installation guides
- i. User manuals
- j. System administrator manuals
- k. Toolkit guides and troubleshooting guides
- l. Other documents / reports as prescribed by Authority
- m. Quality assurance procedures
- n. Change management histories
- o. Version control data
- p. SOPs, procedures, policies, processes etc. developed for Authority
- q. Programs :
  - i. All programs must have explanatory notes for understanding
  - ii. Version control mechanism
  - iii. Old versions to be maintained

### **3.7. Last Mile Connectivity**

Government of Kerala also intends to provide last mile optical fibre connectivity through KFON to the government and educational institutions (Departments/schools/hospitals etc.), including the supply of Customer Premise Equipment (CPE) to enable the intended services such as data and video services. The details of the last mile offices to be connected will be provided to the Successful Bidder. The Bidder, in this regard, will have following responsibilities.

1. Survey of location to decide space and size for installation of termination boxes, ONTs etc. Power availability points and cabling requirement to these equipment.
2. Geographical coverage shall be noted by the bidder
3. Last mile optical fibre connectivity of ONT with its OLT
4. Supply, installation and configuration of the equipment with proper grounding.
5. Providing O&M support in case of service failure as per defined SLA.
6. Any other which is necessary for this service
7. The internet bandwidth provision is not in the scope of SI. The internet bandwidth will be procured from the separate vendor. However, the SI is required to ensure the distribution of internet bandwidth to locations covered under this Tender by configuration and monitoring of the devices supplied as part of this RfP at the central locations.

### **3.8. Preparation and Implementation of Information Security Policy**

The Successful Bidder shall prepare the Information Security Policy for the overall Project and the same would be reviewed and then finalized by the Authority and its authorized committee(s). The Security policy needs to be submitted by the Systems Integrator within 1st quarter of the successful Final Acceptance Tests.

The Systems Integrator should then obtain ISO 27001 certification for the NOC within 2 quarters of Final Acceptance Test of the NOC. Payment from 3rd Quarter onwards shall be withheld till this certification is obtained by the Successful Bidder.

### **3.9. Suggestions on Network Upgrade**

As we are aware, constant changes / updates happen in technology, and it is very important that the Network System implemented by the Authority keeps its pace with the technology. Authority would want the Successful Bidder to submit a report, every 6 months, on the advancements available in technology to make the best use of the existing infrastructure. In this report, the SI can suggest certain improvements in the system to make the operations more effective. Any upgradation / augmentation suggested by the SI would be analysed by the Authority and appropriate decision would be taken. After "Go-Live" the major modifications or additions in the system shall be done through change management requests.

## **4. Network Design Considerations for KFON**

### **4.1. General Guidelines**

1. A telecom grade network design is proposed for Kerala Fibre Optic Network. The overall network is designed considering the critical network design parameters i.e. Scalability, Security, Manageability, Reliability, Interoperability and Resiliency requirements. The following parameters shall be considered while designing the state wide fibre network.
2. The core network shall be created with required redundancy. Hence a ring architecture shall be the choice for the network topology.
3. All rings shall be created by using transmission routes to the extent possible. In case ring closure is not feasible through transmission circuits, it shall be done through distribution poles.
4. In order to ensure redundancy for Spur PoPs, path through transmission poles shall be traced for Spur PoPs first, in case of non-availability distribution poles as a redundant route to the transmission circuit route.
5. It is proposed that DWDM may be used as transport network technology for the network segment.
6. The Core PoP connected to NOC shall be on a dedicated fibre connection
7. Layer-3 IP-MPLS appliances are proposed to be deployed in core ring
8. Fibre monitoring system shall be deployed at all core PoP locations to monitor the fibre network from core locations till network at street box.
9. It is proposed that the core network components may support SDN capabilities and other emerging new technology.
10. SI shall ensure that network design and implementation must be free of any SPOF (Single Point of Failure) from perspective of both active and passive elements. Considering the scope set in this Tender, the SI shall carefully consider the solutions it proposes and explicitly mention the same in the technical proposal
11. Wherever required, optical line amplifiers shall be installed on the same cable at the appropriate distances considering the line losses.
12. Cable loops are to be provided for future maintenance purposes at regular spacing.

### **4.2. Core Ring**

1. The ring will interconnect all the 14 Tier 1 substations with NOC and SDC. There shall be more than one ring.
2. The core backbone ring topology shall be constructed using over-head 48 Core Optical Fibre Cable.
3. This ring will carry all the traffic from each district to the NOC, Data Centre as well as each district to district. The core ring shall be designed to drop approx. 40 Gbps traffic at each district node.
4. It will deploy high end scalable routers and will be running IP/MPLS protocols.

### **4.3. Aggregation Ring**

1. The Aggregation rings shall be constructed using 48 Core Optical Fibre Cables

2. Aggregation layer will deploy high end scalable routers and should act as service edge layer for insertion of any kind of services (native L2, L3, MPLS VPN, Multicast etc).. Aggregation Layer will aggregate traffic from pre-aggregation and will be connected to core router.
3. Ring shall utilize a 40 Gigabit Ethernet / optical technology

**4.4. Pre- Aggregation Ring**

1. The PA ring shall be constructed using a 48 Core Optical Fibre Cables
2. The ring shall utilize a 20 Gigabit Ethernet / optical technology
3. Pre- Aggregation layer will deploy high end scalable routers and should act as service edge layer for insertion of any kind of services (native L2, L3, MPLS VPN, Multicast etc). The capacity will be multiples of 10G which can be further scaled as the traffic grows.

**4.5. Last Mile Connectivity**

1. Horizontal connectivity to the Government and educational institutions shall be through a passive optical fibre network
2. It shall use a single-mode fibre connecting optical line terminal (OLT) through one or more passive optical splitters to multiple end points called optical network terminals (ONTs)
3. OLTs shall be placed at the PoPs of core network and ONTs at the Government and educational institutions. Optical splitter shall be placed at strategic locations decided after the survey

**5.Functional Requirements**

**5.1. Functional Requirements for Core Network**

SL No.	Parameter	Requirement
1.	General	<ul style="list-style-type: none"> <li>ξ The network should support successful implementation of Broadband, e-Education (Virtual and Digital),WiFi, and other state wide network initiatives.</li> <li>ξ The network should be built to provide the following:                             <ul style="list-style-type: none"> <li><input type="checkbox"/> Higher Network Uptime</li> <li><input type="checkbox"/> Complete Centralised Visibility of Network (All the four layers)</li> <li><input type="checkbox"/> Better Utilization of WAN Links</li> <li><input type="checkbox"/> Segregation of Traffic and QOS in line with Industry standards</li> <li><input type="checkbox"/> Better Network Management (Provisioning, Activation, Fault, Performance etc)</li> </ul> </li> <li>ξ The network should have the capability and facility for Seamless integration with all other component required to build a digital backhaul for state.</li> <li>ξ Network Should act as backbone for all the state services (Layer 2 or layer 3) which may come in future</li> <li>ξ Network must support next generation architecture to support future application like Voice, Video, Wi-Fi etc.</li> </ul>

**Volume- II**

SL No.	Parameter	Requirement
		<p>ξ Network must be connected in Ring fashion and devices must support the dynamic redundancy protocol for better convergence.</p> <p>ξ The Ring Based architecture must be deployed to meet the following :</p> <ul style="list-style-type: none"> <li><input type="checkbox"/> Redundancy of nodes and Links</li> <li><input type="checkbox"/> Less prone to failures</li> <li><input type="checkbox"/> Better Link utilization</li> <li><input type="checkbox"/> Traffic will not hog core bandwidth for any to any communication</li> <li><input type="checkbox"/> Easy Insertion of new Node. No configuration change at Core</li> </ul> <p>ξ Network must support Node and Link protection feature for faster and reliable network convergence.</p> <p>ξ Resource Reservation based Traffic Engineering should be used to Provide the following:</p> <ul style="list-style-type: none"> <li><input type="checkbox"/> Bandwidth guarantee for critical real-time applications in the control plane</li> <li><input type="checkbox"/> Optimized utilization of redundant links</li> <li><input type="checkbox"/> Handling of unanticipated load in the network.</li> <li><input type="checkbox"/> Uneven utilization of links.</li> </ul> <p>ξ Network Convergence methods like Fast Reroute and Bidirectional failure detection must be deployed to achieve faster convergence.</p> <p>ξ Network must support segregation of traffic using Virtual Routing and Forwarding (VRF).</p> <p>ξ QoS enables a network to provide improved service to selected network traffic. The Network must support MPLS QoS features.</p> <p>ξ These nodes should have the capabilities to program the queues in to logical queues to offer multiple services to the end customers.</p> <p>ξ The mapping of QoS should be done on basis of COS, IP prec, TOS, IP address ,VLAN etc.</p> <p>ξ All nodes in network must support Hierarchical Quality of Service for granular QoS.</p> <p>ξ All nodes must support priority queuing (more than one) for assigning more priority to Voice and Video traffic over non critical data traffic.</p> <p>ξ All nodes should act as Service Edge nodes and services can be inserted from that node only.</p> <p>ξ Service edge should be the last node connecting to CPE.</p>

**Volume- II**

SL No.	Parameter	Requirement
		<ul style="list-style-type: none"> <li>§ “Any Service Any Where” with “Enter Anywhere Exit Anywhere” from services and POI (Point of interconnect perspective).</li> <li>§ Service edge Nodes should support layer2 VPN, layer3 VPN,IPTV and multicast VPN. .</li> <li>§ Network should have multicast capabilities and should support at all layers</li> <li>§ Network should have the capability to be used as Backhaul for SWAN and other state networks.</li> <li>§ All service edge nodes must support features to start IPTV and Multicast VPN.</li> <li>§ High QoS, Uptime, Security,L3 ,L2 and Multicast Services from edge where the nodes are connected should be ensured as it will be connecting to MSOs, SP and Telcos.</li> <li>§ 4G and 5G backhaul should be supported at all nodes.</li> <li>§ Packet clock and Sync E should be supported for connecting Telco.</li> <li>§ MPLS NNI (Option-1, 2 and 3) with telecos and other Service providers for traffic exchange at all nodes should be supported.</li> <li>§ Any to any ,one to many, Many to many kind of service should be supported from all nodes</li> <li>§ Interop between OEM for non-vendor locking should be supported at all nodes.</li> <li>§ Integration capabilities with IP/ATM/Frame relay/ TDM’s transport technologies etc.</li> </ul>
2.	Key Features	<ul style="list-style-type: none"> <li>§ All nodes in network must support protocol for management information sharing so that devices can discover and reach to each other.</li> <li>§ Any changes in topology should be automatically learnt by all the devices in network.</li> <li>§ No manual intervention should be required in case of any physical link failure.</li> <li>§ Scalable dynamic protocol should be supported for transferring of customer network information across all service edge devices.</li> </ul>
3.	QoS Architecture	<ul style="list-style-type: none"> <li>§ Low latency Queuing should be deployed to ensure CIR guarantee to all Critical Traffic.</li> <li>§ Minimum 4 Class-of-Service Model should be supported: <ul style="list-style-type: none"> <li>o Mission Critical : Class 1</li> <li>o Business Critical : Class 2</li> <li>o Business Critical Data : Class 3</li> <li>o Best effort : Class 4</li> </ul> </li> <li>§ Matching of traffic should be based on ACL, IPP, DSCP &amp; MPLS EXP</li> </ul>

## Volume- II

SL No.	Parameter	Requirement
		<ul style="list-style-type: none"> <li>§ Marking of traffic Should be based on MPLS EXP</li> <li>§ Should also support weighted random early detection in the network to avoid congestion</li> </ul>
4.	Traffic Engineering Capabilities	<ul style="list-style-type: none"> <li>§ Standard based protocols to automatically map packets onto the appropriate traffic flows should be supported.</li> <li>§ Should Support transport of traffic flows across a network using MPLS forwarding.</li> <li>§ Should support the determination of routes for traffic flows across a network based on the resources the traffic flow requires and the resources available in the network.</li> <li>§ Should Employ "constraint-based routing," in which the path for a traffic flow is the shortest path that meets the resource requirements (constraints) of the traffic flow.</li> <li>§ Should support QoS on Traffic engineering paths or LSPs.</li> <li>§ Should support Recovery of link or node failures that change the topology of the backbone by adapting to a new set of constraints.</li> </ul> <p>Traffic engineering should be used for the following</p> <ul style="list-style-type: none"> <li>§ Providing bandwidth guarantee for critical real-time applications in the control plane</li> <li>§ Optimized utilization of redundant</li> <li>§ Handling of unanticipated load in the network</li> <li>§ Fast reroute to provide fast convergence for critical real-time application traffic.</li> </ul>
5.	MPLS VPN	<ul style="list-style-type: none"> <li>§ All Service edge nodes in network should support : <ul style="list-style-type: none"> <li>o Layer 2 MPLS VPN</li> <li>o Layer 3 MPLS VPN</li> </ul> </li> </ul>
6.	Layer 2 MPLS VPN	<ul style="list-style-type: none"> <li>§ MPLS Transport Should be used for Providing Point to Point and Point to Multipoint VPN services.</li> <li>§ All these Services are in accordance of metro Ethernet Forum and can be broadly categorized as below: <ul style="list-style-type: none"> <li>o Ethernet wire Services</li> <li>o Ethernet relay Services</li> <li>o Ethernet Multipoint Services</li> </ul> </li> </ul>
7.	Layer 3 MPLS VPN	<ul style="list-style-type: none"> <li>§ Layer 3 MPLS VPN can be broadly classified in to : <ul style="list-style-type: none"> <li>o Hub and Spoke VPN</li> <li>o MESH VPN</li> <li>o Extranet VPN</li> </ul> </li> </ul>

SL No.	Parameter	Requirement
		o Multicast VPN.

Table 1: Core network functional requirements

## 5.2. Functional Requirements for NOC

SL No.	Parameter	Requirement
1.	General	<ul style="list-style-type: none"> <li>ξ NOC to be established at Thiruvananthapuram in a space provided by the Authority complying to the best-in-class tier 2 standards.</li> <li>ξ NOC act as centralized management on full-network resource and service inventory to improve utilization of in-service resources.</li> <li>ξ Provide key correlation analysis for network fault processing to improve network fault processing efficiency</li> <li>ξ Provide the function of automatic service design and resource distribution.</li> <li>ξ Provide performance &amp; trend development analysis of network equipment and impact range of network fault and supply end-to-end service quality management &amp; control, which control network &amp; service quality continuously and enhance customer satisfaction</li> <li>ξ Provide FOA (Field Operation Assistance) for field engineers.</li> <li>ξ SI needs to survey the site; design the layout of the site including all the standard furnishings etc. to make the NOC operations. The complete BOQ of the work to be done at NOC needs to be submitted along with the design and approval to be taken from the Authority before start of the work.</li> </ul>
2.	Key Functions	<ul style="list-style-type: none"> <li>ξ Centralized Operation</li> <li>ξ Network performance engagement</li> <li>ξ Planning and Engineering</li> <li>ξ Service management</li> <li>ξ Service provisioning</li> <li>ξ NOC Operation</li> <li>ξ Spare Management</li> </ul>
3.	Field Operations	<ul style="list-style-type: none"> <li>ξ Connectivity</li> <li>ξ IT and Security</li> <li>ξ Provisioning on Field.</li> </ul>
4.	Core Infrastructure	<ul style="list-style-type: none"> <li>ξ MUXs / DWDM / OTN Transmission Infra</li> <li>ξ Capable of connecting to 2 International Internet Gateways</li> </ul>



**Volume- II**

SL No.	Parameter	Requirement
		<ul style="list-style-type: none"> <li>ξ Capable of connecting to 2 National Internet Exchange Gateways</li> <li>ξ Setup IPV6 Network</li> <li>ξ ISP Peering &amp; Up Stream Routers</li> <li>ξ Caching Servers</li> <li>ξ Core Switches for traffic aggregation</li> <li>ξ NMS (Network management system) for equipment's to be monitored. .</li> <li>ξ Network inventory &amp; GIS management system</li> </ul>
5.	ISP peering & Upstream infrastructure	<ul style="list-style-type: none"> <li>ξ Peering &amp; Upstream Routers &amp; Switches to be used the cross connects need to be extended from Meet me room till Network Rack</li> </ul>
6.	Core Routers	<ul style="list-style-type: none"> <li>ξ 2 Core routers operating in High Availability mode</li> </ul>
7.	Core Switches	<ul style="list-style-type: none"> <li>ξ Min 2 Core Switches which will be connected on mesh mode to have high availability.</li> </ul>
8.	Servers	<ul style="list-style-type: none"> <li>ξ All the Servers (CRM, Mail Server , Web Server), &amp; FW devices will be connected to these switches</li> <li>ξ All the servers will be kept in DMZ zone behind Firewalls</li> </ul>
9.	Firewalls	<ul style="list-style-type: none"> <li>ξ Min 4 FWs to be kept and all should be in HA mode, all the servers WEB, Mail , OSS/BSS, CRM, NMS can be kept on DMZ zone.</li> </ul>
10.	AAA	<p>Authentication</p> <ul style="list-style-type: none"> <li>ξ Refers to confirmation that a user who is requesting a service is a valid user.</li> <li>ξ Accomplished via the presentation of an identity and credentials.</li> <li>ξ Examples of credentials include passwords, one-time tokens, digital certificates, and phone numbers (calling/called).</li> </ul> <p>Authorization</p> <ul style="list-style-type: none"> <li>ξ Refers to the granting of specific types of service (including "no service") to the users based on their authentication.</li> <li>ξ May be based on restrictions, for example, time-of-day restrictions, or physical location restrictions, or restrictions against multiple logins by the same user.</li> <li>ξ Examples of services include IP address filtering, address assignment, route assignment, encryption, QoS / differential services, bandwidth control/traffic management, etc.</li> </ul>

SL No.	Parameter	Requirement
		<p>Accounting</p> <ul style="list-style-type: none"> <li>ξ Refers to the tracking of the consumption of network resources by users.</li> <li>ξ Typical information that is gathered in accounting include the identity of the user, the nature of the service delivered, when the service began and when it ended.</li> <li>ξ Used for management, planning, billing, etc.</li> </ul>

Table 2: Functional requirements of NOC

### 5.3. Functional Requirements for GPON

SL No.	Parameter	Requirement
1.	General	<ul style="list-style-type: none"> <li>ξ The FTTx solution should be based on GPON, XG-PON1 / Point-to-Point Active Ethernet</li> <li>ξ GPON should support minimum 2.5G downstream, 1.25G upstream.</li> <li>ξ No. Of Subscribers per GPON port minimum is 64(Splitting ratio 1:64)</li> <li>ξ The system shall be support multiple GbE / 10xGbE network connections.</li> <li>ξ The equipment shall support IPv4 and IPV6. The equipment shall detect the optical power transmission of every ONT, once that it detects some problems in the status of the optical transmission power. The system shall disable the defective ONT automatically in order to guarantee the normally use of the others.</li> <li>ξ Shall support basic OAM features such as loop back, remote diagnostic, CC and Link Trace complies with IEEE 802.1ag.</li> <li>ξ Shall support port-mirroring function for trouble shooting, monitoring, and tracing purpose. The bidder shall explain the port-mirroring function mechanism in detail.</li> </ul>
2.	VLAN	<ul style="list-style-type: none"> <li>ξ Mapping of subscriber VLAN to a common service VLAN</li> <li>ξ Translate/re-write subscribers VLAN ID to another VLAN ID</li> <li>ξ VLAN switching</li> <li>ξ Mapping of the subscriber traffic based on the IEEE 802.1p priority tagging to a specific VLAN.</li> <li>ξ Mapping of the subscriber traffic based on the IEEE 802.1Q VLAN ID to a specific VLAN</li> <li>ξ Mapping of the subscriber traffic based on the combination of IEEE 802.1p and 802.1Q tagging to a specific VLAN</li> </ul>
3.	Subscriber Access Methods	<ul style="list-style-type: none"> <li>ξ DHCP,DHCP option 82/60/43/37/18, Static IP, PPPoE</li> <li>ξ Shall support multiple service delivery of data, voice and video.</li> </ul>

## Volume- II

SL No.	Parameter	Requirement
		<ul style="list-style-type: none"><li>ξ Shall support IP policing at the network and subscriber end.</li><li>ξ Support Ethernet 802.1p and IP TOS bit prioritization.</li><li>ξ The OLTs shall be able to support mobile traffic backhauling.</li></ul>
4.	QoS	<ul style="list-style-type: none"><li>ξ Trusted connectivity where the QoS setting / traffic prioritization configured by customer can be preserved.</li><li>ξ Un-trusted connectivity where the QoS setting / traffic prioritization configured by customer can be overwritten by the Equipment.</li><li>ξ Shall support Dynamic Bandwidth Allocation (DBA) mechanism to allow optimum bandwidth utilization on each PON interface. The detail implementation and capability of DBA mechanism should be explained in detail.</li></ul>

*Table 3: Functional requirements for access layer*

## 6. Common Guidelines Regarding Compliance of Equipment

- § The specifications mentioned for various IT / Non-IT components are indicative requirements and should be treated for benchmarking purpose only. Bidders are required to undertake their own requirement analysis and may propose higher specifications that are better suited to the requirements.
- § Any manufacturer and product name mentioned in the Tender should not be treated as a recommendation of the manufacturer / product.
- § None of the IT / Non-IT equipment proposed by the Bidder should be End of Life product. It is essential that the technical proposal is accompanied by the OEM certificate in the format given in Volume I of this Tender, wherein the OEM will certify that the product is not end of life product and shall support for at least 7 years from the date of Bid submission.
- § All IT components should support IPv4 and IPv6.
- § Technical Bid should be accompanied by OEM's product brochure / datasheet. Bidders should provide complete make, model, part numbers and sub-part numbers for all equipment/software quoted, in the Technical Bid.
- § Bidders should ensure complete warranty and support for all equipment from OEMs. All the back-to-back service agreements with respective OEMs should be submitted along with the Technical Bid.
- § All equipment, parts should be original and new.
- § The user interface of the system should be a user friendly Graphical User Interface (GUI).
- § Critical core components of the system should not have any requirements to have proprietary platforms and should conform to open standards.
- § For custom made modules, industry standards and norms should be adhered to for coding during application development to make debugging and maintenance easier. Object oriented programming methodology must be followed to facilitate sharing, componentizing and multiple-use of standard code. Before hosting the application, it shall be subjected to application security audit (by any of the CERTIN empanelled vendors) to ensure that the application is free from any vulnerability and approved by the Authority.
- § All the Clients Machines / Servers shall support static assigned IP addresses or shall obtain IP addresses from a DNS/DHCP server.
- § The Successful Bidder should also propose the specifications of any additional servers / other hardware, if required for the system.
- § All IP MPLS routers shall be from same OEM.
- § The Servers provided should meet industry standard performance parameters (such as CPU Utilisation of 60 percent or less, disk utilisation of 75 percent or less). In case any non-standard computing environment is proposed, detail clarification needs to be provided in form of supporting documents, to confirm (a) how the sizing has been arrived at and (b) how SLAs would be met.
- § SI is required to ensure that there is no choking point / bottleneck anywhere in the system (end-to-end) and enforce performance and adherence to SLAs. SLA reports must be submitted quarterly/as specified in the Bid without fail.

## Volume- II

- ξ All the hardware and software supplied should be from an Original Equipment Manufacturers (OEMs). Authority reserves the right to ask replacement of any hardware / software if it is not from a reputed brand and does not conform to all the requirements specified in the tender documents.
- ξ System Integrator shall place orders on various OEMs directly and not through any sub-contractor / partner.
- ξ All licenses should be in the name of the Authority.

## 7. Bill of Material

### 7.1. Bill of Material for Package A

#	Item	UoM	Total Qty
1	2	3	4
<b>FIBER &amp; ACCESSORIES</b>			
<b>A. OPGW Cable &amp; Accessories</b>			
1	48F DWSM OPGW fiber optic cable	Km	516
2	Installation hardware set for the above 48F OPGW fiber optic cable including all cable fittings, accessories	Set	516
3	Joint Box	Nos	259
<b>B Installation, Commissioning &amp; Testing for OPGW Installation</b>			
1	Survey of route, design and submission of drawing for approval and detailed list of materials required for the work and providing as built drawing after the execution of work.	Km	516
2	Installation of 48 Fiber (DWSM) OPGW optic fiber cable on transmission tower, fixing of hardware set, cable fittings and accessories and installation of joint boxes and its terminations etc.	Km	516
3	Splicing and installation of Joint Boxes	Set	259
4	End to End testing of OPGW and approach cable and accessories	Km	516
<b>C. OF Cable &amp; Accessories</b>			
1	48F ADSS fiber optic cable with 100 Kmph	Km	14,886
2	48F ADSS fiber optic cable with 150 Kmph	Km	10,097
3	24F ADSS fiber optic cable	Km	10,250
4	12F ADSS fiber optic cable	Km	7,409
5	Anchoring / tensioning clamp assembly for the poles	No	639,630
6	Suspension clamp assembly	No	426,420
7	Adjustable Cable Storage Bracket	No	170,568
8	Down Lead Clamps Assembly	No	170,568
9	48F UG fiber optic cable	Km	600
10	PLB HDPE pipe	Km	600
11	RCC route indicators	No.	3,000
12	Man holes	No.	300
13	4F fiber optic drop cable	Km	6,088

**Volume- II**

#	Item	UoM	Total Qty
1	2	3	4
14	Anchoring / tensioning clamp assembly for the poles	No	91,320
15	Suspension clamp assembly	No	60,880
16	Adjustable Cable Storage Bracket	No	24,352
17	Down Lead Clamps Assembly	No	24,352
18	Anchoring bolt	No	30,438
19	Street Box Type I - (Branch Joint Closure)	No.	29,241
20	Street Box Type II - (FTB Type II)	No.	6,088
21	FTB Type I at end office	No.	30,438
22	1:4 optical splitter	No.	13,049
23	1:8 optical splitter	No.	2,039
24	Poles and accessories	No	5,000
<b>D. Installation, Commissioning &amp; Testing for OFC &amp; accessories</b>			
1	Survey of route, design and submission of drawing for approval and detailed list of materials required for the work and providing as built drawing after the execution of work	Km	49,330
2	Installation of 48FADSS optic fiber cable, fixing of hardware set, cable fittings, accessories, joint closures, FTB, splicing and terminations etc.	Km	24,983
3	Installation of 24FADSS optic fiber cable, fixing of hardware set, cable fittings, accessories, joint closures, FTB, splicing and terminations etc.	Km	10,250
4	Installation of 12FADSS optic fiber cable, fixing of hardware set, cable fittings, accessories, joint closures, FTB, splicing and terminations etc.	Km	7,409
5	Excavation of trench for PLB laying, PLB laying, back filling, reinstatement and compaction, laying of 48 F UG optical fiber cable, its splicing and terminations etc. and all other allied activities	Km	600
6	Installation of 4FADSS optic fiber cable, fixing of hardware set, cable fittings, accessories, joint closures, FTB, splicing and terminations etc.	Km	6,088
7	End to End testing of total OFC and accessories	Km	49,330
8	Installation of Poles and accessories	Nos	5,000
<b>IT &amp; NON - IT</b>			
<b>A. NOC-Non IT</b>			
1	Civil works including site preparation and partitioning works, false flooring, false ceiling, floor strengthening, etc.	Site	1
2	Electrical works including light fixtures, cabling, panels + Earthing etc.	Site	1
3	250 KVA DG set with AMF Panel and required foundation and civil structure	No.	2
4	Precision AC for server room	Lot.	1
5	Comfort AC for NOC, UPS, BMS, Meeting, electrical rooms, etc.	Lot.	1

**Volume- II**

#	Item	UoM	Total Qty
1	2	3	4
6	80 kVA online UPS (with SNMP) with 30 minutes battery backup and battery enclosure for server farm area	No.	2
7	30 kVA online UPS (with SNMP) with 30 minutes battery backup and battery enclosure for help desk and other areas	No.	2
8	Access Control System (RFID + Biometric, smart cards) to manage NOC and all the PoP locations	Set	1
9	High Sensitivity Smoke Detection System	Set	1
10	Fire Detection System	Set	1
11	Fire Suppression System	Set	1
12	Indoor Dome Camera	Lot.	1
13	Rodent Repellent System	Set	1
14	Water Leak Detection System	Set	1
15	Integrated Building Management Solution	Set	1
16	42U Network Racks installed with redundant PDUs, Industrial sockets and accessories	No.	4
17	42U Server Racks installed with redundant PDUs, Industrial sockets and accessories	No.	16
18	LCD Projector	No.	1
19	70" LED TV	No.	3
20	Network Colour Laser Printer	No.	1
21	Network MFP	No	1
22	Passive Items	Lot.	1
23	Workstation Furniture and Fixtures including chairs	Set	20
24	Conference Table (for 10 personnel) & Chairs	Set	1
25	Public Addressable System	Set	1
<b>B. NOC - IT components</b>			
1	IP MPLS Router	No.	2
2	Internet router	No.	2
3	URL Filtering Firewall	No.	2
4	DC Firewall	No.	2
5	DC Core Switch	No.	2
6	Access Switch	No.	4
7	Aggregation Switch	No.	2
8	SAN storage (80 TB) for application & DB	Set	1
9	Video storage (200 TB)	Set	1
10	SAN Switch	No.	2
11	Secondary Storage	Set	1
12	Blade Chassis	Set	1
13	Servers	Lot.	1

**Volume- II**

#	Item	UoM	Total Qty
1	2	3	4
14	OS licenses	Lot.	1
15	DB licenses	Lot.	1
16	Virtualization software license	Lot.	1
17	Workstation computers	No.	5
18	Desktop Computers	No.	15
19	IP phones	No.	20
20	IP PBX	No.	2
21	Voice Router	No.	2
22	Video Management System base license	Lot.	1
23	Video Management System camera license	No.	400
24	Video wall display, Controller, Video wall Management Software & Accessories	Set	1
25	Link load balancer	No.	2
26	KVM switch (If Required)	No.	2
27	Backup and archival solution	Lot.	1
28	EMS solution for Network(for MPLS & DWDM) with NMS	Lot.	1
29	EMS solution for GPON with NMS	Lot.	1
30	BSS software including CRM, Enterprise & Partner billing module, and self-care portal	Lot.	1
31	Anti-virus software	Lot.	1
32	GIS software license	Lot.	1
33	Fibre Monitoring System	Lot.	1
34	Centralized Access Control system software	Lot.	1
35	Project Management Software	Lot.	1
<b>C. Core PoP</b>			
1	Modular MPLS Router	No.	28
2	24 port Access Switch	No.	14
3	Desktop Computers	No.	14
4	IP phones	No.	14
5	High Density Fiber Distribution Frame	No.	14
6	15 kVA UPS (with SNMP) with 30 minutes battery back up and battery enclosure	No.	28
7	42U server racks installed with redundant PDUs, Industrial sockets and accessories	No.	28
8	Split Air Conditioners 3 TR with timer	Nos	42
9	Pre-fabricated Shelter	Set	14
10	Indoor CCTV Dome Camera	No	14
11	Indoor CAT 6 patch cord 10 mtr	No.	28



#	Item	UoM	Total Qty
1	2	3	4
12	Access Control system with Biometric + Smart card Reader & Smart Card, Push button, Magnetic lock and accessories	Set	14
13	Fibre monitoring unit with minimum of 4 ports and scalable to 8 ports	No.	14
14	Spare Cable Box	No.	14
15	Passive Cabling & Accessories	Lot.	14
16	Site Preparation( partition for UPS, exhaust fan, painting, light & fans) and Electrical works including earthing	site	14
<b>D. Aggregation PoP</b>			
1	Modular MPLS Router	No.	87
2	24 port Access Switch	No.	87
3	High Density Fiber Distribution Frame	No.	87
4	5 kVA UPS (with SNMP) with 30 minutes battery back up and battery enclosure	No.	174
5	42U server Racks installed with redundant PDUs, Industrial sockets and accessories	No.	87
6	Split Air Conditioners – 2 TR with timer	Nos	174
7	Pre-fabricated Shelter	Set	87
8	Indoor CCTV Dome Camera	No	87
9	Indoor CAT 6 patch cord 10 mtr.	No.	174
10	Access Control system with Biometric + Smart card Reader & Smart Card, Push button, Magnetic lock and accessories	Set	87
11	Spare Cable Box	No.	87
12	Passive Cabling & Accessories	Lot.	87
13	Site Preparation( partition for UPS, exhaust fan, painting, light & fans) and Electrical works including earthing	site	87
<b>E. Pre- Aggregation PoP</b>			
1	IP MPLS Router	No.	194
2	24 port Access Switch	No.	194
3	High Density Fiber Distribution Frame	No.	194
4	5 kVA UPS (with SNMP) with 30 minutes battery backup and battery enclosure	No.	388
5	42U server Racks installed with redundant PDUs, Industrial sockets and accessories	No.	194
6	Split Air Conditioners – 2 TR with timer	No.	388
7	Pre-fabricated Shelter	Set	194
8	Indoor CCTV Dome Camera	No	194
9	Indoor CAT 6 patch cord 10 mtr.	No.	388
10	Access Control system with Biometric + Smart card Reader & Smart Card, Push button, Magnetic lock and accessories	Set	194
11	Spare Cable Box	No.	194

**Volume- II**

#	Item	UoM	Total Qty
1	2	3	4
12	Passive Cabling & Accessories	Lot.	194
13	Site Preparation( partition for UPS, exhaust fan, painting, light & fans) and Electrical works including earthing	site	194
<b>F. Spur PoP</b>			
1	IP MPLS Router	No.	83
2	24 port Access Switch	No.	83
3	High Density Fiber Distribution Frame	No.	83
4	3 kVA UPS (with SNMP) with 30 minutes battery backup and battery enclosure	No.	166
5	42U server Racks installed with redundant PDUs, Industrial sockets and accessories	No.	83
6	Split Air Conditioners – 2 TR with timer	No.	166
7	Pre-fabricated Shelter	Set	83
8	Indoor CCTV Dome Camera	No	166
9	Indoor CAT 6 patch cord 10 mtr.	No.	83
10	Access Control system with Biometric + Smart card Reader & Smart Card, Push button, Magnetic lock and accessories	Set	83
11	Spare Cable Box	No.	83
12	Passive Cabling & Accessories	Lot.	83
13	Site Preparation(partition for UPS, exhaust fan, painting, light & fans) and Electrical works including earthing	site	83
<b>G OLT</b>			
1	4 port GPON OLT (at PoP location)	No.	94
2	8 port GPON OLT (at PoP location)	No.	284
<b>H. DWDM Solution</b>			
1	DWDM Solution at NOC and all Core PoP locations	No.	14
<b>I. End Office</b>			
1	300 VA UPS with 30 min Battery backup to be supplied along with the enclosure	No.	30,438
2	2x5 way 10 amp PDU	No.	30,438
3	9U Network Rack 19" with provision to mount the ONT	No.	30,438
4	GPON ONT (at end office)	No.	30,438
<b>J. Installation, Commissioning &amp; Testing</b>			
1	Installation, Commissioning & Testing of all IT/Non IT Components at NOC	Set	1
2	Installation, Commissioning & Testing of all IT/Non IT Components at Core PoPs incl. OLT	Set	14
3	Installation, Commissioning & Testing of all IT/Non IT Components at Aggregation PoPs incl. OLT	Set	87

**Volume- II**

#	Item	UoM	Total Qty
1	2	3	4
4	Installation, Commissioning & Testing of all IT/Non IT Components at Pre-Aggregation PoPs incl. OLT	Set	194
5	Installation, Commissioning & Testing of all IT/Non IT Components at Spur PoPs incl. OLT	Set	83
6	Installation, Commissioning & Testing of DWDM equipment at all Core PoPs & NOC	Set	1
7	Installation, Commissioning & Testing of all IT/Non IT Components at end offices	Set	30,438
<b>K. Others</b>			
1	Training	Lot.	1

*Table 4: Core and Access Networks*

## SECTION II

***Package - Providing Reliable Communication and Data Acquisition System to all Substations of and above 110kV Voltage Level***

## 1. Introduction

This section of Tender Document describes the overview of Package B and the technical specifications for OPGW which includes overhead fibre optic cable (OPGW 48 fibre), fibre optic approach cable and associated hardware fittings. The intend of this project is to implement a fibre optic connectivity to 250 numbers Substation of and above 110kV level across Kerala State for providing reliable communication as a part of Power System Development project.

The purpose of this section of the specification is to provide general information about the package, general requirements, responsibilities and obligations of the SI as well as KSEBL and general bidding requirements.

### 1.1. Project Overview

Power System in the country is expanding very fast and with increased number of interconnections between States/Regions, many new technologies are being implemented for ensuring minimum grid disturbances. The new technological requirements of Power System Operations are Special Protection Scheme, Grid Security Expert System, Load Management, Advanced Protection System, Substation Automation System etc.

For implementing these new technological requirements a wide band system based on optical fibre is essential.

At present KSEBL has a fibre optic backbone network connecting major 220kV and 110kV Substations from Kasaragod to Thiruvananthapuram. This network consists of around 600Kms (including under construction) of ADSS and OPGW fibre optic cables.

KSEBL is now planning to connect 250 numbers Substations and Generating Stations of and above 110kV Voltage level for reliable communication with Optical fibre cable (**OPGW 48 fibres**) per the recommendation of Central Electricity Authority (CEA) under PSDF assistance.

### 1.2. Existing Communication System

The existing wide band communication system of KSEBL comprises of fibre optic links supporting bit rate of STM-4. The wide band communication network is providing voice and data connectivity among control centers and from RTU to control centers. The fibre optic links are working along with PDH equipment (primary multiplexers). The subscribers are connected to the PDH equipment and voice/data channels are working.

Proposed Communication System shall be fibre optic based and shall consist of overhead and underground fibre optic cables. The scope of the Optic Fibre link for the project includes design, supply, installation, testing and implementation of Optic Fibre network consisting of overhead and underground fibre optic systems terminating in FODPs to be installed at KSEBL Substations.

### 1.3. Scope of Work

The broad scope of the procurement of this part include survey, planning, design, engineering, manufacturing, supply, transportation, insurance, delivery at site, unloading, handling, storage, supervision of erection/installation, splicing, termination, testing, and demonstration for acceptance, commissioning and documentation for:

- a) OPGW fibre optic cable including all associated hardware, accessories and fittings.
- b) Fibre optic approach cable including all associated hardware, accessories, fittings required for the installation of approach cable.
- c) Permanently lubricated High Density Poly Ethylene (PLB HDPE) pipe, GI pipes required for installation of approach FO cable.
- d) Fibre Optic Distribution Panels (FODP) and joint box.
- e) Supervision of erection/installation of OPGW.

## Volume- II

---

- f) Splicing of fibres.
- g) Supply of spares/ test equipment (BoQ provides only the Mandatory/Minimum Spares. The SI shall supply at the end of the project completion period).

The SI shall be responsible for all cables and hardware provided both inside and outside buildings in accordance with technical specifications. SI's obligations include, but are not limited to, the following:

- § Engineering and design specific to each location including review of and conformance with local environmental requirements.
- § Input for finalization of installation and safety guidelines and procedures for the stringing, mechanical installation as required.
- § Site visits, path surveys, and studies necessary to identify and provide all equipment needed to implement the FO cables installation.
- § Connectivity between FODP and approach cable.
- § Implement all minor civil works and identify any major civil works i.e. expansion or Construction of trenches necessary for installation of proposed OFC and for fixing FODP.
- § All hardware required to satisfy the requirements of this specification.
- § Factory and site testing of all hardware and accessories provided.
- § Provide documented evidence of satisfactory type test performance to the KSEBL and if required by the KSEBL conduct type test.
- § Provide a quality assurance plan ensuring the KSEBL access to the manufacturing process.
- § Shipment of all equipment and documentation to the KSEBL designated locations and/or storage areas.
- § Storage, maintenance of storage area and security including full responsibility for protection from theft and fire.
- § Hardware, and firmware maintenance through final acceptance and maintenance on all new links through the guarantee period.
- § Assessment of suitability for live line installation of overhead FO cable on the present infrastructure, towers etc.
- § Design and Installation of the mechanical assemblies and accessories, including vibration dampers required for installation of all overhead fibre cable.
- § Dismantling the existing earth wire & hardware wherever overhead FO cables (OPGW) is to be installed on existing lines, and for the preservation and transportation of the dismantled earth wire & hardware to designated stores.
- § Factory and Site acceptance testing of all equipment provided.
- § The SI shall conduct OTDR test on the fibres at the storing areas before installation and end to end test after installation.
- § All documentation and drawings as specified.
- § Supply, install and terminate all Fibre Optic Distribution Panels, fibre patch frames and pig tails.
- § Maintenance and support of the links through final acceptance and through the guarantee period.
- § Due diligence in properly planning and executing the works so as to minimize any damage to crop, forestry or vegetation, internal utilities of any private or government party.
- § The SI shall appoint key personnel for the project such as Project Manager, Site Manager, and Design Engineer. Site Engineers shall be appointed with all installation groups.
- § The SI has to provide storage facility to all materials supplied by the SI for this project till installation of the same. Local Transport, loading and unloading from storage to site is also provided by the SI.

### 1.4. Schedule of Requirement & Delivery

SI. No	Materials required	Quantity
1	Supply of 48 Fibre (DWSM) OPGW optic fibre cable with 5Kms Spare and testing equipment as per Technical specification, at three System Operation Circles at Kannur, Kalamassery & Thiruvananthapuram.	2900.49 Kms
2	Supply of Hardware sets for 48 Fibre (DWSM)OPGW OFC including cable fittings and accessories and for the 5Kms OPGW Spare cable at three System Operation Circles at Kannur, Kalamassery & Thiruvananthapuram.	2900.49 Kms
3	Joint box four way for 48 fibre OPGW cable	800 Nos
4	FODP (96 fibre) indoor type with FC-PC coupling and pig tails (5 mtr each)	100 Nos
5	FODP (48 fibre) indoor type with FC-PC coupling and pig tails (5 mtr each)	160 Nos
6	Non-Metallic armoured underground Optic Fibre approach cable, 48 Fibre, DWSM.	75 Kms
7	PLB HDPE pipe O.D 40 mm including all accessories	75 Kms
8	Survey of route, design and submission of drawing for approval and detailed list of materials required for the work and providing as built drawing after the execution of work.	2900.49 Kms
9	Installation of 48 Fibre (DWSM) OPGW optic fibre cable on 220kV & 110kV towers, fixing of hardware set, cable fittings and accessories and installation of joint boxes and its terminations etc. Pre-installation test (Drum test), Post installation test, splicing and Link test (End to End).	2900.49 Kms
10	Installation of non-metallic armoured underground optical fibre approach cable (UG OFC 48 fibre DWSM) at 220kV & 110kV Substations through existing cable trench by removing concrete slab, installation of HDPE pipe etc. Pre-installation test (Drum test), Post installation test, splicing and Link test (End to end) and placing back concrete slabs as good as in original condition.	75 Nos
11	Installation, testing and commissioning of FODP 96 fibre and termination of OPGW & OF approach cable.	100 Nos
12	Installation, testing and commissioning of FODP 48 fibre and termination of OPGW & OF approach cable.	160 Kms

Table 5: Schedule of Requirement

#### 1.4.1. Test Equipment

List of mandatory test equipment to be provided by the SI

SL No	Test equipment	Quantity (No)	Remarks
1	OTDR (Optical Time Domain Reflectometer) for 1310/1550 nm with laser source and all necessary accessories	11	Anritsu MW9076B1 or equivalent
2	Calibrated Fibre 1km spool	11	
3	Optical Power meter (1310/1550)	11	JDSU OLP55 or equivalent

4	Laser Light source( 1310/1550)	11	EXFO FLS 300-23BL or equivalent
5	Optical Fibre Fusion Splicer incl. Fibre Cleaver with splice kit	3	Sumitomo T-39-SE or equivalent
6	Optical Fibre Talk Set	11	

*Table 6: List of Test Equipment*

## **SECTION III**

### ***Site Survey***



## 1. Survey and Planning

The Bidders are advised to visit sites/routes (at their own expense), prior to the submission of a proposal, and make surveys and assessments as deemed necessary for proposal submission. The successful bidder (SI) is required to visit all sites. The site visits /routes shall include all necessary surveys to allow the SI to perform the design and implementation functions. The SI shall inform their site/routes survey schedule to the Authority well in advance. The site/routes survey schedule shall be finalized in consultation with the Authority. The Authority may be associated with the SI during their site/routes survey activities.

1. SI has to conduct a detailed field survey of all locations specified by the Authority and design / map the Optical Fibre Network on GIS to connect them as part of complete turnkey solution. Design would be prepared on GIS using different layers. Changes proposed during survey, execution and maintenance will also be updated regularly in GIS procured by the SI in the name of the Authority for end to end visibility of network.
2. Bidder must identify any work that be required along the proposed route before cable placement begins.
3. Each section of the route must be properly surveyed by the bidder before cable installation begins. Survey of the aerial route should be carried out pole by pole or tower by tower and assess the site conditions
4. The characteristics of the route need to be investigated by the bidder. Trees or other obstructions, which could hinder placing operation, should be noted. Clearance issues over roadways, driveways, etc. need to be taken into account before cable placement begins
5. The method of cable placement (pulling/lashing etc.) and the tools necessary for placement are dependent upon vehicle accessibility to the cable route which need to be explored.
6. Bidder should verify clearance and separation requirements in all the poles used and also qualify the condition and size of the existing poles to be used, and suggest the need for any additional poles.
7. Verifying the route map provided checking with groups that document the current utilities to prevent SIs from damaging currently installed cables.

### 1.1. As-Built Diagrams

1. SI shall survey to identify the shortest feasible route and submit its As Built Drawings (ABDs) in GIS format (Shape File) along with the Bill of Quantities (BoQ). SI shall be required to submit its hard copies as well.
2. SI shall prepare Base Map having of all geographical features, Route Index Diagram (having all civil features of the cable construction including offset, depth & 3D location of joints) and the ABD having cable details including loop length and long/lat of all network and prominent geographical landmarks.
3. GIS co-ordinates of the entire OFC route at an interval of every 10 metres (including Equipment Site, Jointing / Splicing) shall be captured by SI and will be updated in the GIS tool deployed by the SI for this project. All relevant assets like type of fibre, no. of fibre cores, PoP location, end locations like government and educational institutions, transmission towers, distribution poles and its height, type of pole, available clearance from the ground, location of street box, location of rack, model of equipment installed splice/splitter locations, joints, cable section between two nodes, OLT/ONT locations, etc. to be populated on the GIS map
4. It shall clearly mention under which Package a particular link has been connected.
5. GIS details shall include the following data with attributes:
  - a. GIS coordinates of each transmission tower, line details sub-station, distribution pole, its spacing between poles, towers, type of poles, design of poles, size of poles and pole markings/numbers
  - b. Height of existing cables and fixtures from ground
  - c. Areas where no poles exist and would need new poles
  - d. Obstruction along the path such as trees, hoardings, crossings (road, rail, aerial cables etc.) which needs to be taken care of prior to starting of installation such as tree trimming, moving of hoardings, crossings of existing facility/utility etc.

- e. Manhole locations from where underground installation ends and aerial installation starts and vice-versa
  - f. Route should follow path of transmission line
  - g. Road Network incl. length, width and type (RCC, Kuchha, pakka etc.).
  - h. City Arterial Roads.
  - i. Streets
  - j. Administrative boundaries - District and Sub District Boundary, Town Boundaries.
  - k. Building footprints and names (Hospitals, police stations, offices, educational facilities, Govt. Buildings etc., metro stations, seaports, airports etc.)
  - l. Land-Cover - Green areas, Open Areas, Water bodies
  - m. Address layers (Pin code, Locality, Sub-locality, Bldg number/names)
  - n. For OFC, Overhead or Underground alignment, type of execution (HDD, OT, Aerial etc.), OFC protection used, Depth of OFC, count terminated and spare fibres, loop, make and size of cable deployed, etc.
  - o. Position of Routers, OLT, ONT, Streetbox, Splitter, OFC Joints, Couplers, Manholes, Milestones, Culverts, FTB, power, earthing, ports (all features visible would be picked up) and its Make, Config, fibre loops, loss details, district, PoP name, Parent equipment(like parent OLT)
  - p. Cement/electronic Route Marker (Lat-Long) details & Route Marker Identification.
  - q. Lat Long shall be recorded at 6 decimal accuracy
  - r. Lat/long Readings should invariably be recorded at every turning/bend on the road, road/railway crossings, culverts, diversion etc. Every feature within survey area should be shown in drawing.
6. For all the linear features, geo coordinates shall be recorded at every turning point.
  7. All features in the drawings shall be plotted using UTM coordinates.
  8. All data shall be imported into a central servers/GIS platform procured for the client.
  9. After finalizing the same, the route diagrams / sketch will be prepared on the AUTOCAD map and submitted to the Authority for approval
  10. All the diagrams shall bear the contact information of the surveyor, signatures of the SI and the project manager, start date of survey, completion date etc.
  11. Route maps prepared for the core network of Package A and the line lengths provided for Package B are subject to minor corrections due to local variations. As part of the Route Survey and Network Design Validation activity, the SI should validate and submit the final route maps, network design, BOQ required for actual execution of the work.
  12. SI shall supply and install the materials based on actual work requirements finalized after detailed site survey. The payment will be based on actual quantities of work carried out by the SI.

After the site / route survey, the SI shall submit to the Authority a survey report on each link and site. This report shall include at least the following items:

- a) List of all span lengths and the total link length for cable (OPGW, ADSS, approach cable, UG etc) routes
- b) Suitability for live line installation of OPGW/ADSS cable on the present infrastructure, towers/poles, earth wire, etc.
- c) Tower/Pole wise identification of type(s) and number of fittings & all other accessories required.
- d) Proposed splice locations, types of splice enclosure and cable drum schedules.
- e) Proposed routing of approach cable from the end tower / gantry to the communication room/pre-fabricated structure to be marked on the site layout drawings. The existing cable trenches/ cable raceways in substations proposed to be used shall be identified. In case suitable existing cable trenches are not available, suitable alternatives shall be suggested.
- f) Proposed position of FODP in the existing rooms and buildings of KSEBL and same for pre-fabricated structure.

## Volume- II

---

- g) Identification of facility modifications if required.
- h) Identify all additional items required for integration for each site/location.

**SECTION IV**  
***Technical Specifications***

# 1. Network Component Specification

The SI is encouraged to offer standard products and designs. However, the SI must confirm to the requirements and provide any special equipment necessary to meet the requirements stated herein.

It should be noted that the preliminary information and bill of quantity (BOQ) specified in the Tender Documents are indicative only. The SI shall verify the data during the site surveys & detailed engineering and finalize the BOQ as required for the ultimate design and system performance.

The Bidder's proposal shall address all functional and performance requirements within this specification and shall include sufficient information and supporting documentation in order to determine compliance with this specification without further necessity for enquirers.

An analysis of the functional and performance requirements of this specification and/or site surveys, design, and engineering may lead the SI to conclude that additional items (hardware/software) are required within the intent of this specification that are not specifically mentioned in this specification. The SI shall be responsible for providing to the Authority, all such additional items and such that a viable and fully functional fibre optic link is implemented that meets or exceeds the capacity, and performance requirements specified. Such materials and services shall be considered to be within the scope of the contract. To the extent possible, the Bidders shall identify and include all such additional items (hardware/software) and services in their proposal.

The offered items shall be designed to operate in varying environments. Adequate measures shall be taken to provide protection against rodents, contaminants, pollutants, water & moisture, lightning & short circuit, vibration and electromagnetic interference etc.

## 1.1. Active Components

### 1.1.1 NOC Router

Make Offered:				
Model Offered:				
S. No.	Parameter	Minimum Requirement Description	Compliance Yes/No	Pg. No in Supporting Doc.
1.	Architecture	§ Router should be chassis based & modular architecture for scalability with Redundant Route Processor, Power supply, Switching fabric		
		§ Router should be provided with 1+1 route processor, and 1+1 or 1+N power supply redundancy		
		§ Should have minimum two free full width payload slots for future expansion.		
		§ The router shall support following type of interfaces – 100GE, 10GE, 1GE interfaces.; 10GE G.709 OTN, 10GE WAN PHY		
		§ Router should be CE2.0 or MEF14.0 compliant and should be certified before time of delivery.		
		§ Router shall support MEF for Ethernet based services like PW, VPLS or ATOM.		

**Volume- II**

<b>Make Offered:</b>				
<b>Model Offered:</b>				
<b>S. No.</b>	<b>Parameter</b>	<b>Minimum Requirement Description</b>	<b>Compliance Yes/No</b>	<b>Pg. No in Supporting Doc.</b>
		§ The modular operating system shall run all critical functions like various routing protocol, forwarding plane and management functions in separate memory protected modules. Failure of one module shall not impact operations of rest of the OS. In service bug patching should be available		
		§ The router should support line cards with timing protocol support such as 1588v2 (with boundary clock as well as ordinary clock (master and slave) and sync E		
		§ The 'slot' for any router means a main slot or full slot on the router chassis. Only such a slot shall be counted towards determining the number of free slots. Any sub slot or daughter slot shall not be considered as a slot.		
		§ Router Shall support non-blocking capacity minimum of 4 Tbps.		
		§ The router should have capability of minimum 2 million IPv4 routes considering the traffic and scalability requirements		
		§ The router should have capability of minimum 1 Million IPv6 routes		
		§ The router should support minimum 512k MAC address, minimum 128k Pseudo wires.		
		2.	Performance	§ Router should have Min. 64k multicast routes.
§ The router should support 32 way BGP load balancing and 32 way ECMP				
§ Minimum 32x10G and 20x1G SFP interfaces from day 1				
§ Shall support online insertion and removal (OIR) that is non- disruptive in nature. Online insertion and removal of one line card shall not lead to ANY packet loss for traffic flowing through other line cards for both unicast and multicast traffic.				
§ In case of a line card or Route Processor failure on the router; the multicast and Unicast routing, multicast and Unicast distribution and multicast replication architecture of the router shall ensure no impact & zero packet loss of multicast video, audio & data traffic running on rest of the line cards in the system				
§ If the any of the feature and functionality asked in the RFP is achieved using any service module that should be quoted.				

Make Offered:				
Model Offered:				
S. No.	Parameter	Minimum Requirement Description	Compliance Yes/No	Pg. No in Supporting Doc.
		<p>§ Should have IPv4 Routing, IPv6 Routing, Border Gateway Protocol, Intermediate System-to-Intermediate System [IS-IS], and Open Shortest Path First [OSPF], DHCPv6 and OSPFv3 for IPv6</p>		
		<p>§ Shall support Multicast routing protocols IGMPv1, v2 ,v3, PIM-SM (RFC2362) and PIM-SSM,MSDP,IGMP v2 snooping, MPLS mVPN (Multicast VPN)</p>		
3.	High Bandwidth	<p>§ Shall Support 6PE &amp; 6VPE, MPLS VPN, , MPLS TE (Fast re-route), DiffServ-Aware TE, BGP Prefix Independent Convergence/ BGP LU, Inter-AS VPN, Resource Reservation Protocol (RSVP),RFC 3107 of Carrying Label Information in BGP-4.</p>		
		<p>§ Should support Route Policy (RP), Virtual Router Redundancy Protocol (VRRP/ equivalent), GRE (Generic Routing Encapsulation) Tunneling,</p>		
		<p>§ Shall Support VPLS, HVPLS, Ethernet over MPLS.</p>		
		<p>§ Router shall support MPLS OAM, Ethernet OAM protocols – CFM (IEEE 802.1ag), Link OAM (IEEE 802.3ah) and ITU Y.1731.</p>		
		<p>§ The routers shall support both L2 and L3 services on all interfaces</p>		
		<p>§ Configuration Roll Back to recover the mis-configured router to last good configuration</p>		
4.	QOS	<p>§ Shall support the following:</p>		
		<p>§ Traffic Classification using various parameters like source physical interfaces, source/destination IP subnet, protocol types (IP/TCP/UDP), source/destination ports, IP Precedence, 802.1p, MPLS EXP, DSCP.</p>		
		<p>§ Shall support Strict Priority Queuing or Low Latency Queuing to support real time application like Voice and Video with minimum delay and jitted, Congestion Management: WRED, Priority queuing, Class based weighted fair queuing</p>		
		<p>§ Shall support standards based RSVP for voice &amp; video call admission control.</p>		
		<p>§ Ability to configure hierarchical queues in hardware for IP QoS at the egress to the edge. Minimum 64k egress and 64k ingress hardware queues per line card.</p>		
		<p>§ Platform must support nested hierarchical QoS policies. Router should have 3 level of scheduling for HQOS.</p>		

Make Offered:				
Model Offered:				
S. No.	Parameter	Minimum Requirement Description	Compliance Yes/No	Pg. No in Supporting Doc.
5.	Protocol Support	§ Support Access Control List to filter traffic based on Source & Destination IP Subnet, Source & Destination Port, Protocol Type (IP, UDP, TCP, ICMP etc) and Port Range etc., Time based ACL,AAA using radius or TACACS		
		§ The routers shall provide IETF Netflow-v9/J-Flow/ equivalent feature. This feature shall be available for all interfaces provisioned on the router.		
		§ Should Support MD-5 authentication for RIP, OSPF,IS-IS and BGP.		
		§ Also support URPF,DHCP snooping , control plane policing ,SNMPv3 authentication, SSHv2		
		§ Should have to support Out of band management through Console/ external modem for remote management.		
6.	Others	§ Event and System logging: Event and system history logging functions shall be available. The Router shall generate system alarms on events. Facility to put selective logging of events onto a separate hardware here the analysis of log shall be available.		
		§ SI need to size the port & transceivers requirement as per their solution and if required need to include additional ports for the workability of solution		
		§ The system should not be end of life/end of service product		
7.	Security	§ Support Access Control List to filter traffic based on Source & Destination IP Subnet, Source & Destination Port, Protocol Type (IP, UDP, TCP, ICMP etc) and Port Range etc. Should Support per-user Authentication, Authorization and Accounting through RADIUS or TACACS and SNMPv1/v2/V3		
		§ Black hole filtering: dropping of traffic destined for a specific prefix.		
		§ Ingress and egress packet filtering based on L2-L4 criteria at wire speed. The possibility to log the actions on individual filter rules shall be supported.		
		§ Protection of local services (http, small udp/tcp servers, dhcp, telnet, ssh ...) based on L2-L4 criteria.		
		§ AAA support – Accounting, Authorization and Authentication of users and commands. Support of local authentication, TACACS+ and Radius.		
		§ Authentication of routing protocol updates: RIPv2, IS-IS, OSPF, BGP. SSH support.		



**Volume- II**

<b>Make Offered:</b>				
<b>Model Offered:</b>				
<b>S. No.</b>	<b>Parameter</b>	<b>Minimum Requirement Description</b>	<b>Compliance Yes/No</b>	<b>Pg. No in Supporting Doc.</b>
		§ The router shall support MAC and IP Access Control List (ACL) Security Filtering at line rate without performance degradation.		
		§ Simple password authentication and MD5 authentication shall be supported for RIPv2, IS-IS, OSPF, and BGP routing protocols.		
		§ The router shall support three methods of user authentication:		
		§ User profiles shall be able to be configured to deny or permit access to a hierarchical branch or specific commands. Depending on the authorization requirements, passwords are configured locally or on a RADIUS server. User profiles shall also specify which protocols, such as Telnet, SNMP, FTP, or console access, are allowed by a user to access the system.		
8.	Operating Environmental Requirements	§ 0 C to 40 C		
		§ Storage:EN300019-2-1 class 1.2 or equivalent		
		§ Transport:EN300019-2-2 class 2.3 or equivalent		
		§ In service :EN300019-2-3 class 3.2 or equivalent		
		§ ELECTROMAGNETIC COMPATIBILITY AND SAFETY: • EN 55022, EN 55024 , EN 300 386 or equivalent		

*Table 7: Specifications for NOC Router*

1.1.2.Core Router

Make Offered:				
Model Offered:				
S. No.	Parameter	Minimum Specifications	Compliance Yes/No	Pg. No in Supporting Doc.
1.	Architecture	§ Router should be chassis based & modular architecture for scalability with Redundant Route Processor, Power supply, Switching fabric		
		§ Router should be provided with 1+1 route processor, and 1+1 or 1+N power supply redundancy		
		§ Should have minimum two free full width payload slots for future expansion.		
		§ The router shall support following type of interfaces – 100GE, 10GE, 1GE interfaces.; 10GE G.709 OTN, 10GE WAN PHY		
		§ Router should be CE2.0 or MEF14.0 compliant and should be certified before time of delivery.		
		§ Router shall support MEF for Ethernet based services like PW, VPLS or ATOM.		
		§ The modular operating system shall run all critical functions like various routing protocol, forwarding plane and management functions in separate memory protected modules. Failure of one module shall not impact operations of rest of the OS. In service bug patching should be available		
		§ The router should support line cards with timing protocol support such as 1588v2 (with boundary clock as well as ordinary clock (master and slave) and sync E		
		§ The ‘slot’ for any router means a main slot or full slot on the router chassis. Only such a slot shall be counted towards determining the number of free slots. Any sub slot or daughter slot shall not be considered as a slot.		
		§ Router Shall support non blocking capacity minimum of 2 Tbps.		
		§ The router should have capability of minimum 2 million IPv4 routes considering the traffic and scalability requirements		
		§ The router should have capability of minimum 1 Million IPv6 routes		
§ The router should support minimum 512k MAC address, minimum 128k Pseudo wires.				
2.	Performance	§ Router should have 64k multicast routes.		
		§ The router should support 32 way BGP load balancing and 32 way ECMP		
		§ <b>Core Router where NOC and SDC is getting connected.</b> minimum 2x100 G, 2x40 G, 16x10 and 20x1G SFP interfaces from day 1		

Make Offered:				
Model Offered:				
S. No.	Parameter	Minimum Specifications	Compliance Yes/No	Pg. No in Supporting Doc.
		<p>§ <b>Core Router at other locations</b></p> <p>§ Minimum 4x100 G, 2x40 G, 24x10 G and 20x1G SFP interfaces from day 1</p>		
		<p>§ Shall support online insertion and removal (OIR) that is non- disruptive in nature. Online insertion and removal of one line card shall not lead to ANY packet loss for traffic flowing through other line cards for both unicast and multicast traffic.</p>		
		<p>§ In case of a line card or Route Processor failure on the router; the multicast and Unicast routing, multicast and Unicast distribution and multicast replication architecture of the router shall ensure no impact &amp; zero packet loss of multicast video, audio &amp; data traffic running on rest of the line cards in the system</p>		
		<p>§ If the any of the feature and functionality asked in the RFP is achieved using any service module that should be quoted in 1+1 redundancy.</p>		
		<p>§ Should have IPv4 Routing, IPv6 Routing, Border Gateway Protocol , Intermediate System-to-Intermediate System [IS-IS], and Open Shortest Path First [OSPF]), DHCPv6 and OSPFv3 for IPv6</p>		
		<p>§ Shall support Multicast routing protocols IGMPv1, v2 ,v3, PIM-SM (RFC2362) and PIM-SSM, MSDP, IGMP v2 snooping, MPLS mVPN (Multicast VPN)</p>		
3.	High Bandwidth	<p>§ Shall Support 6PE &amp; 6VPE, MPLS VPN, , MPLS TE (Fast re- route), DiffServ-Aware TE, BGP Prefix Independent Convergence/ BGP LU, Inter-AS VPN, Resource Reservation Protocol (RSVP), RFC 3107 of Carrying Label Information in BGP-4.</p>		
		<p>§ Should support Route Policy (RP), Virtual Router Redundancy Protocol (VRRP/ equivalent), GRE (Generic Routing Encapsulation) Tunneling,</p>		
		<p>§ Shall Support VPLS, HVPLS, Ethernet over MPLS.</p>		
		<p>§ Router shall support MPLS OAM, Ethernet OAM protocols – CFM (IEEE 802.1ag), Link OAM (IEEE 802.3ah) and ITU Y.1731.</p>		
		<p>§ The routers shall support both L2 and L3 services on all interfaces</p>		
		<p>§ Configuration Roll Back to recover the mis-configured router to last good configuration</p>		
4.	QOS	<p>§ Shall support the following:</p>		

**Volume- II**

<b>Make Offered:</b>				
<b>Model Offered:</b>				
<b>S. No.</b>	<b>Parameter</b>	<b>Minimum Specifications</b>	<b>Compliance Yes/No</b>	<b>Pg. No in Supporting Doc.</b>
		§ Traffic Classification using various parameters like source physical interfaces, source/destination IP subnet, protocol types (IP/TCP/UDP), source/destination ports, IP Precedence, 802.1p, MPLS EXP, DSCP.		
		§ Shall support Strict Priority Queuing or Low Latency Queuing to support real time application like Voice and Video with minimum delay and jitter, Congestion Management: WRED, Priority queuing, Class based weighted fair queuing		
		§ Shall support standards based RSVP for voice & video call admission control		
		§ Ability to configure hierarchical queues in hardware for IP QoS at the egress to the edge. Minimum 64k egress and 64k ingress hardware queues per line card.		
		§ Platform must support nested hierarchical QOS policies .Router should have 4 level of scheduling for HQOS.		
5.	Protocol Support	§ Support Access Control List to filter traffic based on Source & Destination IP Subnet, Source & Destination Port, Protocol Type (IP, UDP, TCP, ICMP etc) and Port Range etc., Time based		
		§ ACL,AAA using radius or TACACS		
		§ The routers shall provide IETF Netflow-v9/J-Flow/equivalent feature. This feature shall be available for all interfaces provisioned on the router.		
		§ Should Support MD-5 authentication for RIP, OSPF,IS-IS and BGP.		
		§ Also support URPF,DHCP snooping , control plane policing ,SNMPv3 authentication, SSHv2		
		§ Should have to support Out of band management through Console / external modem for remote management.		
6.	Other Support	§ Event and System logging: Event and system history logging functions shall be available. The Router shall generate system alarms on events. Facility to put selective logging of events onto a separate hardware here the analysis of log shall be available.		
		§ SI need to size the port & transceivers requirement as per their solution and if required need to include additional ports for the workability of solution		
		§ The system should not be end of life/end of service product not within Next Five Years		

Make Offered:				
Model Offered:				
S. No.	Parameter	Minimum Specifications	Compliance Yes/No	Pg. No in Supporting Doc.
7.	Security	§ Support Access Control List to filter traffic based on Source & Destination IP Subnet, Source & Destination Port, Protocol Type (IP, UDP, TCP, ICMP etc) and Port Range etc. Should Support per-user Authentication, Authorization and Accounting through RADIUS or TACACS and SNMPv1/v2/V3		
		§ Black hole filtering: dropping of traffic destined for a specific prefix.		
		§ Ingress and egress packet filtering based on L2-L4 criteria at wire speed. The possibility to log the actions on individual filter rules shall be supported.		
		§ Protection of local services (http, small udp/tcp servers, dhcp, telnet, ssh ...) based on L2-L4 criteria.		
		§ AAA support – Accounting, Authorization and Authentication of users and commands. Support of local authentication, TACACS+ and Radius.		
		§ Authentication of routing protocol updates: RIPv2, IS-IS, OSPF, BGP.		
		§ SSH support.		
		§ The router shall support MAC and IP Access Control List (ACL) Security Filtering at line rate without performance degradation.		
		§ Simple password authentication and MD5 authentication shall be supported for RIPv2, IS-IS, OSPF, and BGP routing protocols.		
		§ The router shall support three methods of user authentication:		
	§ User profiles shall be able to be configured to deny or permit access to a hierarchical branch or specific commands. Depending on the authorization requirements, passwords are configured locally or on a RADIUS server. User profiles shall also specify which protocols, such as Telnet, SNMP, FTP, or console access, are allowed by a user to access the system.			
8.	Operating Environmental Requirements	§ 0 C to 40 C		
		§ Storage:EN300019-2-1 class 1.2 or equivalent		
		§ Transport:EN300019-2-2 class 2.3 or equivalent		
		§ In service :EN300019-2-3 class 3.2 or equivalent		
		§ ELECTROMAGNETIC COMPATIBILITY AND SAFETY: • EN 55022, EN 55024 , EN 300386 or equivalent		

Table 8: Specifications for Core Router

**1.1.3 Aggregation Router**

Make Offered:				
Model Offered:				
S. No.	Parameter	Minimum Specifications	Compliance Yes/No	Pg. No in Supporting Doc.
1.	Architecture	§ Router should have redundant controller cards and should support stateful switch over, non-stop forwarding, Non-stop routing and Graceful restart.		
		§ Router should be CE2.0 or MEF14.0 compliant and should be certified before time of delivery.		
		§ Router shall support MEF for Ethernet based services like PW, VPLS or ATOM.		
		§ In case of failure of any single route processor none of the line card traffic should be impacted		
		§ Router shall support sync any configurations from previous modules to new modules with hot-swap event occurred		
		§ The Chassis should have minimum one free slot for future expansion.		
		§ The router shall support following type of interfaces – 100G, 10G, 1GE and 10G WANPHY.		
2.	Performance	§ Router shall support non-blocking capacity of Minimum 400 Gbps full duplex		
		§ Router shall support Minimum 128,000 MAC addresses		
		§ Router shall support minimum 300K IPv4 and 150 K IPv6 routes		
		§ Router shall support aggregation of links. Minimum 6 link should be supported as part of single aggregation		
		§ Minimum 2x40 G, 8x10 G and 16x1G SFP interfaces from day 1		
		§ Router shall support IPSLA or equivalent and Y.1731 for performance monitoring.		
3.	High Availability	§ Router should support Redundant Power Supply and should also support On line insertion and removal of same.		
		§ Fan tray should be hot-swappable, and should be a Field Replaceable Unit (FRU). The node can run indefinitely with a single fan failure. Shall Support hot-swappable for all modules. And secure normal operations when hot-swap event occurred		
		§ Router shall support MPLS-TE with FRR for sub 50 msec protection.		
		§ Router must support Traffic Engineering for node and link protection.		
4.	Protocol Support	§ Router shall support IPV4 and IPV6,IGMP V2/V3,MLD,IGMP and PIM,6PE and 6VPE mode for IPV6 transport over IPV4, ECMP,LDP, BGP Prefix independent control/ BGP LU (EDGE and Core) for IPV4 and IPV6,BGP,IS-IS,OSPFv2and V3,RSVP,VRRP,Loop free alternate FRR (IPFRR) and Traffic Engineering.		

Make Offered:				
Model Offered:				
S. No.	Parameter	Minimum Specifications	Compliance Yes/No	Pg. No in Supporting Doc.
		§ Router should support high availability for all BFD, BGP, OSPF and IS-IS and no packet loss during controller switch over.		
		§ Router should support RFC 3107 of Carrying Label Information in BGP-4		
		§ The Router should support Point to Point and Point to Multipoint LSP for Unicast and Multicast traffic.		
		§ Router shall support layer3 and layer2 MPLS VPN.		
5.	QoS Features	§ Router shall support 3 level HQOS on all kind of interface in both ingress and egress direction. Similar QoS shall be supported for all type of interface including Bundled interfaces.		
		§ Shall support Ingress classification, marking and policing on physical interfaces and logical interfaces using source/destination IP subnet, protocol types (IP/TCP/UDP), source/destination ports, IP Precedence, MPLS EXP, DSCP,802.1p		
		§ Shall support Strict Priority Queuing or Low Latency Queuing to support real time application like Voice and Video with minimum delay and jitter.		
		§ Congestion Management: WRED, Priority queuing, Class based weighted fair queuing		
6.	Security & Management	§ Support Access Control List to filter traffic based on Source & Destination IP Subnet, Source & Destination Port, Protocol Type (IP, UDP, TCP, ICMP etc) and Port Range etc. Should Support per-user Authentication, Authorization and Accounting through RADIUS or TACACS and SNMPv1/v2/V3		
7.	Operating Environmental Requirements	§ 0°C to 40°C operating temperature		

Table 9: Specifications for Aggregation Router

### 1.1.4 Pre-Aggregation Router

Make Offered:				
Model Offered:				
S. No.	Parameter	Minimum Specifications	Compliance Yes/No	Pg. No in Supporting Doc.
1.	Architecture	§ Router should have redundant controller cards and should support stateful switch over, non-stop forwarding, Non-stop routing and Graceful restart.		
		§ Router should have redundant control and data plane.		
		§ Router should be CE2.0 or MEF14.0 compliant and should be certified before time of delivery.		

**Volume- II**

<b>Make Offered:</b>				
<b>Model Offered:</b>				
<b>S. No.</b>	<b>Parameter</b>	<b>Minimum Specifications</b>	<b>Compliance Yes/No</b>	<b>Pg. No in Supporting Doc.</b>
		§ Router shall support MEF for Ethernet based services like PW, VPLS or ATOM.		
		§ In case of failure of any single route processor none of the line card traffic should be impacted		
		§ Router shall support sync any configurations from previous modules to new modules with hot-swap event occurred		
		§ The Chassis should have minimum one free slot for future expansion. All the slots should support all the line cards.		
		§ The router shall support following type of interfaces – 10GE, 1GE interfaces; 10GE WAN PHY and 10G.		
2.	Performance	§ Router shall support non-blocking capacity of Minimum 200 Gbps full duplex.		
		§ Router shall support Minimum 64, 000 MAC addresses		
		§ Router shall support Minimum 128,000 IPv4 routes and 64,000 IPv6 routes		
		§ Router shall support 6000 queues and 100 MPLS VPNs		
		§ Router shall support aggregation of links. Minimum 8 link should be supported as part of single aggregation		
		§ Minimum 6x10G and 16x1G SFP interfaces from day 1		
3.	High Availability	§ Router should support Redundant Power Supply and should also support On line insertion and removal of same.		
		§ Fan tray should be hot-swappable, and should be a Field Replaceable Unit (FRU).		
		§ Router shall support MPLS-TE with FRR for sub 50 msec protection.		
		§ Router must support Traffic Engineering for node and link protection.		
4.	Protocol Support	§ Router shall support IPV4 and IPV6,IGMP V2/V3,MLD,IGMP and PIM,6PE and 6VPE mode for IPV6 transport over IPV4, ECMP,LDP,BGP Prefix independent control/ BGP LU (EDGE and Core) for IPV4 and IPV6,BGP,IS-IS,OSPFv2and V3,RSVP,RRRP,Loop free alternate FRR (IPFRR) and Traffic Engineering.		
		§ Router should support high availability for all BFD,BGP ,OSPF and IS-IS and no packet loss during controller switch over.		
		§ Router should support RFC 3107 of Carrying Label Information in BGP-4		
		§ The Router should support Point to Point and Point to Multipoint LSP for Unicast and Multicast traffic.		



## Volume- II

Make Offered:				
Model Offered:				
S. No.	Parameter	Minimum Specifications	Compliance Yes/No	Pg. No in Supporting Doc.
		§ Router shall support layer3 and layer2 MPLS VPN.		
5.	QoS Features	§ Router shall support 3 level HQOS on all kind of interface in both ingress and egress direction. Similar QoS shall be supported for all type of interface including Bundled interfaces.		
		§ Shall support Ingress classification, marking and policing on physical interfaces and logical interfaces using source/destination IP subnet, protocol types (IP/TCP/UDP), source/destination ports, IP Precedence, MPLS EXP, DSCP,802.1p		
		§ Shall support Strict Priority Queuing or Low Latency Queuing to support real time application like Voice and Video with minimum delay and jitter.		
		§ Congestion Management: WRED, Priority queuing, Class based weighted fair queuing		
6.	Security & Management	§ Support Access Control List to filter traffic based on Source & Destination IP Subnet, Source & Destination Port, Protocol Type (IP, UDP, TCP, ICMP etc) and Port Range etc. Should Support per-user Authentication, Authorization and Accounting through RADIUS or TACACS and SNMPv1/v2/V3		
7.	Operating Environmental Requirements	§ 0°C to 40°C operating temperature and 5 to 90%, non-condensing		

Table 10: Specifications for Pre-Aggregation Router

### 1.1.5 Spur Router

Make Offered:				
Model Offered:				
S. No.	Minimum Specification	Compliance Yes/No	Pg. No in Supporting Doc.	
1.	Router shall support non-blocking capacity of minimum 60 Gbps full duplex			
2.	Router should be CE2.0 or MEF14.0 compliant and should be certified before time of delivery.			
3.	Router should support the following environmental condition :			
	Temperature: 0 to 65 degrees			
	Relative humidity: 5 to 95%			
4.	A single point failure on the equipment shall not result in network or network management system downtime			

Make Offered:			
Model Offered:			
S. No.	Minimum Specification	Compliance Yes/No	Pg. No in Supporting Doc.
5.	Router should support Quality of service for marking, Prioritising and assuring bandwidth Guarantee. Classification can be done based on DSCP, Priority, IP address and 802.1p.		
6.	Router should also support RSVP for end to end bandwidth guarantee.		
7.	Router should support modular QoS with Multilevel Priority Queue along with weighted fair queuing.		
8.	Router should also support Policy for control plane protection		
9.	Router shall support Minimum 12,000 IPv4 routes and 6,000 IPv6 routes		
10.	The router should have 4Gb DRAM and 2GB flash		
11.	The Router should support multilevel priority scheduling for voice and video applications with minimal jitter, latency and packet loss.		
12.	The Router shall support fault-tolerant connections to other network or shared media segment to protect against a primary link failure. If the primary link fails, the backup path shall be automatically activated to maintain network connectivity and throughput.		
13.	The Router should support the following protocols: BGP,MPBGP,OSPF ,RFC 3107 ,OSPFv2 and v3,Loop free alternate ,IP FRR,6PE,6VPE,VPLS/HVPLS,Layer2 VPN, uRPF, PIMSM and PIM SSM.		
14.	The router should support fast convergence protocols like G.8032, IPFRR,MPLS FRR,BGP prefix independent convergence/ BGP LU, VRRP or equivalent and BFD for Routing protocols.		
15.	The Router should support Point to Point and Point to Multipoint LSP for Unicast and Multicast traffic.		
16.	The proposed router shall support Layer 2 and Layer 3 multicast VPN.		
17.	It shall support Ethernet Ring protection based on ITU-T G.8032 v2		
18.	It shall support the following protocols:-		
	ξ The Router shall support both IPv4 and IPv6		
	ξ The router should support Internet Group Management Protocol versions 2 and 3 (IGMPv2 and v3) ,IP/MPLS,IP FRR,BGP PIC/ BGP LU,MPLS LDP,MPLS TE		
19.	The Router should support layer 2 and layer 3 MPLS VPN.		

Make Offered:			
Model Offered:			
S. No.	Minimum Specification	Compliance Yes/No	Pg. No in Supporting Doc.
20.	Shall support Frame sizes from 64 bytes to 1600 and to 9216 bytes on all ports		
21.	Minimum 2x10 G, 12x 1G Interfaces from Day1		
22.	Router should support Eight No of hardware queues are required for per port for flow treatment of traffic, Policy Based QOS, WRED, WFQ, HQOS, Ethernet OAM and Y.1731 performance management		
23.	The router should support Zero touch provisioning for ease of management		
24.	The Router must support the following security features:-		
	Security through ACL filters for layers 2 and layer 3 traffic, MAC address limits and storm control for broadcast/ multicast and unknown unicast, Authentication, authorization, and accounting (AAA) with TACACS+ and RADIUS,URPF		

Table 11: Specifications for Spur Router

### 1.1.6 Internet Router

Make Offered:				
Model Offered:				
S. No.	Parameter	Minimum Specifications	Compliance Yes/No	Pg. No in Supporting Doc.
1.	Architecture	§ Router should have redundant controller cards and should support stateful switch over, non-stop forwarding, Non-stop routing and Graceful restart.		
		§ Router should be CE2.0 or MEF14.0 compliant and should be certified before time of delivery.		
		§ Router shall support MEF for Ethernet based services like PW, VPLS or ATOM.		
		§ In case of failure of any single route processor none of the line card traffic should be impacted		
		§ Router shall support sync any configurations from previous modules to new modules with hot-swap event occurred		
		§ The Chassis should have minimum one free slot for future expansion.		
		§ The router shall support following type of interfaces – 100G, 10G, 1GE and 10G WANPHY.		
2.	Performance	§ Router shall support non-blocking capacity of Minimum 400 Gbps full duplex		
		§ Router shall support Minimum 128,000 MAC addresses		

**Volume- II**

<b>Make Offered:</b>				
<b>Model Offered:</b>				
<b>S. No.</b>	<b>Parameter</b>	<b>Minimum Specifications</b>	<b>Compliance Yes/No</b>	<b>Pg. No in Supporting Doc.</b>
		§ Router shall support minimum 500K IPv4 and 250 K IPv6 routes		
		§ Router shall support aggregation of links. Minimum 6 link should be supported as part of single aggregation		
		§ Minimum 16x10 G SFP interfaces from day 1		
		§ Router shall support IPSLA or equivalent and Y.1731 for performance monitoring.		
3.	High Availability	§ Router should support Redundant Power Supply and should also support On line insertion and removal of same.		
		§ Fan tray should be hot-swappable, and should be a Field Replaceable Unit (FRU). The node can run indefinitely with a single fan failure. Shall Support hot-swappable for all modules. And secure normal operations when hot-swap event occurred		
		§ Router shall support MPLS-TE with FRR for sub 50 msec protection.		
		§ Router must support Traffic Engineering for node and link protection.		
4.	Protocol Support	§ Router shall support IPV4 and IPV6,IGMP V2/V3,MLD,IGMP and PIM,6PE and 6VPE mode for IPV6 transport over IPV4, ECMP,LDP, BGP Prefix independent control/ BGP LU (EDGE and Core) for IPV4 and IPV6,BGP,IS-IS,OSPFv2and V3,RSVP,VRRP,Loop free alternate FRR (IPFRR) and Traffic Engineering.		
		§ Router should support high availability for all BFD, BGP ,OSPF and IS-IS and no packet loss during controller switch over.		
		§ Router should support RFC 3107 of Carrying Label Information in BGP-4		
		§ The Router should support Point to Point and Point to Multipoint LSP for Unicast and Multicast traffic.		
5.	QoS Features	§ Router shall support 3 level HQOS with minimum 64k hardware queues on all kind of interface in both ingress and egress direction. Similar QoS shall be supported for all type of interface including Bundled interfaces.		
		§ Shall support Ingress classification, marking and policing on physical interfaces and logical interfaces using source/destination IP subnet, protocol types (IP/TCP/UDP), source/destination ports, IP Precedence, MPLS EXP, DSCP,802.1p		
		§ Shall support Strict Priority Queuing or Low Latency Queuing to support real time application like Voice and Video with minimum delay and jitter.		
		§ Congestion Management: WRED, Priority queuing, Class based weighted fair queuing		

Make Offered:				
Model Offered:				
S. No.	Parameter	Minimum Specifications	Compliance Yes/No	Pg. No in Supporting Doc.
6.	Security & Management	ξ Support Access Control List to filter traffic based on Source & Destination IP Subnet, Source & Destination Port, Protocol Type (IP, UDP, TCP, ICMP etc) and Port Range etc. Should Support per-user Authentication, Authorization and Accounting through RADIUS or TACACS and SNMPv1/v2/V3		
7.	Operating Environmental Requirements	ξ 0°C to 40°C operating temperature		
8.	Certifications	ξ The proposed router or family of router should be NDPP/ EAL certified by common Criteria body before the time of delivery..		

Table 12: Specifications for Internet Router

### 1.1.7 DWDM

#### 1.1.7. Establishment of Core DWDM network

- 14 Tier-1 PoPs shall have provisioned DWDM equipment which co-exists with IP/MPLS routers.
- Inter-District 100 G DWDM Network to serve aggregated capacity as well as come over distance limitations, expandable to multiple 100 Gbps.
- The DWDM Transmission System shall be installed over OPGW/ADSS Physical Fibre. The Optical Transmission Backbone for KFON will be rolled out as a Highly Resilient DWDM Network based on a hierarchical network comprising of State and District Networks with specific reference to Network Capacity, Network Re-convergence during Faults, Scalability, Traffic Engineered Fail-over Response and Network Protection Plan.
- The network architecture shall be based on ring topology comprising of highly robust District networks based on DWDM optics for multi rate client interfaces with no single point of failure. The architecture should enable capacity growth, bandwidth growth and flexibility with wavelength management, traffic engineering and service provisioning.
- The Overall NETWORK architecture shall be designed such that the convergence time for the Network shall be less than 50 ms

#### 1.1.7. Design Criteria

The fibre optic link budget calculations shall be calculated based upon the following criteria:

- Fibre Attenuation:** Standard fibre attenuation of 0.22 dB/km shall be taken.
- Connector Losses:** Losses due to connectors shall be considered to be minimum 0.5 dB per connector. 4 dB Span fibre margin should be considered for each span of 80 km.

#### Capacity:

- The DWDM based transmission network should support minimum 80 Lambdas of 100G. The requisite hardware in terms of EDFA amplifiers etc. for all route directions shall be supplied as part of the DWDM system.

#### Optical Line Amplifier Site:

## Volume- II

---

1. Network will require some sites to be equipped with Optical Line Amplifier with requisite gain and launch power to meet the optical transmission requirements
2. These amplifier sites shall be supplied with all requisite components, accessories for a fully functional system.
3. Both the transmitter booster amplifier and the receive preamplifier shall be an integral part of DWDM systems whereas the inline amplifier shall be located somewhere along the transmission line away from the terminal stations.

### Wavelength Planning:

1. Wavelength planning for all types of systems will be done in accordance with ITU-T DWDM Grid.

### Protection:

1. **Fibre Path Protection:** Transmission layer shall be able to support redundant fibre path protection. The total time taken for fault detection and switching from active to standby fibre link should be less than 50ms without any interruption of live traffic.
2. **Equipment Protection:** The offered DWDM based optical transmission systems should support redundant controller configuration. Based on site requirement the same will be provisioned. In case of failure of the active controller, the standby controller should take over automatically with no disruption in the services/transmission connectivity.
3. **Power Supply Protection:** There shall be provision for feeding DC supply from two sources. Failure of one of the two supplies shall not cause shut down of the system. Under these conditions there shall not be any damage to the software, hardware and configuration data.

### Network (NW) Planning Tool:

1. Network planning tool shall facilitate to simulate networks. NW Planning Tool shall emulate the behaviour of DWDM networks.
2. It should support multi degree reconfigurable optical add/drop multiplexer technology
3. Should be able to manage all the associated liner effects (Optical power budget, chromatic dispersion effects, non – linear effects include cross-phase modulation, self-phase modulation, etc.
4. The purpose of the Planning tool is to carry out green field network planning, maximize the quality of service provided to customer and to optimize the network resources. The NW Planning Tool shall help purchaser to plan, develop, manage and upgrade their transport network.
5. Capacity Planning: Having the current network topology (and the current network occupation) as input, it should be possible to do the capacity planning analysis. The network inventory shall allow generation of a list of all the resources available in the network.

### System Architecture:

The system shall support a Modular Architecture, in order to allow scaling the equipment size in accordance with the requirement of growth of network. The modular architecture should facilitate identification of faults and replacement of faulty cards/modules in a hitless manner.

1. **Robustness:** The system should provide carrier grade robustness (sub 50ms change over without data, voice or video traffic deterioration) and redundancy with no single point of failure.
2. **Scalability:** The core network must be able to grow and expand using open-ended software/ hardware. The network must be scalable from NMS perspective and should cater for future expansion.
3. **Flexibility:** The offered transmission system should allow flexibility of configuration, addition, alteration or removal of cards/components without affecting the functionality of the system.
4. **Continuous Operation:** The network should be operational on 24x7x365 days basis. It should be possible to add lambdas or upgrade the channels by addition of cards or other necessary hardware in a hitless operation.
5. **Flexible Management and Control:** The system should provide flexible management and control and should be designed to simplify network planning, engineering and operation, enable simplified testing and improve system reliability
6. **Safety:** The system must provide the necessary features to guarantee the safety of personnel operating the equipment. The equipment should be compliant with the ETSI/ NEBS standards.

## Volume- II

7. **EMS:**The Management System shall be able to discover the NEs and the corresponding connections between the NEs, and create the sub-networks and the different types of NEs (e.g., ROADMs, cross connect nodes and ILAs) within a sub-network shall also be identified and distinguished.
8. The proposed DWDM solution should support OTN functionality without changing the entire DWDM system.

### Minimum required interfaces:

#### DWDM at Ring 1:

- a. 10 x100 G for the Trunk/ Line Connectivity (for both the direction)
- b. 2x100G at the client side
- c. 2 cards of 10x10G at the client side

#### DWDM at Ring 2:

### Minimum required interfaces:

- a. 6 x100 G for the Trunk/ Line Connectivity (for both the direction)
- b. 2x100G at the client side
- c. 2 cards of 10x10G at the client side

#### DWDM where NOC and SDC getting terminated:

### Minimum required interfaces:

- a. 10 x100 G for the Trunk/ Line Connectivity (for both the direction)
- b. 4x100G at the client side
- c. 2 cards of 10x10G at the client side

### 1.1.7. Hardware Specification

The minimum hardware specification for all equipment to be utilized for establishing of Core DWDM network is specified as under:

Make Offered:				
Model Offered:				
S. No.	Parameter	Minimum Specifications	Compliance Yes/No	Pg. No in Supporting Doc.
1.	Multi-Protocol Support	The client interfaces must support the following protocols:		
		ξ 10G LAN/WAN PHY		
2.	10G protocol support	Standard G.709 (10.70 Gbps)		
		G.709 over clocked to transport 10GE as defined by ITU-T G		
3.	Form factor	The Client ports must be SFP/SFP+/QSFP based and trunks		
		ports should support XFP/MSA based		
4.	Reach	For grey SFP , SR , LR , ER and ZR reaches must be supported		
5.	Low Rate/High Rate	It Should support 10G, 40G and 100G wavelengths in the client side card		
6.	Transparency	Client traffic should be transported transparently		

**Volume- II**

<b>Make Offered:</b>				
<b>Model Offered:</b>				
<b>S. No.</b>	<b>Parameter</b>	<b>Minimum Specifications</b>	<b>Compliance Yes/No</b>	<b>Pg. No in Supporting Doc.</b>
7.	10G laser safety	Shall support UL Certification policy guideline IEC/UL 60950-1 Application guideline		
8.	Protection	The card must support Y-cable and splitter protection for all services.		
9.	Performance Monitoring	Calculation and accumulation of the Performance Monitoring data are supported in 15-minute and 24-hour intervals as per G.7710.		
10.	Performance Monitoring	GE should be compatible with RMON standard		
11.	Operating temperature	0 C to 40 C		
12.	Software Upgrade	The addition of the software license should not disrupt existing traffic.		
13.	Wavelengths Support	It must be possible to support minimum 80 channels on the 100G in the trunk.		
14.	ETSI	All cards shall be compliant with ETSI standards		

*Table 13: Specifications for DWDM*

**1.1.7.ROADM for DWDM**

<b>Make Offered:</b>				
<b>Model Offered:</b>				
<b>S. No.</b>	<b>Parameter</b>	<b>Minimum Specifications</b>	<b>Compliance Yes/No</b>	<b>Pg. No in Supporting Doc.</b>
1.	General	ROADM should be able to handle at least 80 different wavelengths of C- Band in each direction		
		The ROADM shall offer the possibility to achieve the interconnection of its max. Stated capacity and make re-routing on a per wavelength basis.		
		The ROADM shall create a fully non-blocking multi-directional optical switching node with no limitations to the number of channels added or dropped or passed through from any direction. Restrictions on dropping if any should be clearly indicated.		
		The ROADM should support directional coloured ROADM with 50 GHz spacing per ITUT.		
		Each side of an ROADM node is to be split logically and physically, ensuring that there are no single points of failure that would cause add/drop traffic to be lost on multiple degrees.		



Make Offered:				
Model Offered:				
S. No.	Parameter	Minimum Specifications	Compliance Yes/No	Pg. No in Supporting Doc.
		The ROADMs must have a OCM module for power monitoring		
		The ROADMs must have per channel VOAs (variable optical attenuator) to equalize all the DWDM channels - added locally and expressed		
		Vendor must provide the insertion loss for ROADMs on all paths		
		The vendor must use optimised solutions for ROADMs - single module ROADMs that have WSS. Pre-amplifier, line amplifier and OSC add drop integrated to a single card		
		ROADM must be fully remotely configurable from the EMS/NMS		
		Add/Drop channels shall be remotely selected from all the 80 wavelengths constituting the DWDM aggregate, in a flexible way.		
		Functional View: The network management interface should provide a node level view of the internal patch cord connections and the signal flow in the node for all directions		
		Functional View: The network management interface should provide a network level view of the internal patch cord connections of all the nodes and the end to end signal flow in the network		
		In the above network level view, it should be possible to view at all points in the network for the following:		
		9 Power values in dBm		
		9 Span loss values in Db		
		9 Patch cord verification for all internal connections based on the power values		
		9 Individual circuit paths and associated parameters		
2.	Automatic Power Correction	A mechanism should be available to monitor power at a network level and correct changes in power due to channel addition / deletion and fibre degradation		
3.	Automatic Node Set-up	The planning output file should include pre-provisioning of equipment, side information, per channel output power required for ROADM VOAs & amplifiers, Loss of Power threshold at receive ports.		
4.	Network Alarm Correlation	The vendor solution must be compliant with ITU - G.798		
		A mechanism should exist for all the alarms in the network to be correlated in case of failure of OMS/OTS link and only the source alarm must be raised as critical while all other alarms are suppressed		

**Volume- II**

Make Offered:				
Model Offered:				
S. No.	Parameter	Minimum Specifications	Compliance Yes/No	Pg. No in Supporting Doc.
5.	ETSI	All cards should be compliant with ETSI quality standard		

*Table 14: Specifications for ROADM for DWDM*

**1.1.7. DWDM Amplifier**

Make Offered:				
Model Offered:				
S No.	Parameter	Minimum Specifications	Compliance Yes/No	Pg. No in Supporting Doc.
1.	General	The amplifiers should have flexibility to be Software-configured as pre-amplifier, post-amplifier		
		Required number of additional amplifier wherever required based on the distance and loss to be provided by the bidder.		
		There shall be active control of express traffic to adapt instantly the amplifier-pair to wavelength count never being affected by any degradation arising out from rapid reconfigurations. Sudden addition/removal of channels at intermediate site must not affect whole transmission of DWDM signals.		
		The optical amplifiers shall respond automatically to changes in the number of channels without the need for manual intervention or realignment.		
		The adaptation response for restoration after ILA fault, fibre-plant restoration or change in power levels etc., shall be immediate. The In Post Amplifier and Pre Amplifier shall support optical spectrum monitoring, which will not only apply the correction to channels to keep the spectrum flat, but also shall be used for the monitoring of optical monitoring as per ITU-T G.697.		
		The optical amplifiers must implement the following mechanisms to maintain error free system operation under dynamic conditions:		
		a. Fast gain control loop: to protect against short term transient conditions such sudden loss of channels.		
		b. Slow output power control loop: to protect against long term conditions such fibre aging.		
2.		The amplifier must have an embedded gain-flattening filter		

**Volume- II**

Make Offered:				
Model Offered:				
S No.	Parameter	Minimum Specifications	Compliance Yes/No	Pg. No in Supporting Doc.
	Coherent amplifier features	The amplifiers should support two modes of operation - constant gain and constant power - while also providing Amplified Spontaneous Emission (ASE) compensation in either modes		
		The amplifier should provide fast-transient suppression to respond quickly to network changes without adding impairments and degradation.		
		The amplifier should have extensive optical monitoring with photo diodes, to provide nodal- and network-based automatic power-level management.		
3.	Coherent amplifier Specifications	The Bidder to propose the amplifier based on the network design including distance and fibre parameter mentioned in the RFP.		
4.	Optical Safety	Amplifiers should comply to the following :EN or IEC-60825-2 Third edition (2004-06); EN or IEC 60825-1 Consol. Ed. 1.2 - incl. am1+am2 (2001-08); 21CFR1040 (2004/04) (Accession Letter and CDRH Report); IEC-60825-2 Third edition (2004-06); ITU-T G.664 (2006)		
5.	Safety	Amplifiers should comply to the following :UL/CSA 60950 -1 First Edition (2003); GR-1089-CORE, Issue 4 (Type 2 and Type 4 equipment); UL/CSA 60950 -1 First Edition (2003);IEC 60950-1 (2001/10)/Amendment 11:2004 to EN 60950-1:2001, 1st Edition (with all country deviations)		

*Table 15: Specifications for DWDM Amplifier*

**1.1.7. DWDM Trunk**

Make Offered:				
Model Offered:				
S. No.	Parameter	Minimum Specifications	Compliance Yes/No	Pg. No in Supporting Doc.
1.	100G performance	100G DWDM line card must use a coherent receiver with a receive and transmit DSP. The receive DSP performs compensation for Chromatic Dispersion (CD), Polarization impairments, performs carrier phase estimation and FEC decoding. The transmit DSP performs CD pre-compensation, Nyquist shaping and FEC coding.		
		The modulation scheme for 100G DWDM must be CP-DQPSK (Coherent Polarized Differential Quadrature Phase Shift Keying) also called PM-QPSK.		

**Volume- II**

<b>Make Offered:</b>				
<b>Model Offered:</b>				
<b>S. No.</b>	<b>Parameter</b>	<b>Minimum Specifications</b>	<b>Compliance Yes/No</b>	<b>Pg. No in Supporting Doc.</b>
		The Coherent DWDM transmitter and receiver must support atleast 80 channels in the C-Band from 1528.77 and 1566.72nm (C-Band – 50 GHz)		
		The Coherent DWDM Transponder must have a gridless laser i.e. tunable in increments of +/- 0.1 Ghz.		
		The maximum reach of the 100G CP-DQPSK DWDM signal for G.652 fibre with standard specifications of loss coefficient, CD, PMD should be minimum 1000 km		
		The Minimum Chromatic dispersion tolerance for 100G CP-QPSK DWDM signal should be minimum 18,000 ps/nm or better		
2.	100G standards compliance	Support for G.709, G.975, G.691, GR-253-Core - Issue04; G8021		
3.	100G laser safety	Support for Automatic Laser Shutdown and restart based on ITU-T G.664 (06/99)		
		Support for LC duplex connectors with shutters		
		Support for UL 60950-1 - Edition 2, March 2007 6		
		Vendor must support 100G DWDM interface protection with redundant interfaces on separate DWDM cards		
		Support for G.709 Generic Communication Channel GCC of the 100G DWDM interface		
		The 100-Gbps DWDM Trunk provides support for both Transparent and Non-Transparent signal transport Performance Monitoring		
		Calculation and accumulation of the Performance Monitoring data in 15-minute to 24-hour intervals as per G.7710. 10		

*Table 16: Specifications for DWDM Trunk*

**1.1.7. OTN**

<b>Make Offered:</b>				
<b>Model Offered:</b>				
<b>S. No.</b>	<b>Parameter</b>	<b>Minimum Specifications</b>	<b>Compliance Yes/No</b>	<b>Pg. No in Supporting Doc.</b>
1.	OTN switching and cross connection	The proposed equipment for OTN Cross Connect shall be single chassis based. The proposed equipment shall be able to extend the configuration by multiple shelves managed under single NE.		

**Volume- II**

<b>Make Offered:</b>				
<b>Model Offered:</b>				
<b>S. No.</b>	<b>Parameter</b>	<b>Minimum Specifications</b>	<b>Compliance Yes/No</b>	<b>Pg. No in Supporting Doc.</b>
2.	OTN switching and cross connection	The system shall support mapping of client to OTN as follow: 10GE -> ODU2 100GE -> ODU4 100GE->ODU4C2		
3.	OTN switching and cross connection	The client/line card shall provide ODUFlex mapping such as 80xODU0->ODU4 -8xODU0->ODU2		
4.	OTN switching and cross connection	The system shall provide OTN switching capacity The OTN switching capacity shall be aptly chosen on basis of the service matrix.		
5.	OTN switching and cross connection	The OTN Switching capacity shall be scalable/upgradable to higher capacity by cascading or by installing new higher capacity switching card in the same shelf.		
6.	OTN switching and cross connection	The bidder shall quote the price as an optional item for the additional interface/cards/modules and license to cascade or to upgrade to higher switching capacity.		
7.	OTN switching and cross connection	OTN switching solution shall support fully redundant cards.		
8.	OTN switching and cross connection	The system shall support bidirectional cross-connects.		
9.	OTN switching and cross connection	The solution shall support OTN switching to enable switching and grooming of traffic onto the 100G/200G Line side.		
10.	OTN switching and cross connection	The OTN switch shall be able to aggregate and switch 10G, 100G, STM64, ODU-4 client ports mapped into and 100G Line Card.		
11.	OTN switching and cross connection	The OTN switch shall be able to configure and switch 100G OTN client ports mapped into ODU-4 (that supports 100GbE, ODU4).		
12.	OTN switching and cross connection	The OTN protection switching time in the offered DWDM network shall be less than 50ms.		
13.	OTN switching and cross connection	The system shall support a level of protection, such as APS Linear or path protection.		

<b>Make Offered:</b>				
<b>Model Offered:</b>				
<b>S. No.</b>	<b>Parameter</b>	<b>Minimum Specifications</b>	<b>Compliance Yes/No</b>	<b>Pg. No in Supporting Doc.</b>
14.	OTN switching and cross connection	The system shall support OTU, ODU bidirectional loopbacks.		
15.	OTN switching and cross connection	The OTN control plane restoration must be supported on the system		
16.	OTN switching and cross connection	Protection schemes and mechanism		
17.	OTN switching and cross connection	The system shall support channel protection in linear, ring and mesh network topology.		
18.	OTN switching and cross connection	The Bidder shall provide Protection switching due to signal degrade conditions		
19.	OTN switching and cross connection	System shall support protection scheme to guarantee less than 50ms switching time in case of fibre link failures in the network.		
20.	OTN switching and cross connection	The system shall support revertive, non-revertive and manual protection switching.		
21.	OTN switching and cross connection	The offered equipment shall have at least N:1 redundancy of OTN Switching Card.		

Table 17: Specifications for OTN

**1.1.8 Server**

<b>Make Offered:</b>				
<b>Model Offered:</b>				
<b>S. No.</b>	<b>Parameter</b>	<b>Minimum Specifications</b>	<b>Compliance Yes/No</b>	<b>Pg. No in Supporting Doc.</b>
1.	Processor	Latest series/ generation of 64 bit x86 processor(s) with 10 or higher Cores		
		Processor speed should be minimum 2.4 GHz		
		Minimum 2 processors per each physical server		
2.	RAM	Minimum 64 GB Memory per physical server		
3.	Internal Storage	2 x 300 GB SAS Drives		

**Volume- II**

<b>Make Offered:</b>				
<b>Model Offered:</b>				
<b>S. No.</b>	<b>Parameter</b>	<b>Minimum Specifications</b>	<b>Compliance Yes/No</b>	<b>Pg. No in Supporting Doc.</b>
4.	Network interface	2 X 10GbE LAN ports for providing Ethernet connectivity		
		Optional: 1 X Dual-port 16Gbps FC HBA for providing FC connectivity		
5.	Power supply	Dual Redundant Power Supply		
6.	RAID support	As per requirement/solution		
7.	Operating System	Licensed version of 64 bit latest version of Linux/ Unix/Microsoft® Windows based Operating system)		
8.	Form Factor	Rack mountable/ Blade		
9.	Virtualization	Shall support Industry standard virtualization hypervisor like Hyper-V, VMWARE and Citrix.		

*Table 18: Specification for Servers*

**1.1.9 Blade Chassis**

<b>Make Offered:</b>				
<b>Model Offered:</b>				
<b>S. No.</b>	<b>Minimum Specification</b>	<b>Compliance Yes/No</b>	<b>Pg. No in Supporting Doc.</b>	
1	Minimum 6U size, rack-mountable, capable of accommodating minimum 8 or higher hot pluggable blades			
2	Dual network connectivity of 10 G speed for each blade server for redundancy shall be provided			
3	Backplane shall be completely passive device. If it is active, dual backplane shall be provided for redundancy.			
4	Have the capability for installing industry standard flavours of Microsoft Windows, and Enterprise Red Hat Linux OS as well as virtualization solution such as VMware.			
5	DVD ROM shall be available in chassis, can be internal or external which can be shared by all the blades allowing remote installation of software			
6	Minimum 1 USB port			
7	Two hot-plug/hot-swap, redundant 10 Gbps Ethernet or FCoE module with minimum 16 ports (cumulative), having Layer 2/3 functionality			
8	Two hot-plugs/hot-swap redundant 16 Gbps Fibre Channel module for connectivity to the external Fibre channel Switch and ultimately to the storage device			
9	Hot plug/hot-swap redundant power supplies to be provided, along with power cables			

Make Offered:			
Model Offered:			
S. No.	Minimum Specification	Compliance Yes/No	Pg. No in Supporting Doc.
10	Power supplies shall have N+N. All power supplies modules shall be populated in the chassis.		
11	Required number of PDUs and power cables, to connect all blades, Chassis to Data Centre power outlet.		
12	Hot pluggable/hot-swappable redundant cooling unit		
13	Provision of systems management and deployment tools to aid in blade server configuration and OS deployment		
14	Blade enclosure shall have provision to connect to display console/central console for local management such as troubleshooting, configuration, system status/health display.		
15	Single console for all blades in the enclosure, built-in KVM switch or Virtual KVM features over IP		
16	Dedicated management network port shall have separate path for remote management.		

Table 19: Specifications for Blade Chassis

### 1.1.1 Primary Storage

Make Offered:				
Model Offered:				
S. No.	Parameter	Minimum Specifications	Compliance Yes/No	Pg. No in Supporting Doc.
1	Solution/ Type	IP Based/iSCSI/FC/NFS/CIFS		
2	Storage	Storage Capacity should be minimum 280 TB (usable, after configuring in offered RAID configuration)		
		RAID solution offered must protect against double disc failure.		
		Disks should be preferably minimum of 3 TB capacity		
		To store all types of data (Data, Voice, Images, Video, etc)		
3	Hardware Platform	Rack mounted form-factor		
		Modular design to support controllers and disk drives expansion		
4	Controllers	At least 2 Controllers in active/active mode		
		The controllers / Storage nodes should be upgradable seamlessly, without any disruptions / downtime to production workflow for performance, capacity enhancement and software / firmware upgrades.		



## Volume- II

Make Offered:				
Model Offered:				
S. No.	Parameter	Minimum Specifications	Compliance Yes/No	Pg. No in Supporting Doc.
5	RAID support	RAID 0, 1, 1+0, 5+0 and 6		
6	Cache	Minimum 64 GB of useable cache across all controllers. If cache is provided in additional hardware for unified storage solution, then cache must be over and above 64 GB.		
7	Redundancy and High Availability	The Storage System should be able to protect the data against single point of failure with respect to hard disks, connectivity interfaces, fans and power supplies		
8	Management software	All the necessary software (GUI Based) to configure and manage the storage space, RAID configuration, logical drives allocation, snapshots etc. are to be provided for the entire system proposed.		
		Licenses for the storage management software should include disc capacity/count of the complete solution and any additional disks to be plugged in in the future, upto max capacity of the existing controller/units.		
		A single command console for entire storage system.		
		Should also include storage performance monitoring and management software		
		Should provide the functionality of proactive monitoring of Disk drive and Storage system for all possible disk failures		
9	Data Protection	The storage array must have complete cache protection mechanism either by de-staging data to disk or providing complete cache data protection with battery backup for up to 4 hours		

Table 20: Specifications for Primary storage

### 1.1.1 Secondary Storage

Make Offered:				
Model Offered:				
S. No.	Parameter	Minimum Specifications	Compliance Yes/No	Pg. No in Supporting Doc.
1.	Solution/Type	Secondary Storage (Archival/Backup) can be on any media such as Disks, Disk systems, etc. or its combination. (so as to arrive at lower cost per TB)		
		May or may not use de-duplication technology		
		Compatible with primary storage		

## Volume- II

Make Offered:				
Model Offered:				
		Must use latest stable technology platform, with support available for next 7 to 10 years.		
2.	Backup Size	To store data as required, to meet the archival requirement for different type of data/information		
3.	Hardware Platform	Rack mounted, Rack based Expansion shelves		
4.	Software Platform	Must include backup/archive application portfolio required		
5.	Retrieval Time	Retrieval time for any data stored on secondary storage should be max. 4 hours for critical data & 8 hours for other data. This would be taken into account for SLA calculation. (Critical data means any data needing urgent attention by the Authority).		

Table 21: Specifications for Secondary Storage

### 1.1.1 Enterprise Management System (EMS)

The Enterprise Management System (EMS) is an important requirement of this Project. Various key components of the EMS are:

- § SLA & Contract management System
- § Network Monitoring System
- § Server Monitoring System
- § Helpdesk System

Proposed EMS Solution shall be based on industry standard best practice framework such as ITIL etc.

Make Offered:				
Model Offered:				
S. No.	Parameter	Minimum Specifications	Compliance Yes/No	Pg. No in Supporting Doc.
1.	General	The EMS shall support capability for monitoring and configuration of DWDM based Optical and IP/MPLS network through NOC		
		EMS shall support single management system for optical and IP/MPLS network to provide ease of operation.		
		EMS shall be capable of providing the FCAPS functionality to the network. EMS shall provide all necessary information to NMS on standard interfaces.		
		EMS for Network Elements shall support northbound open interfaces such as SNMP/JAVA/CORBA/XML for integration with the NMS.		
		The EMS system shall support SNMPv1, v2 & v3.		

**Volume- II**

<b>Make Offered:</b>				
<b>Model Offered:</b>				
<b>S. No.</b>	<b>Parameter</b>	<b>Minimum Specifications</b>	<b>Compliance Yes/No</b>	<b>Pg. No in Supporting Doc.</b>
		EMS shall support client-server based architecture. Client being GUI/web browser based access with secure interface to the server.		
		EMS should allow the user to zoom down to the port level of any given card /equipment.		
		EMS should support Scheduler to handle administrative operations to be performed repeatedly at a particular time of day. Such as: NE configuration backup, software image download, operator login/logout attempts, etc.		
		EMS must support below network element software management:-		
		a. Loading of new software images.		
		b. Management of multiple versions of software		
		c. Installation of software updates.		
		d. Software download status reporting.		
		e. Administrator authorization for the loading of software		
		f. Coordination for the software download to multiple end element based on a single software source.		
		g. Version control for all network		
		h. Administrator authorization for the loading of software		
		The EMS GUI should allow authorised personnel to create and activate end-to-end services.		
		The EMS should be able to provision, configure and manage network for DWDM and IP/MPLS		
		EMS should allow service and equipment provisioning.		
		The Management System shall be able to auto-discover the Network elements and the corresponding connections between them.		
		The EMS should support provision of creation, addition, deletion, updation and viewing capability of the managed network		
		The system should support health monitoring of all modules and indicate health of the system and connectivity.		
		The Management System shall support the provisioning of :-		
		a. All equipment parameters.		
		b. Threshold Crossing Alert(TCA) Alarm Severity		
		Alarms should be categorised into different categories e.g. Emergency/Critical, Flash/Major, Immediate/Minor, Priority/Warning,		

**Volume- II**

<b>Make Offered:</b>				
<b>Model Offered:</b>				
<b>S. No.</b>	<b>Parameter</b>	<b>Minimum Specifications</b>	<b>Compliance Yes/No</b>	<b>Pg. No in Supporting Doc.</b>
		Deferred/Informative depending upon the severity of the alarm.		
		EMS should be able to display the Network Elements and the links in different colours depending upon their status for healthy, degraded and critical alarm conditions.		
		Dashboard should indicate the number of active alarms with filtering options based on the period, duration, severity, event type and location.		
		The NMS system should support email or SMS feature for informing user		
		All failure and restoration events should be time-stamped.		
		The GUI shall provide the ability to create, delete and modify topology views of the network.		
		EMS should be based on open, secure, and scalable software for optimizing network infrastructure and operations		
		EMS Should support editing that provides the ability to view, edit, and delete all aspects of a device's configuration.		
		EMS should support audit logs		
		EMS Should support rapid deployment of DWDM based Optical and IP/MPLS network.		
		EMS Should support APIs for customization and integration.		
		The system should be able to create performance reports and Alarm reports. These reports shall be HTML or pdf which can be dynamically generated and sent over e-mail.		
		The system should allow creation of group profiles with multiple users as member and should facilitate with similar access policy and permission.		
		The EMS should support RADIUS/TACACS based access control		
2.	SLA & Contract Management	The SLA & Contract Management solution should enable the Authority to capture all the System based SLAs defined in this Tender and then calculate quarterly (or for any duration) penalty automatically. Measuring service performance requires incorporation of a wide variety of data sources of the project. The SLA solution should support the collection data from various sources in order to calculate Uptime / Performance / Security SLAs. Various features required in this component to EMS are -		

Make Offered:				
Model Offered:				
S. No.	Parameter	Minimum Specifications	Compliance Yes/No	Pg. No in Supporting Doc.
		It must be a centralized monitoring solution for all IT assets (including servers, network equipment etc.)		
		The solution must have integrated dashboard providing view of non performing components / issues with related to service on any active components		
		The solution must follow governance, compliance and content validations to improve standardization of service level contracts		
		Application should be pre-configured so as to allow the users to generate timely reports on the SLAs on various parameters.		
		The solution must support Service Level Agreements & Lifecycle Management including Version Control, Status Control, Effectively and audit Trail to ensure accountability for the project.		
		The solution must have the ability to define and calculate key performance indicators from an End to End Business Service delivery perspective related to the Project under discussion.		
		The solution should support requirements of the auditors requiring technical audit of the whole system		
		The solution must have an integrated dashboard, view of Contract Parties & current SLA delivery levels and view of Services & current SLA performance		
		The solution should support SLA Alerts escalation and approval process.		
		Solution should support effective root cause analysis, support capabilities for investigating the root causes of failed service levels and must make it possible to find the underlying events that cause the service level contract to fail.		
		Accept Data from a variety of formats; provide pre-configured connectors and adapters, Ability to define Adapters to data source in a visual manner without coding.		
		Support for Defining and Calculating service Credit and Penalty based on clauses in SLAs.		
3.	Reporting	Ability to generate reports on penalty and credit due, to check on non-compliance of SLAs for the the project		
		Monetary penalties to be levied for non-compliance of SLA, thus the system must provide Service Level Performance Report over time, contract, service and more.		
		The solution should provide historical and concurrent service level reports for the project in order to ensure accountability of the service provider's performance		

Make Offered:				
Model Offered:				
S. No.	Parameter	Minimum Specifications	Compliance Yes/No	Pg. No in Supporting Doc.
		Automatic Report creation, execution and Scheduling, must support variety of export formats including Microsoft Word, Adobe PDF etc.		
		The solution must support Templates for report generation, Report Filtering and Consolidation and Context sensitive Drill-down on specific report data to drive standardization and governance of the project		
		The solution must support security for drill-down capabilities in dashboard reports ensuring visibility for only relevant personnel of the project		
		Support real-time reports as well as historical analysis reports (like Trend, TopN, Capacity planning reports etc.)		
		a. Resource utilization exceeding or below customer-defined limits		
		b. Resource utilization exceeding or below predefined threshold limits		
		An indicative List of SLAs that need to be measured centrally by SLA contract management system are given in the Tender Document. These SLAs must be represented using appropriate customizable reports to ensure overall service delivery.		
4.	Network Management System	Solution should provide Fault, Configuration & Performance management of the entire datacentre infrastructure and should monitor IP/SNMP enabled devices such as Routers, Switches, Cameras, Online UPS, etc. Proposed Network Management shall integrate with SLA & Contract Management system in order to supply KPI metrics like availability, utilisation in order to measure central SLA's and calculate penalties. Following are key functionalities that are required, which will help measuring SLA's as well as assist administrators to monitor network faults & performance degradations in order to reduce downtimes, increase availability and take proactive actions to remediate & restore network services.		
		The proposed solution must automatically discover manageable elements connected to the infrastructure and map the connectivity between them. Solution should provide centralized monitoring console displaying network topology map from central location to node level.		
		Proposed solution should provide customizable reporting interface to create custom reports for collected data.		
		The system must use advanced root-cause analysis techniques and policy-based condition correlation technology for comprehensive analysis of infrastructure faults.		

Make Offered:				
Model Offered:				
S. No.	Parameter	Minimum Specifications	Compliance Yes/No	Pg. No in Supporting Doc.
		The system should be able to clearly identify configuration changes as root cause of network problems and administrators should receive an alert in case of any change made on routers spread across project.		
		Network Performance management system should provide predictive performance monitoring and should be able to auto-calculate resource utilisation baselines for the entire managed systems and networks and allow user to set corresponding upper and lower threshold limits based on baseline data instead of setting up manual thresholds for monitored devices.		
		The system must support the ability to create reports that allow the network administrators to search all IP traffic over a specified historical period, for a variety of conditions for critical router interfaces.		
		The proposed system must be capable of providing the following detailed analysis across network domain:		
		a. Top utilised links (inbound and outbound) based on utilisation of link		
		b. Top protocols by volume based on utilisation of link		
		c. Top host by volume based on utilisation of link		
5.	Server Performance Monitoring System	The proposed tool should integrate with network performance management system and support operating system monitoring for various platforms supplied as part of the project.		
		The proposed tool must provide information about availability and performance for target server nodes.		
		The proposed tool should be able to monitor various operating system parameters such as processors, memory, files, processes, file systems, etc. where applicable.		
		The solution should provide a unified web based console, which consolidates all aspects of role based access under a single console.		
		Proposed Network Management shall integrate with SLA & Contract Management system in order to supply KPI metrics like availability, utilization, and performance in order to measure central SLA's and calculate penalties.		
6.	Centralized Helpdesk	The proposed helpdesk solution must provide flexibility of logging, viewing, updating and closing incident manually via web interface for issues related to project.		

Make Offered:				
Model Offered:				
S. No.	Parameter	Minimum Specifications	Compliance Yes/No	Pg. No in Supporting Doc.
		Helpdesk system should provide incident management, problem management templates along with helpdesk SLA system for tracking SLA's pertaining to incident resolution time for priority / non-priority incidents.		
		The proposed helpdesk solution must have a built-in workflow engine to define escalations or tasks to be carried out after issues or change order are logged pertaining to the project.		
		Centralized Helpdesk System should have integration with Network/Server Monitoring Systems so that the Helpdesk Operators can associate alarms with Service Desk tickets to help operators that for what particular alarms corresponding helpdesk tickets got logged.		
		Network admin should be able to manually create tickets through Fault Management GUI.		
		System should also automatically create tickets based on alarm type		
		System should provide a link to directly launch a Service Desk view of a particular ticket created by alarm from within the Network Operation console.		

Table 22: Specifications for EMS

**1.1.13 PON EMS**

Make Offered:				
Model Offered:				
S. No.	Parameter	Minimum Specifications	Compliance Yes/No	Pg. No in Supporting Doc.
1.	General	The management system shall be able to auto-discover the network including the network elements.		
		The management system shall provide access using remote clients that use HTTP.		
		The functionalities of the offered NMS and EMS system shall cover these management layers:		
		Network Element Management Layer: This shall manage the Network Elements such as their configuration, alarms or performance.		
		Network Management Layer: This shall manage end-to-end network connectivity, network level protection, network level paths and performance and other network level issues.		
		The NMS must support a northbound interface.		



Make Offered:				
Model Offered:				
S. No.	Parameter	Minimum Specifications	Compliance Yes/No	Pg. No in Supporting Doc.
2.	GUI	The offered NMS system shall employ Graphical User Interface that allows users to manage the network through a multilevel window. (i.e. Network and Sub networks Maps window).		
		The offered NMS system shall allow the Users to perform, but not restricted to, the following operations on the Network and Sub network Maps:		
		View the alarm conditions of the OLT's, ONTs, MDUs		
		View the performance parameters of an individual link		
		Zoom in and out on the Network Map including the ability to define a custom sub- network map. The graphical user interface shall provide a cascading menu and a graphical display of the shelf layout that allows users to move from shelf to board to port menus and execute commands for that menu.		
		The Graphical User Interface shall provide an End-to-end Network view that could span sub networks.		
3.	Configuration Management	The offered NMS shall support managing ports (enable / disable).		
		The offered NMS shall support the ability to perform a remote inventory.		
		Software Management: This shall include the ability to download software loads, activate new software loads, or get information about the active software load).		
		The offered NMS shall provide the facility to perform backup & restore of the node configuration via non-volatile memory on the OLT or via the NMS database.		
4.	Fault Management	Users shall have the ability to define customizable alarms in terms of severity levels and filtering.		
		Alarms shall be consistent in terms of marking them with appropriate colors.		
		There shall be mechanisms to provide for fault isolation.		
		There shall be connectivity and loopback testing capability in all technologies to help isolate faults.		
		There shall be alarm correlation to prevent a flood of alarms.		
		Equipment alarms shall be localized up to the board and port level of a specific shelf of a specific node.		
		The alarms shall be audible and/or bring up a pop-up window if appropriate.		
		The NMS shall allow users to create a Trouble Ticket for any alarms. This trouble ticket should allow users to enter comments on that alarm.		

Make Offered:				
Model Offered:				
S. No.	Parameter	Minimum Specifications	Compliance Yes/No	Pg. No in Supporting Doc.
		There shall be a provision to run diagnostics on network elements, cards or links manually.		
		There shall be scheduler to run diagnostics at certain times and report problems as alarms.		
		A scheduler shall also be available to collect performance metrics from network elements to the network management system.		
5.	Event Logging	There shall be a mechanism for alarms and logging including all user actions.		
		The logging shall be customizable for specific types of events or alarms.		
6.	Performance Management	The management system shall provide the ability to set thresholds on performance metrics and generate alarms from these thresholds.		
		The management system shall provide capacity planning reports that provide long-term traffic analysis to help in deciding whether to upgrade links or nodes.		
7.	Security Management	Illegal access to the management system shall be prevented; all users shall have a User Id and Password, which defines their access level with the management system.		
		The offered NMS system shall allow for Domain creation and partitioning, each domain being a different access level of part of the network or different function.		
		It shall be possible to assign specific users to a particular domain, so the domain access can be restricted to the assigned users only.		
		Users assigned to a specific Domain shall have different levels of authorization (i.e. different functions and privileges).		
		Local access via the Local Craft Terminal to any managed Network Element or node shall be controlled by the network management system.		
		The management system shall be able to detect a Local Craft Terminal connection to any Network element or node.		
8.	Management features & functionalities	Additions of OLT's/MDU's to the NMS shall not require any licenses as long as the maximum capacity of the proposed NMS is not reached.		
		The NMS shall not require any licenses for the hosted CPE (ONT).		

Make Offered:				
Model Offered:				
S. No.	Parameter	Minimum Specifications	Compliance Yes/No	Pg. No in Supporting Doc.
		The Local craft Terminal (LCT) license shall be of unlimited use		
		Software updates including maintenance versions shall be free of cost for the next two years.		
		The Network Management proposal shall include all the Hardware and software requirements including servers, work station, PC, system and third party software licenses and services.		
		It should be possible to download software remotely, with or without NMS. For upgrade/downgrade purposes, the offered product should have active memory and standby memory for ease of upgrade/downgrade.		
		It should be possible to downgrade a software in the offered system/ Network Element		
		Bidder shall provide a matrix table showing the compatibility of different NMS versions with different OLT/MDU software versions and different Hardware versions.		
		The offered management system shall be equipped with the XML, SNMP and TMF CORBA open and standard interfaces for easy integration. The bidder shall specify the management procedure and interface for the local and remote management of the offered system.		
		All the related telecom industry supported standards shall be quoted to support the above.		

Table 23: Specifications for GPON EMS

**1.1.14 Core switch**

Make Offered:				
Model Offered:				
S. No.	Parameter	Minimum Specifications	Compliance Yes/No	Pg. No in Supporting Doc.
1.	Ports	The switch should have a throughput of Min. 1.2 Tbps		
		All ports can auto-negotiate between all allowable speeds, half-duplex or full duplex and flow control for half-duplex ports		
		The uplink must support 100-Gbps OR 40-Gbps ports, or a combination of 10-, 40-, and 100-Gbps connectivity,		
2.	Switch type	Layer 3		
3.	MAC	Support 128 K MAC address.		

**Volume- II**

<b>Make Offered:</b>				
<b>Model Offered:</b>				
<b>S. No.</b>	<b>Parameter</b>	<b>Minimum Specifications</b>	<b>Compliance Yes/No</b>	<b>Pg. No in Supporting Doc.</b>
4.	Backplane	Capable of providing wire-speed switching		
5.	Throughput	500 Mpps or better		
6.	Port Features	Must support Port Mirroring, Port Trunking and 802.3ad LACP Link Aggregation port trunks		
7.	Flow Control	Support IEEE 802.3x flow control for full-duplex mode ports.		
8.	Protocols	IPV4, IPV6		
		Support 802.1D, 802.1S, 802.1w, Rate limiting		
		Support 802.1Q VLAN encapsulation, IGMP v1, v2 and v3 snooping		
		802.1p Priority Queues, port mirroring, DiffServ		
		DHCP support		
		Support up to 4000 VLANs		
		Support IGMP Snooping and IGMP Querying		
		Support Multicasting		
		Should support Loop protection and Loop detection, Should support Ring protection		
9.	Access Control	Support port security		
		Support 802.1x (Port based network access control).		
		Support for MAC filtering.		
		Should support TACACS+ and RADIUS authentication		
10.	VLAN	Support 802.1Q Tagged VLAN and port based VLANs and Private VLAN		
		The switch must support dynamic VLAN Registration or equivalent		
		Dynamic Trunking protocol or equivalent		
11.	Protocol and Traffic	Network Time Protocol or equivalent Simple Network Time Protocol support		
		Switch should support traffic segmentation		
		Traffic classification should be based on user-definable application types: TOS, DSCP, Port based, TCP/UDP port number		
12.	Management	Switch needs to have a console port for management via a console terminal or PC		
		Must have support SNMP v1,v2 and v3		
		Should support 4 groups of RMON		
		Should have accessibility using Telnet, SSH, Console access, easier software upgrade through network using TFTP etc. Configuration management through CLI, GUI based software utility and using web interface		

Make Offered:				
Model Offered:				
S. No.	Parameter	Minimum Specifications	Compliance Yes/No	Pg. No in Supporting Doc.
13.	Resiliency	Dual load sharing AC and DC power supplies		
		Redundant variable-speed fans		
14.	High Availability	Switch must have modular chassis. It must have 2 dedicated supervisor slots		
		Switch must support online insertion and removal of all the parts like modules, power supplies and fan trays etc. without any traffic disruption, performance degradation and rebooting of switch.		
		Switch must have redundant (N+N /N+1) Power supply, FAN tray, Supervisor engines and Fabric Modules.		
15.	Routing Protocol	Complete Layer 3 unicast and multicast routing protocol suites are supported, including BGP, Open Shortest Path First (OSPF), Routing Information		
		Protocol Version 2 (RIPv2), Protocol Independent Multicast sparse mode (PIM-SM), Source-Specific Multicast (SSM), and Multicast Source Discovery Protocol (MSDP). Multiprotocol Label Switching (MPLS).		
17.	Certification	The proposed router or family of router should be NDPP/ EAL certified by common Criteria body.		

Table 24: Specification for Core Switch

### 1.1.15 Aggregation Switch

Make Offered:				
Model Offered:				
S No.	Parameter	Minimum Specifications	Compliance Yes/No	Pg. No in Supporting Doc.
1.	Ports	24 or 48 (as per density required) 1G/ 10G Ethernet ports (as per internal connection requirements) and extra 2 numbers of Uplink ports (40GE)		
		All ports can auto-negotiate between all allowable speeds, half-duplex or full duplex and flow control for half-duplex ports.		
2.	Switch type	Layer 3		
3.	MAC	Support 32K MAC address.		
4.	Backplane	Capable of providing wire-speed switching		
5.	Throughput	200 Mpps or better		
6.	Port Features	Must support Port Mirroring, Port Trunking and 802.3ad LACP Link Aggregation port trunks		
7.	Flow Control	Support IEEE 802.3x flow control for full-duplex mode ports.		
8.	Protocols	IPV4, IPV6		

Make Offered:				
Model Offered:				
S No.	Parameter	Minimum Specifications	Compliance Yes/No	Pg. No in Supporting Doc.
		Support 802.1D, 802.1S, 802.1w, Rate limiting		
		Support 802.1X Security standards		
		Support 802.1Q VLAN encapsulation, IGMP v1, v2 and v3 snooping		
		802.1p Priority Queues, port mirroring, DiffServ		
		DHCP support		
		Support up to 1024 VLANs		
		Support IGMP Snooping and IGMP Querying		
		Support Multicasting		
		Should support Loop protection and Loop detection,		
		Should support Ring protection		
9.	Access Control	Support port security		
		Support 802.1x (Port based network access control).		
		Support for MAC filtering.		
		Should support TACACS+ and RADIUS authentication		
10.	VLAN	Support 802.1Q Tagged VLAN and port based VLANs and Private VLAN		
		The switch must support dynamic VLAN Registration or equivalent		
		Dynamic Trunking protocol or equivalent		
11.	Protocol and Traffic	Network Time Protocol or equivalent Simple Network Time Protocol support		
		Switch should support traffic segmentation		
		Traffic classification should be based on user-definable application types: TOS, DSCP, Port based, TCP/UDP port number		
12.	Management	Switch needs to have a console port for management via a console terminal or PC		
		Must have support SNMP v1,v2 and v3		
		Should support 4 groups of RMON		
		Should have accessibility using Telnet, SSH, Console access, easier software upgrade through network using TFTP etc. Configuration management through CLI, GUI based software utility and using web interface		
13.	Resiliency	Dual load sharing AC and DC power supplies		
		Redundant variable-speed fans		

Table 25: Specifications for Aggregation Switch

1.1.1 Access Switch

Make Offered:				
Model Offered:				
S No.	Parameter	Minimum Specifications	Compliance Yes/No	Pg. No in Supporting Doc.
1.	Ports	24 or 48 (as per requirements) 10/100/1000 Base-TX Ethernet ports/FX Ports and extra 2 numbers of Base-SX/LX ports		
		FX/TX Splits for a switch as per location requirement		
		All ports can auto-negotiate between 10Mbps/ 100Mbps/ 1000Mbps, half-duplex or full duplex and flow control for half-duplex ports.		
2.	Switch type	Layer 2/3		
3.	MAC	Support 16K MAC address (as per solution offered).		
4.	Backplane	50 Gbps or more Switching fabric capacity for 24 ports.		
		100 Gbps or more Switching fabric capacity for 48 ports		
5.	Forwarding rate	Packet Forwarding Rate should be 70.0 Mbps or better		
6.	Port Features	Must support Port Mirroring, Port Trunking and 802.3ad LACP Link Aggregation port trunks		
7.	Flow Control	Support IEEE 802.3x flow control for full-duplex mode ports.		
8.	Protocols	Support 802.1D, 802.1S, 802.1w, Rate limiting		
		Support 802.1X Security standards		
		Support 802.1Q VLAN encapsulation, IGMP v1, v2 and v3 snooping		
		802.1p Priority Queues, port mirroring, DiffServ		
		Support based on 802.1p priority bits with at least 8 queues		
		DHCP support & DHCP snooping/relay/optional 82/ server support		
		Shaped Round Robin (SRR) or WRR scheduling support		
		Support for IPV6 ready features with dual stack		
		Support up to 255 VLANs and up to 4K VLAN IDs		
		Support IGMP Snooping and IGMP Querying		
		Support Multicasting		
9.	Access Control	Support port security		
		Support 802.1x (Port based network access control).		
		Support for MAC filtering.		
		Should support TACACS+ and RADIUS authentication		

Make Offered:				
Model Offered:				
S No.	Parameter	Minimum Specifications	Compliance Yes/No	Pg. No in Supporting Doc.
10.	VLAN	Support 802.1Q Tagged VLAN and port based VLANs and Private VLAN		
		The switch must support dynamic VLAN Registration or equivalent		
		Dynamic Trunking protocol or equivalent		
11.	Protocol and Traffic	Network Time Protocol or equivalent Simple Network Time Protocol support		
		Switch should support traffic segmentation		
		Traffic classification should be based on user-definable application types: TOS, DSCP, Port based, TCP/UDP port number		
12.	Management	Switch needs to have RS-232/USB console port for management via a console terminal or PC		
		Must have support SNMP v1,v2 and v3		
		Should support 4 groups of RMON		
		Should have accessibility using Telnet, SSH, Console access, easier software upgrade through network using TFTP etc. Configuration management through CLI, GUI based software utility and using web interface		

Table 26: Specifications for Access Switch

**1.1.1 GPON OLT**

Make Offered:				
Model Offered:				
S No.	Parameter	Minimum Specification	Compliance Yes/No	Pg. No in Supporting Doc.
1.	Generic Requirements	FTTx solution should be based on GPON		
2.	Service Interfaces	GPON, 2.5G downstream, 1.25G upstream.		
		The equipment must be able to operate at the physical distance of 20 km (between OLT and ONU/ONT) without any additional amplification required.		
		The OLT should support 1310 and 1490 nm wavelengths		
		No. Of Subscribers per GPON port support is 64 (Splitting ratio 1:64)		
		The FTTx platform shall be modular, with minimum of 40Gbps switching capacity.		
		The Interfaces for the offered FTTx systems shall be of "plug in type (PIU) SFP modules"		



Make Offered:				
Model Offered:				
S No.	Parameter	Minimum Specification	Compliance Yes/No	Pg. No in Supporting Doc.
		The offered OLTs/MDUs/HGWs shall be interoperable with any third party ONTs as per the OMCI standards and must at least be certified by the Broadband Forum BBF.247. Inter-operability tests shall be done with different vendors		
3.	Network Management	Unified Network Management system (NMS) shall be offered		
		The required NMS in addition to management of network elements shall be incorporated optionally with special network planning and management tools for managing all connections through the FTTx network and modelling, planning and span design for FTTx networks etc.		
		Bidder shall offer Network Management System for the offered equipment to provide the capabilities for configuration, operation, monitoring, remote monitoring, fault localization, and data storage.		
4.	FTTx System General Requirements	Should be compliant to the relevant ISO/ETSI industry quality standards (e.g. ISO 9000/9001), defining the quality system requirements for the design, development, production, delivery, installation and maintenance of product and services.		
		The offered equipment shall be able to inter-work with the other user end equipment supplied by other vendors as per ITU-T specifications. It should follow standard G.984.8		
		The offered equipment shall support single fibre operation on standard SMF G.652, G.655 & G.657.		
		The IGMP forwarding capabilities on OLT should be no less than 2000pps,		
		The equipment shall support IPv4 and IPv6.		
		The equipment shall detect the optical power transmission of every ONT, once that it detects some problems in the status of the optical transmission power.		
5.	VLAN operations support	Mapping of subscriber VLAN to a common service VLAN		
		Mapping of the subscriber traffic based on the IEEE 802.1p priority tagging to a specific VLAN.		
		Mapping of the subscriber traffic based on the IEEE 802.1Q VLAN ID to a specific VLAN		
		Mapping of the subscriber traffic based on the combination of IEEE 802.1p and 802.1Q tagging to a specific VLAN		

Make Offered:				
Model Offered:				
S No.	Parameter	Minimum Specification	Compliance Yes/No	Pg. No in Supporting Doc.
6.	Subscriber Access methods supported	DHCP, DHCP option 82/60/43/37/18 Static IP, PPPoE		
		Shall support multiple service delivery of data, voice and video.		
		Shall support IP policing at the network and subscriber end.		
		Shall support Ethernet 802.1p and IP TOS bit prioritization.		
		The OLTs shall be able to support mobile traffic backhauling.		
		Support for the Building Integrated Timing Supply (BITS), 10 MHz and 1 pulse per second (1PPS) interfaces. Supports synchronous Ethernet (SyncE) and IEEE-1588 functionalities, and Shall act as the source for network clocking for TDM, SDH and SONET and SyncE interfaces. In addition to the timing services		
7.	QoS Features supported	The Equipment must support IP Multicasting to cater for interactive services such as broadcast IPTV, distance learning, etc. The detail implementation of multicasting mechanism must be explained.		
		Trusted connectivity where the QoS setting / traffic prioritization configured by customer can be preserved.		
		Un-trusted connectivity where the QoS setting / traffic prioritization configured by customer can be overwritten by the Equipment.		
		The detail Downstream and Upstream QoS and traffic prioritization mechanism supported inclusive of the hardware queue available for each direction. A minimum of 8 hardware queues should be supported at both directions. The OLT should implement some queuing mechanism to manage the hardware queue such as SP, WRR, etc.		
		Management System shall support bandwidth provisioning starting from 64 kbps granularity.		
7.	QoS Features supported	Shall support Dynamic Bandwidth Allocation (DBA) mechanism to allow optimum bandwidth utilization on each PON interface. The detail implementation and capability of DBA mechanism should be explained in detail.		
		The offered NG-PON equipment shall support a complete T-Cont type (Type 1, 2, 3, and 4) according to ITU-T G.983.4. The bidder shall explain the T-		

**Volume- II**

<b>Make Offered:</b>				
<b>Model Offered:</b>				
<b>S No.</b>	<b>Parameter</b>	<b>Minimum Specification</b>	<b>Compliance Yes/No</b>	<b>Pg. No in Supporting Doc.</b>
		Cont types supported and typical usage of each of it respectively.		
		Shall support basic OAM features such as loop back, remote diagnostic, CC and Link Trace complies with IEEE 802.1ag.		
8.	ITU-T / IEEE Related Specifications	Shall comply to ITU-T/IEEE recommendations.		
		ITU-T G.652: Characteristics of a single-mode optical fibre and cable.		
		ITU-T G.757: Characteristics of a Bending Loss Insensitive Single Mode Optical Fibre and Cable for the Access Network		
		ITU-T G.703: Physical/electrical characteristics of hierarchical digital interface.		
		ITU-T G.704: Synchronous frame structures used at 1544, 6312, 2048, 8448 and 44 736 Kbit/s hierarchical levels.		
		ITU-T G.823: The control of jitter and wander within digital networks which are based on the 2048 Kbit/s hierarchy.		
		ITU-T G.983.4: A broadband optical access system with increased service capability using dynamic bandwidth assignment.		
		ITU-T G.984.1: GPON General Characteristics.		
		ITU-T G.984.2: GPON Physical Media Dependent (PMD) layer specification.		
		ITU-T G.984.3: GPON Transmission convergence layer specification.		
		ITU-T G.984.8: GPON ONT management and control interface specification.		
		ITU-T G.987.1: XG-PON, General requirements.		
		ITU-T G.987.2: XG-PON, Physical media dependent (PMD) layer specification.		
		ITU-T G.987.3: XG-PON, Transmission convergence (TC) specifications		
		ITU-T G.988: XG-PON, ONU management and control interface (OMCI) specification		
		ITU-T G.8261: Timing and Synchronization aspects in packet networks.		
IEEE 802.1ad Provider Bridges				
IEEE 802.1ag Ethernet OAM				
IEEE 802.1D Spanning Tree Protocol				

Make Offered:				
Model Offered:				
S No.	Parameter	Minimum Specification	Compliance Yes/No	Pg. No in Supporting Doc.
		IEEE 802.1p VLAN prioritization		
		IEEE 802.1Q VLAN tagging		
		IEEE 802.1w Rapid Spanning Tree Protocol of at least 8 ports, based on port-based, address-based, and round robin		
		IEEE 802.1p VLAN prioritization.		
		IEEE 802.1Q VLAN tagging.		
		IEEE 802.3 10 Mbps Ethernet		
		IEEE 802.3u 100 Mbps Fast Ethernet		
		IEEE 802.3ad Ethernet Link Aggregation		
		IEEE 802.3ae 10 Gigabit Ethernet		
		IEEE 802.3z Gigabit Ethernet		
		IEEE 802.3x Flow Control		
		IETF RFC 2131: DHCP		
		IETF RFC 2236: Internet Group Management Protocol, Version 2.		
		IETF RFC 3046: DHCP Relay Agent Info Option (Option 82)		
		IETF RFC 3376: Internet Group Management Protocol, Version 3		
Any other standards inter-related with all the above Specifications and any other standards deemed necessary by the bidder.				
9.	OLT Hardware features	The OLT shall be rack mountable and meet ETSI standards for indoor equipment requirement.		
		The OLT shall be designed to Operate at 210- 250 V ac		
		Dual Redundant Power supplies		
		Operating temperature: 0 to 65 centigrade		
		Fan is required for cooling the OLT to force airflow.		
		The OLT shall provide one craft port for local configuration access.		
		The OLT shall support one 10/100M Ethernet port for linking with EMS.		
		The equipment must support a minimum splitting ratio of 32 splits or more.		
10.	Physical interfaces supported/loaded	Supporting Ethernet interfaces towards the FTTx network is the mandatory requirement.		
		The offered OLT should support minimum 4 GPON interfaces, 4 x 1G SFP interfaces, 2 x 10 G SFP+ interfaces		

**Volume- II**

<b>Make Offered:</b>				
<b>Model Offered:</b>				
<b>S No.</b>	<b>Parameter</b>	<b>Minimum Specification</b>	<b>Compliance Yes/No</b>	<b>Pg. No in Supporting Doc.</b>
		The offered OLT should be expandable to support additional 4 x GPON interfaces		
11.	TEC GR	The technical specification applicable for GPON equipment under the scope of this tender is as per the TEC GR No. GR/PON-01/02 APRIL 2008 with all amendments.		
		The constituents of GPON network shall be as per TEC GR No. GR/PON-01/02 APRIL 2008 with all amendments along with the following modifications as per the requirement of tenderer. In case of any conflict in interpretation of this GR, specifications of this tender supersedes GR		

*Table 27: Specifications for GPON OLT*

**1.1.1 GPON ONT**

<b>Make Offered:</b>				
<b>Model Offered:</b>				
<b>S. No.</b>	<b>Minimum Specification</b>	<b>Compliance Yes/No</b>	<b>Pg. No in Supporting Doc.</b>	
1	Should support four GigE interface			
2	Should support Wire speed data transfer			
3	Should support Per-subscriber, per-service bandwidth control			
4	Should support IP video with multistage Internet Group Management			
5	Should support Protocol (IGMP) v2/v3 for channel change			
6	Should support received signal strength indication (RSSI) for lean operations and remote troubleshooting			
7	Should support advanced dynamic bandwidth management allows prioritization per service and user with the ability to burst up to the full line rate. This guarantees very high quality of service and future security, and makes optimal use of electronics, fibre optics and distribution facilities support on ONT			
8	PON interface should support SC/APC optical connector			
9	Operating Temperature: 0°C to 50°C			
10	Relative humidity: 5% to 95%			
11	Local powering with 12V input , AC power supply			
12	ONT should support Dying gasp			
13	Power consumption: <4W			

## Volume- II

Make Offered:			
Model Offered:			
S. No.	Minimum Specification	Compliance Yes/No	Pg. No in Supporting Doc.
14	Height: 120mm, Width: 90mm, Depth: 33mm, Weight: 0.12kg, Wall or desk mount		
15	LED: Power, Alarm, Connection, Ethernet		
16	EMI: Protection of over voltage/current		
17	Functional and technical requirement of ONT shall be as per TEC GR no. GR/PON-01/02 APRIL 2008 and latest amendments. In case of any conflict in interpretation of this GR, specifications of this tender supersedes GR.		

Table 28: Specifications for GPON ONT

### 1.1.19 Workstation

Make Offered				
Model Offered				
Sl. No.	Parameter	Minimum Specifications	Compliance Yes/No	Pg. No. in Supporting Document
1.	Processor	Latest generation 64bit X86 Quad core processor(3.33 Ghz) or better		
2.	Chipset	Latest series 64bit Chipset		
3.	Motherboard	OEM Motherboard		
4.	RAM	Minimum 8 GB DDR3 ECC Memory @ 1600 Mhz.. Slots should be free for future upgrade. Minimum 4 DIMM slots, supporting up to 32GB ECC		
5.	Graphics card	WHQL certified Graphics card with 2 GB video memory (non- shared).		
6.	HDD	2 TB SATA-3 Hard drive @7200 rpm		
7.	Media Drive	NO CD / DVD Drive		
8.	Network interface	1000BaseT, Gigabit Ethernet (10/100/1G auto sensing)		
9.	Audio	Line/Mic IN, Line-out/Spr Out (3.5 mm)		
10.	Ports	Minimum 6 USB ports (out of that 2 in front). These would be disabled for data transfer.		
11.	Keyboard	104 keys minimum OEM keyboard		
12.	Mouse	2 button optical scroll mouse (USB)		

## Volume- II

Make Offered				
Model Offered				
Sl. No.	Parameter	Minimum Specifications	Compliance Yes/No	Pg. No. in Supporting Document
13.	Monitor	22" TFT LED monitor, Minimum 1920 x1080 resolution, 5 ms or better response time, TCO 05 (or higher) certified		
14.	Certification	Energy star 5.0/BEE star certified		
15.	Operating System	64 bit pre-loaded OS with recovery disc		
16.	Security	BIOS controlled electro-mechanical internal chassis lock for the system.		
17.	Antivirus feature	Advanced antivirus, antispymware, desktop firewall, intrusion prevention (comprising of a single, deployable agent) which can be managed by a central server. (Support, updates, patches and errata for the entire contract/ project period)		
18.	DLP/DRM Software	There would be DRM Software/application installed on these workstations that would prevent unauthorized copying of sensitive data.		
19.	Operation System and Support	Pre-loaded Windows 10 (or latest) Professional 64 bit, licensed copy with certificate of authenticity (or equivalent authenticity information) and all necessary and latest patches and updates. Can be downgraded to Windows 7 Professional (64 bit). All Utilities and driver software, bundled in CD/DVD/Pen-drive media		

Table 29: Specifications for Workstation

### 1.1.2 Desktop

Make Offered				
Model Offered				
Sl. No.	Parameter	Minimum Specifications	Compliance Yes/No	Pg. No. in Supporting Document
1.	Processor	Intel Core i7-latest generation (3.0 Ghz) or higher OR AMD A10 7850B (3.0 Ghz) processor or higher OR Equivalent 64 bit x86 processor		
2.	Memory	8 GB DDR3 RAM @ 1600 MHz. One DIMM Slot must be free for future upgrade		

## Volume- II

Make Offered				
Model Offered				
Sl. No.	Parameter	Minimum Specifications	Compliance Yes/No	Pg. No. in Supporting Document
3.	Motherboard	OEM Motherboard		
4.	Hard Disk Drive	Minimum 1 TB SATA III Hard Disk @7200 RPM or higher		
5.	Audio	Line/Mic In, Line-out/Speaker Out (3.5 mm)		
6.	Network port	10/100/1000 Mbps auto-sensing on-board integrated RJ-45 Ethernet Port		
7.	USB Ports	Minimum 4 USB ports (out of that 2 must be in front)		
8.	Display Port	1 Display Port (HDMI/VGA ) port		
9.	Power supply	Maximum Rating 250 Watts, 80 plus certified power supply		
10.	Keyboard	104 keys Heavy Duty Mechanical Switch Keyboard (USB Interface) with 50 million keystrokes life per switch. Rupee Symbol to be engraved.		
11.	Mouse	Optical with USB interface (same make as desktop)		
12.	Monitor	Minimum 21.5" diagonal LED Monitor with 1366x768 or higher resolution. (Same make as desktop). Must be TCO05 certified		
13.	Operation System and Support	Pre-loaded Windows 10 (or latest) Professional 64 bit, licensed copy with certificate of authenticity (or equivalent authenticity information) and all necessary and latest patches and updates. Can be downgraded to Windows 7 Professional (64 bit). All Utilities and driver software, bundled in CD/DVD/Pen-drive media		
14.	Certification for Desktop	Energy Star 5.0 or above / BEE star certified		

Table 30: Specifications for Desktop

### 1.1.2 Network Colour Laser Printer

Make Offered:				
Model Offered:				
S No.	Parameter	Minimum Specifications	Compliance Yes/No	Pg. No in Supporting Doc.
1.	Print Speed	Black : 16 ppm or above on A3, 24 ppm or above on A4		
		Colour : 8 ppm or above on A3, 12 ppm or above on A4		
2.	Resolution	600 X 600 DPI		



**Volume- II**

<b>Make Offered:</b>				
<b>Model Offered:</b>				
<b>S No.</b>	<b>Parameter</b>	<b>Minimum Specifications</b>	<b>Compliance Yes/No</b>	<b>Pg. No in Supporting Doc.</b>
3.	Memory	8 MB or more		
4.	Paper Size	A3, A4, Legal, Letter, Executive, custom sizes		
5.	Paper Capacity	250 sheets or above on standard input tray, 100 Sheet or above on Output Tray		
6.	Duty Cycle	25,000 sheets or better per month		
7.	OS Support	Linux, Windows 2000, Vista, 7, 8, 8.1		
8.	Interface	Ethernet Interface		

*Table 31: Specifications for Network colour laser printer*

**1.1.22P Phone & IP PBX**

<b>Make Offered:</b>				
<b>Model Offered:</b>				
<b>S No.</b>	<b>Parameter</b>	<b>Minimum Specifications</b>	<b>Compliance Yes/No</b>	<b>Pg. No in Supporting Doc.</b>
1.	Display	2 line or more, Monochrome display for viewing features like messages, directory etc.		
2.	Integral switch	10/100 mbps for a direct connection to a 10/100BASE-T Ethernet network through an RJ-45 interface		
3.	Speaker Phone	Yes		
		Full duplex speaker phone with echo cancellation		
		Speaker on/ off button, microphone mute		
4.	Head set	Port for Head set (Headset also to be provided)		
5.	VoIP Protocol	SIP V2		
6.	PoE	IEEE 802.3af or better		
7.	Supported Protocols	SNMP, DHCP, DNS		
8.	Codecs	G.711, G.722 including handset and speakerphone		
9.	Volume Control	Easy decibel level adjustment for speaker phone, handset and ringer		
10.	Phonebook/ Address book	Minimum 100 contacts		
11.	Call Logs	Access to missed, received, and placed calls. (Minimum 20 overall)		
12.	Clock	Time and Date on display		
13.	Ringer	Selectable Ringer tone		
14.	Directory Access	LDAP standard directory		
15.	IP PBX	IP PBX to support minimum 500 IP Phones with at least 100 concurrent sessions with features like –		

Make Offered:				
Model Offered:				
S No.	Parameter	Minimum Specifications	Compliance Yes/No	Pg. No in Supporting Doc.
		Provide reports for calls based on records, calls on a user basis, calls through gateways etc.		
		Able to add bulk add, delete, and update operations for devices and users		
		Session Initiation Protocol (SIP) Trunk support		
		Centralized, configuration database, Web based management		
		Lightweight Directory Access Protocol (LDAP) directory interface		
		Facilities to users like Call Back, Call Forward, Directory Dial, Last number Redial, etc.		
		Calling Line Identification		

Table 32: Specifications for IP Phone & IP PBX

### 1.1.2 Helpdesk

Make Offered:				
Model Offered:				
S No.	Parameter	Minimum Specifications	Compliance Yes/No	Pg. No in Supporting Doc.
1.	Automatic Call Distribution (ACD)	Routing of the calls to available agent would be done by ACD.		
		ACD would employ a rule based routing strategy		
		ACD should be able to identify available agents and transfer the call accordingly		
		Call routing to the agents based on the “longest idle basis”		
		ACD shall seamlessly integrate with IP PBX system		
		When a call is transferred to the IP phone then the call details should also be simultaneously transferred to CAD software in a pre-defined format.		
2.	Call Telephony Integration (CTI)	Allow interaction between telephone and a computer to be integrated or coordinated.		
		Shall act as a common interface for integration of all the software applications deployed.		
		Shall support relevant screen pop-ups on the agents’ screen on the basis of call location detection		
		Shall pass events & information of agents’ status & changes in agent status as well as incoming calls to the computer applications		

Make Offered:				
Model Offered:				
S No.	Parameter	Minimum Specifications	Compliance Yes/No	Pg. No in Supporting Doc.
3.	Interactive Voice Recording System (IVRS)	Shall help caller in interaction with voice and DTMF (Dual tone multi-frequency signalling) via keypad. Through the IVRS system, caller would easily be able to direct the concern to appropriate agent at the helpdesk		
		IVRS shall be able to queue the calls and provide position number in queue and approximate time to reach agent		
		Shall support English and Malayalam languages		
4.	IP PBX	IP PBX software allows transferring calls received on PRI lines to the IP network.		
		IP PBX shall ring the IP phone of the identified agent		
		Provision to broadcast "Greeting Message" whenever a call is received on the system		

Table 33: Specifications for Helpdesk

### 1.1.24 Video Wall / Video Screen

Make Offered:				
Model Offered:				
S No.	Parameter	Minimum Specifications	Compliance Yes/No	Pg. No in Supporting Doc.
1.	Technology	Solid state LED illumination technology or Direct LED IPS based Technology or equivalent		
2.	Display Unit	The Visual Display Unit / Rear Projection Module must be based on Single Chip Rear Projection Technology. Should have the scalability and upgradeability to be made up of multiple rear projection modules stacked up in columns to achieve a display wall for better viewing ability in linear or curved configuration.		
3.	Display Controller	Video Distributor, Display controller to control Video wall in a matrix as per requirement with necessary software:		
		Processor specs: Quad core 64-bit, 3.4 GHz CPU or latest		
		RAM: 8 GB DDR3 minimum		
		HDD: Min 500 GB Hard Disk (Hard disk Capacity should be upgradable)		
		Network support: Gigabit Ethernet Controller inbuilt, Support for Add on Network adapters.		
		Videowall Display: Display multiple source windows in any size, anywhere on the wall		
		Accessories: DVD-R,DVD+RW,, Keyboard, mouse		
OS Support: 64-bit Operating Systems Windows / Linux or equivalent industry standard				

**Volume- II**

<b>Make Offered:</b>				
<b>Model Offered:</b>				
<b>S No.</b>	<b>Parameter</b>	<b>Minimum Specifications</b>	<b>Compliance Yes/No</b>	<b>Pg. No in Supporting Doc.</b>
4.	Screen Size	70" or higher; 3x2 arrangement		
5.	Resolution	Full high definition (1920X1080)		
6.	Brightness	Uniformity of 85%		
7.	Contrast Ratio	Min. 1400 : 1		
8.	Wall Uptime	Min. 60,000 hours of rated life (Expected to be operational 24X7)		
9.	Viewing Angle	180 degree viewing angle		
10.	Screen to Screen gap	The inter screen gap should be <0.6mm.		
11.	Other Features	RS232 control (with loop-through)		
		On Screen Display (OSD)		
		IR remote control		
		flicker free image on the Large Screen Graphics Wall		
		Should be supplied with necessary display controller (if required)		
12.	Input	Analog D-sub/Digital DVI/Digital HDMI (as per solution)		
13.	Management Software	Display & Scaling: Display multiple sources anywhere on display up to any size		
		Input Management: All input sources can be displayed on the video wall in freely resizable and movable windows		
		Scenarios Management: Save and Load desktop layouts from Local or remote machines		
		Layout Management: Support all Layout from Input Sources, Internet Explorer, Desktop and Remote Desktop Application		
		Multi View Option: Multiple view of portions or regions of Desktop, Multiple Application Can view from single desktop		
		Other features:		
		a. SMTP support		
		b. Remote Control over LAN		
		c. Alarm management		
		d. Remote management		
		e. Multiple concurrent client		
f. KVM support				
7. Cube Management:				
a. Cube Health Monitoring				

## Volume- II

Make Offered:				
Model Offered:				
S No.	Parameter	Minimum Specifications	Compliance Yes/No	Pg. No in Supporting Doc.
		b. Pop Up Alert Service		
		c. Graphical User Interface		

Table 34: Specifications for Video Wall

### 1.1.25 Video Management Solution

Video management system shall constitute of a platform which will be designed for viewing, recording and replaying acquired video as part of overall project solution. This platform will be based on the Internet Protocol (IP) open platform concept. Major functionalities are described here:

#### VMS Overview

1. VMS shall be used for centralized management of all PoP camera devices, video servers and client users.
2. The system shall support H.265 or better, MPEG-4 and MJPEG compression formats for all IP cameras connected to the system.
3. VMS server shall be deployed in a clustered server environment/Support in built for high availability and failover for directory & recording servers
4. VMS shall support a flexible rule-based system driven by schedules and events.
5. VMS shall be supported for fully distributed solution for monitoring and control function, designed for limitless multi-site and multiple server installations requiring 24/7 surveillance with support for devices from different vendors.
6. VMS shall support internet protocol (IP) cameras from major vendors.
7. The Contractor shall clearly list in their proposal the make and models that can be integrated with the VMS, additionally all the offered VMS and cameras must have Open Network Video Interface Forum (ONVIF) compliance.
8. VMS shall be enabled for any standard storage technologies and video wall system integration.
9. VMS shall be enabled for integration with any external Video Analytics Systems both edge & Server based
10. VMS shall be capable of being deployed in a virtualized server environment without loss of any functionality.
11. All CCTV cameras locations shall be overlaid in graphical map in the VMS Graphical User Interface (GUI). The cameras selection for viewing shall be possible via clicking on the camera location on the graphical map. The graphical map shall be of high resolution enabling operator to zoom-in for specific location while selecting a camera for viewing.
12. VMS shall have an administrator interface to set system parameters, manage codecs, manage permissions and manage storage.
13. VMS day to day control of cameras and monitoring on client workstations shall be controlled through the administrator interface.
14. Whilst live control and monitoring is the primary activity of the monitoring workstations, video replay shall also be accommodated on the GUI for general review and also for pre- and post-alarm recording display.
15. The solution design for the VMS shall support various video signal compression techniques, display, storage and retrieval.
16. All CCTV camera video signal inputs to the system shall be provided to the NOC.
17. VMS shall be capable of transferring recorded images to recordable media (such as CD/DVD and/or tapes) in tamper evident and auditable form. All standard formats shall be supported including, but not limited to:
  - a) AVI files
  - b) MP4 Export or latest

## Volume- II

---

18. For Video Exports with VMS's Native Format - one can protect the video tampering and prove that the video is not tampered
19. All streams to the above locations shall be available in real-time and at full resolution. Resolution and other related parameters shall be configurable by the administrator in order to provide for network constraints.
20. The VMS shall support field sensor settings. Each channel configured in the VMS shall have an individual setup for the following settings, the specific settings shall be determined according to the encoding device:
  - a) Brightness
  - b) Contrast
  - c) Color
  - d) Sharpness
  - e) Saturation
  - f) Hue
  - g) White balance
21. The VMS shall support the following operations:
  - a) Adding an IP device
  - b) Updating an IP device
  - c) Updating basic device parameters
  - d) Adding/removing channels
  - e) Adding/removing output signals
  - f) Updating an IP channel
  - g) Removing an IP device
  - h) Enabling/disabling an IP channel
  - i) Refreshing an IP device (in case of firmware upgrade)
22. The VMS shall support retrieving data from edge storage. Thus when a lost or broken connection is restored, it shall be possible to retrieve the video from SD card and store it on central storage.
23. The VMS shall support bookmarking the videos. Thus, allowing the users to mark incidents on live and/or playback video streams.
24. VMS shall support automatic failover for recording. Some Critical cameras shall also be supported for Redundant (Mirrored Recording simultaneously)
25. VMS shall support manual failover for maintenance purpose.
26. VMS shall support integration with other online and offline video analytic applications.
27. VMS shall be able to accept alerts from video analytics built into the cameras, other third party systems, sensors etc.
28. System should support recording management to view the recordings available on a camera's local storage device (such as an SD card), and copy them to the server.
29. The VMS shall support replacement of the edge device with another device, while maintaining past recordings according to the defined retention period and device logical entities association (triggers association, pages, etc.)
30. The VMS shall support LoS (Level of Service) mechanism, choosing between several video streams according to its performance parameters and networking capabilities of the workstation and/or decoder.
31. The VMS recorders' performance shall support 100% of recording channels, 30% of the channels with live monitoring and 20% of the channels with playbacks all at the same time.

### Client system

The Client system shall provide remote users with rich functionality and features as described below.

1. Viewing live video from cameras on the surveillance system
2. Browsing recordings from storage systems
3. Creating and switching between multiple of views.

## Volume- II

---

4. Viewing video from selected cameras in greater magnification and/or higher quality in a designated hotspot.
5. Using digital zoom on live as well as recorded video.
6. Using sound notifications for attracting attention to detected motion or events.
7. Getting quick overview of sequences with detected motion.
8. Getting quick overviews of detected alerts or events.
9. Quickly searching selected areas of video recording for motion (also known as Smart Search).
10. The VMS shall use its own streaming server to efficiently stream the videos.
11. When the VMS client is set to view the live videos in say 3x3, 4x4 and 5x5 grids, the VMS should display lower resolution, high frame rate video to avoid high bandwidth and CPU usage on the VMS client
12. When the user selects a particular camera, and wants to view it in full screen, the VMS should automatically show the highest quality and high frame rate video.

### Mobile Client

The Contractor shall be required to provide a standardized Mobile Application to integrate smart phones and tablets for communication with the Video Management System/control center in a secure manner. It shall be possible for a field operator to click pictures, record videos, send text messages of the crime scene/incident location etc. and send them to the NOC. It will be the responsibility of the contractor to configure such tablets / Smartphone with the Surveillance System and ensure that all the necessary access is given to these mobile users. Communication between Mobile Client and Server shall be encrypted with Digital Certificates.

### Alarm Monitoring

1. The VMS shall allow for continuous monitoring of the operational status and event-triggered alarms from various system servers, cameras and other devices. It shall provide a real-time overview of alarm status or technical problems while allowing for immediate visual verification and troubleshooting.
2. It shall provide interface and navigational tools through the client including;
3. Graphical overview of the operational status and alarms from servers, network cameras and external devices including motion detectors and access control systems.
4. Intuitive navigation using a map-based, hierarchical structure with hyperlinks to other maps, servers and devices or through a tree-view format.
5. It shall include flexible access rights and allow each user to be assigned several roles where each shall define access rights to cameras.
6. Basic VMS should be capable to accept third party generated events / triggers

### Other functionality

1. The System shall offer centralized management of all devices, servers and users.
2. The System should not have any limit on the number of cameras to be connected for Surveillance, Monitoring and recording. Any increase in the no. of cameras should be possible by augmentation of Hardware components.
3. The System shall support distributed viewing of any camera in the system using Video walls or big screen displays.
4. It should be possible to integrate the System with 3<sup>rd</sup> party software, to enable the users to develop customized applications for enhancing the use of video surveillance solution. For e.g., integrating alarm management to initiate SMS, E-Mail etc.
5. System should be able to be integrated with PSIM / Incident Management System.
6. The System Administration Server shall provide a feature-rich administration client for system configuration and day-to-day administration of the system.
7. The System Administration Server shall support different logs related to the Management Server.
  - a) The System Log
  - b) The Audit Log

## Volume- II

- c) The Alert Log
  - d) The Event Log
8. Rules: The system shall support the use of rules to determine when specific actions occur. Rules shall define what actions shall be carried out under specific conditions. The system shall support rule-initiated actions such as:
- a) Start and stop recording
  - b) Set non-default live frame rate
  - c) Send notifications via email
  - d) Pop-up video on designated Client Monitor recipients
- ξ Security Platform shall have strong security mechanism such as the use of advance encryption, digital certificates and claims-based authentication to ensure that only authorized personnel have access to critical information, prevent man-in-the-middle attacks, and that the data is kept private.

### Failover & Redundancy

1. Synchronized Failover directory feature should be provided with the offered system to avoid the single point of failure. Also the system should sustain all its current operations i.e. recording, playback and live video even in the event of primary as well as failover directory failure. This functionality can either be loaded on any of the recording server or on a dedicated server. If offered software need dedicated server for this, then the same will be in contractor's scope. Specifications of failover administration server should be same as that of recording server except storage size.
2. Automated Failover recording should be provided to maintain the reliability of the system. In case of failure of one or more of primary recording servers simultaneously. Additional servers/storage required to meet this requirement should be in Contractors scope.
3. Redundant recording/Dual recording feature of the VMS should be supported by VMS. System administrator should get the privilege to configure this feature on any cameras simultaneously depend on the criticality of the cameras.
4. The VMS shall allow for 2-way audio communication using amplifier/call station connected the IP cameras in the field without any need of audio cabling from camera to control room

### 1.1.2 LCD Projector

Make Offered:				
Model Offered:				
S No.	Parameter	Minimum Specifications	Compliance Yes/No	Pg. No in Supporting Doc.
1.	Display Technology	Poly-silicon TFT LCD		
2.	Resolution	HD 1080p		
3.	Colours	16.7 million Colours		
4.	Brightness	2500 or more ANSI lumens (in Normal Mode)		
5.	Contrast Ratio	2000:1 or more		
6.	Video Input	One computer (D-Sub, Standard 15 pin VGA connector)		
		One S-Video		
		One HDMI		
7.	Audio	Internal speaker		
8.	Output ports	External Computer Monitor port, audio ports		



## Volume- II

Make Offered:				
Model Offered:				
S No.	Parameter	Minimum Specifications	Compliance Yes/No	Pg. No in Supporting Doc.
9.	Remote Operations	Full function Infrared Remote Control		
10.	Other features	Auto source detect, Auto-synchronisation, Keystone Correction		

Table 35: Specifications for LCD projector

### 1.1.2 KVM Module (If required)

Make Offered:				
Model Offered:				
S No.	Parameter	Minimum Specifications	Compliance Yes/No	Pg. No in Supporting Doc.
1.	KVM Requirement	Keyboard, Video Display Unit and Mouse Unit (KVM) for the IT Infrastructure Management at Data Centre		
2.	Form Factor	19" rack mountable		
3.	Ports	minimum 8 ports		
4.	Server Connections	It should support both USB and PS/2 connections.		
5.	Auto-Scan	It should be capable to auto scan servers		
6.	Rack Access	It should support local user port for rack access		
7.	SNMP	The KVM switch should be SNMP enabled. It should be operable from remote locations		
8.	OS Support	It should support multiple operating system		
9.	Power Supply	It should have dual power with failover and built-in surge protection		
10.	Multi-User support	It should support multi-user access and collaboration		

Table 36: Specifications for KVM Module

### 1.1.2 Online UPS

Make Offered:				
Model Offered:				
S No.	Parameter	Minimum Specifications	Compliance Yes/No	Pg. No in Supporting Doc.
1.	Capacity	Adequate capacity to cover all above IT Components at respective location		
2.	Output Wave Form	Pure Sine wave		
3.	Input Power Factor at Full Load	>0.90		

**Volume- II**

<b>Make Offered:</b>				
<b>Model Offered:</b>				
<b>S No.</b>	<b>Parameter</b>	<b>Minimum Specifications</b>	<b>Compliance Yes/No</b>	<b>Pg. No in Supporting Doc.</b>
4.	Input	Single Phase for below 10 KVA		
		Three Phase 3 Wire for over 10 KVA		
5.	Input Voltage Range	305-475VAC at Full Load		
6.	Input Frequency	50Hz +/- 3 Hz		
7.	Output Voltage	400V AC		
		Single Phase for below 10 KVA		
		Three Phase for over 10 KVA		
8.	Output Frequency	50Hz +/- 0.5% (Free running); +/- 3% (Sync. Mode)		
9.	Inverter efficiency	>90%		
10.	Over All AC-AC Efficiency	>85%		
11.	UPS shutdown	UPS should shutdown with an alarm and indication on following conditions 1)Output over voltage 2)Output under voltage 3)Battery low 4)Inverter overload 5)Over temperature 6)Output short		
12.	Battery Backup	30 minutes in full load		
13.	Battery	VRLA (Valve Regulated Lead Acid) SMF (Sealed Maintenance Free) Battery		
14.	Indicators & Metering	Indicators for AC Mains, Load on Battery, Fault, Load Level, Battery Low Warning, Inverter On, UPS on Bypass, Overload, etc.		
		Metering for Input Voltage, Output Voltage and frequency, battery voltage, output current etc.		
15.	Audio Alarm	Battery low, Mains Failure, Over temperature, Inverter overload, Fault etc.		
16.	Cabinet	Rack / Tower type		
17.	Operating Temp	0 to 50 degrees centigrade		
18.	Management Protocol	SNMP Support through TCP/IP		

*Table 37: Specifications for Online UPS*

1.1.2 DG Set

Make Offered:				
Model Offered:				
S No.	Parameter	Minimum Specifications	Compliance Yes/No	Pg. No in Supporting Doc.
1	General Specifications	Auto Starting DG Set mounted on a common base frame with AVM (Anti-Vibration) pads, residential silencer with exhaust piping, complete conforming to ISO 8528 specifications and CPCB certified for emissions.		
		KVA rating as per the requirement		
2	Engine	Radiator cooled, multi cylinder, 1500 RPM diesel engine, with electronic/manual governor and electrical starting arrangement complete with battery, conforming to BS 5514/ ISO 3046/ IS 10002		
3	Fuel	High Speed Diesel (HSD)		
5	Alternator	Self-exciting, self-regulating type alternator rated at 0.8 PF or better, 415 Volts, 3 Phase, 4 wires, 50 cycles/sec, 1500 RPM, conforming to IS 4722/ BS 5000, Windings of 100% Copper, class H insulation, Protection as per IP 23.		
6	AMF (Auto Main Failure) Panel	AMF Panel fitted inside the enclosure, with the following:		
		It should have the following meters/indicators		
		Incoming and outgoing voltage		
		Current in all phases		
		Frequency		
		KVA and power factor		
		Time indication for hours/minutes of operation		
		Fuel Level in fuel tank, low fuel indication		
		Emergency Stop button		
		Auto/Manual/Test selector switch		
		MCCB/Circuit breaker for short-circuit and overload protection		
		Control Fuses		
		Earth Terminal		
Any other switch, instrument, relay etc. essential for Automatic functioning of DG set with AMF panel				
7	Acoustic Enclosure	The DG set shall be provided with acoustic enclosure / canopy to reduce the sound level and to house the entire DG set (Engine & Alternator set) assembly outside (open-air).		
		The enclosure must be weather resistant powder coated, with insulation designed to meet latest MOEF/CPCB norms for DG sets, capable to withstand Kerala climate. The enclosure must have ventilation system, doors for easy access for maintenance, secure locking arrangement, complete and		

**Volume- II**

<b>Make Offered:</b>				
<b>Model Offered:</b>				
<b>S No.</b>	<b>Parameter</b>	<b>Minimum Specifications</b>	<b>Compliance Yes/No</b>	<b>Pg. No in Supporting Doc.</b>
8	Fuel Tank Capacity	It should be sufficient and suitable for containing fuel for minimum 12 hours continuous operation, Complete with level indicator, fuel inlet and outlet, air vent, drain plug, inlet arrangement for direct filling and set of fuel hoses for inlet and return.		

*Table 38: Specifications for DG set*

**1.1.3.3 Firewall**

<b>Make Offered:</b>				
<b>Model Offered:</b>				
<b>S. No.</b>	<b>Minimum Specification</b>	<b>Compliance Yes/No</b>	<b>Pg. No in Supporting Doc.</b>	
1	The proposed appliance based security platform should be capable of providing comprehensive next generation firewall with application based FW, IPS, Antivirus, Antispam, APT protection and URL filtering functionality in a single appliance from day one.			
2	The proposed appliance must be based on standard computer technology (not ASICs) so that future enhancements and protocols do not require hardware refresh to support			
3	The proposed firewall should support at least 10 Gbps of real-world HTTP throughput with all threat prevention features enabled			
4	The proposed firewall should be provided with high-availability and licences for IPS, AV, AS, APT protection and URL filtering.			
5	The solution must be capable of providing comprehensive reporting as part of the same solution with granular visibility in to applications, threats seen on the network and compromised hosts. The solution must provide			
6	the flexibility to export logs to third party syslog of SNMP servers and also the option of a centralized logging and management system capable of storing all logs.			
7	Ports –Minimum 5 x10 GE			
8	The proposed solution must provide DOS protection capabilities to protect the data centre infrastructure from DOS attacks, including SYN, UDP, ICMP and IP floods. The solution must also provide reconnaissance protection.			

Table 39: Specifications for DC Firewall

**1.1.3 URL Filtering Firewall**

Make Offered:			
Model Offered:			
S. No.	Minimum Specification	Compliance Yes/No	Pg. No in Supporting Doc.
1	The Web Security solution (URL filtering solution) must be an integral part of the proposed security solution.		
2	It is preferred that the solution be a part of a Next-Generation Firewall, which would allow for seamless closed-loop feedback mechanisms for accurate classification of URLs and domains, enhancing overall security posture		
3	The URL Filtering solution must have the flexibility of using either a public- cloud based, constantly updated database or use an on-premise Private Cloud solution, which can be manually updated from the public cloud database		
4	The proposed solution shall support custom URL-categorization		
5	The proposed solution shall support customizable block pages, with a continue option for a certain amount of time		
6	The proposed solution shall support logs populated with end user activity reports for site monitoring within the local solution		
7	The proposed solution shall support URL Filtering policies by AD user, group, machines and IP address/range		
8	The Proposed solution shall support URL filtering which provides a categorical URL database functionality to the device for use as a URL and Web Content filter. URL categories can be used to define security policy, complementing the application level control as well as to define SSL decryption exceptions, to determine quality-of-service policy and more.		
9	The Proposed solution should support a throughput of Minimum 40 Gbps		

Make Offered:			
Model Offered:			
S. No.	Minimum Specification	Compliance Yes/No	Pg. No in Supporting Doc.
10	The Proposed solution shall support Custom URL categories to be created to complement the on-box URL database and address unique customer requirements. Administrators may upload custom URL lists from external files or use Dynamic Block Lists to point to external lists or sources.		
11	The Proposed Solution should support using customizable block pages so that users can be notified that they have violated policy. The page can include references to the username, IP address, the URL attempting to be accessed and the category of the URL. In order to place some of the web activity ownership back in the user's hands, administrators should have two powerful options.		
12	URL filtering continue: when a user accesses a page that potentially violates policy, a block page warning with a "Continue" button can be presented to the user, allowing them to proceed if they feel the site is acceptable.		
13	URL filtering override: requires a user to correctly enter an administrator-set password in order to bypass the block page and continue to their internet destination.		
14	Ports – 10 x 10 GE		

Table 40: Specifications for URL Filtering Firewall

### 1.1.32 Indoor Fixed Dome Camera with PoE at NOC & PoP locations

Make Offered:			
Model Offered:			
S. No.	Minimum Specification	Compliance Yes/No	Pg. No in Supporting Doc.
1	Image sensor : 1/2.7" Progressive Scan CMOS		
2	Lens : 3 to 9 mm or better, DC Iris, motorized		
3	Field of View : 37.5°~103.7°(horizontal), 21.6° ~ 71.2° (vertical), 42.6°~111.21° (diagonal)		
4	Day and Night : Automatic/manual/scheduled		
5	Min. Illumination / Light Sensitivity : Color mode: F1.2 @ 0.5 lux Black and white mode: F1.2@ 0.05 lux		
6	Light sensor: Senses the level of ambient light to determine when to switch day/night mode.		

Make Offered:			
Model Offered:			
S. No.	Minimum Specification	Compliance Yes/No	Pg. No in Supporting Doc.
7	Video Compression : H.265 and Motion JPEG		
8	Audio Compression : G.711 <del>Law</del> , G.711 <del>U</del> Law, G.726		
9	Resolutions and frame rates : 30 fps at 1920x1080 (1080p)		
10	Protocol Support : IPv4, IPv6, TCP/IP, HTTP, DHCP, UDP, DNS, SMTP, RTP, RTSP, SNMP protocols/Should meet all functional requirement of the project		
11	PoE : 802.3af compliant		
12	Environmental Certification and Housing : IP66 and IK10 rated		
13	Camera Should remote Zoom and Auto focus		
14	Camera should support Micro SD/SDHC (up to 32GB) and other preceding standard SD cards		
15	Should be ONVIF compliant		
16	The camera should be automatically discovered and configured when connected to VMS or Network Switch, to set the right network parameters for the video stream on the network		
17	Camera recording resolution: 720 p Video Compression: H.265 FPS: 18 fps Recording: 24x7 Retention required: 30 days		

Table 41: Specifications for Indoor Fixed Dome Camera

### 1.1.3 Antivirus software

Make Offered:			
Model Offered:			
S. No.	Minimum Specification	Compliance Yes/No	Pg. No in Supporting Doc.
1	Shall be able to scan through several types of compression formats.		
2	Must update itself over internet for virus definitions, program updates etc. (periodically as well as in push-updates in case of outbreaks)		
3	Able to perform different scan Actions based on the virus type (Trojan/ Worm, Joke, Hoax, Virus, other)		
4	Shall be able to scan only those file types which are potential virus carriers (based on true file type)		
5	Shall be able to scan for HTML, VBScript Viruses, malicious applets and ActiveX controls		

<b>Make Offered:</b>			
<b>Model Offered:</b>			
<b>S. No.</b>	<b>Minimum Specification</b>	<b>Compliance Yes/No</b>	<b>Pg. No in Supporting Doc.</b>
6	Shall provide Real-time product Performance Monitor and Built-in Debug and Diagnostic tools, and context- sensitive help.		
7	The solution must support multiple remote installations		
8	Shall provide for virus notification options for Virus Outbreak Alert and other configurable Conditional Notification.		
9	Should be capable of providing multiple layers of defence		
10	Shall have facility to clean, delete and quarantine the virus affected files.		
11	Should support scanning for ZIP, RAR compressed files, and TAR archive files		
12	Should support online update, where by most product updates and patches can be performed without bringing messaging server off-line.		
13	Should use multiple scan engines during the scanning process		
14	Should support in-memory scanning so as to minimize Disk IO.		
15	Should support Multi-threaded scanning		
16	Should support scanning of nested compressed files		
17	Should support heuristic scanning to allow rule-based detection of unknown viruses		
18	Updates to the scan engines should be automated and should not require manual intervention		
19	All binaries from the vendor that are downloaded and distributed must be signed and the signature verified during runtime for enhanced security		
20	Updates should be capable of being rolled back in case required		
21	File filtering should be supported by the proposed solution; file filtering should be based on true file type.		

Table 42: Specifications for Antivirus Software



**1.1.34 Database Licenses**

Make Offered:			
Model Offered:			
S. No.	Minimum Specification	Compliance Yes/No	Pg. No in Supporting Doc.
1	Bider needs to provide Licensed RDBMS, enterprise/full version as required for the proposed network and following all standard industry norms for performance, data security, authentication and database shall be exportable in to XML.		

Table 43: Specifications for DB Licenses

**1.1.35 Backup Software**

Make Offered:			
Model Offered:			
S. No.	Minimum Specification	Compliance Yes/No	Pg. No in Supporting Doc.
1	The software shall be primarily used to back up the necessary data that would require backing up would include the various databases that shall be created for the network system, logs and reports.		
2	Scheduled unattended backup using policy-based management for all Server and OS platforms		
3	The software should support on-line backup and restore of various applications and Databases		
4	The backup software should be capable of having multiple back-up sessions simultaneously		
5	The backup software should support different types of backup such as Full back up, Incremental back up, Differential back up, Selective back up, Point in Time back up and Progressive Incremental back up and snapshots		
6	The backup software should support different types of user interface such as GUI, Web-based interface		
7	The Software should support discs and tape storage		

Table 44: Specifications for Backup Software

**1.1.36 GIS Software License**

Preference is for an open source software. All data formats shall be compatible with data/coordinate system of Kerala Spatial Data Infrastructure (KSDI) formats. Guidelines for the same are given in the Appendix.

**Volume- II**

<b>Make Offered:</b>			
<b>Model Offered:</b>			
<b>S. No.</b>	<b>Minimum Specification</b>	<b>Compliance Yes/No</b>	<b>Pg. No in Supporting Doc.</b>
1	The system shall have capability to perform attribute or spatial queries on data from selected sources.		
2	Solution shall ensure that the GIS Map provides complete details of the city in various digital vector layers and allows for zoom in/out, searching, and retrieving information capabilities		
3	The system shall support clipping and/or downloading of raster and vector data by authorized users.		
4	The system shall support server side Geo-processing		
5	The application shall have standard and modern map navigation tools of pan and zoom		
6	The application shall support client requests to print the spatial data.		
7	The system shall be able to support industry-standard data types, industry-standard data formats, unlimited file size or database size, unlimited number of files or tables, and unlimited number of users.		
8	The system shall support geocoding and reverse geocoding		
9	The system shall allow the users to perform advanced spatial analysis like geocoding, routing, buffering and attribute based analysis.		
10	The application shall have standard and modern map navigation tools of pan and zoom.		
11	The system shall have the facility wherein the user can opt to view in 2D or 3D environment.		
12	The system shall be compatible with Google Maps, Bing™ Maps, Micro Station, AutoCAD, MGE, FRAMME, G/Technology, ODBC source.		
13	The System shall support hierarchical legends, and watermarks		
14	The application shall allow users to view the data with different symbology styles like differentiating feature records based on attributes or types, dynamic label generation with conflict detection, and translucency of all raster data and area colour fill.		
15	The system shall allow the user to find Address		
16	The system shall be able to consume real-time enterprise published spatial data. It shall be able to consume the third-party published OGC web-services.		
17	Application shall be OGC compliant for database and shall provision conversion to other database formats.		

Make Offered:			
Model Offered:			
S. No.	Minimum Specification	Compliance Yes/No	Pg. No in Supporting Doc.
18	GIS tool needs to be bought in the name of the Authority and will belong to Authority.		

Table 45: Specifications for GIS Tool

### 1.1.3 Public Addressable System

Make Offered:			
Model Offered:			
S. No.	Minimum Specification	Compliance Yes/No	Pg. No in Supporting Doc.
1	Should have the capability to control individual PAS i.e. to make an announcement at select location (1:1) or multiple locations (1: many). The PAS should also support both, Live and Recorded inputs		
2	Should have Minimum 2 Speaker, to be used in different directions with Minimum 200 Watts of amplification		
3	Should have IP Based connectivity		
4	Access control mechanism would be also required to establish so that the usage (including sound volume) is regulated.		
5	Internal Battery with different charging options (Solar/Mains)		
6	Should support Automatic on/off operation		
7	Should have IP-65 rated for housing		
8	Operating temperature: 0° to 50°C		

Table 46: Specifications for Public Addressable System

### 1.1.3 Project Management Software

Make Offered:			
Model Offered:			
S. No.	Minimum Specification	Compliance Yes/No	Pg. No in Supporting Doc.
1	SI shall procure a licensed project management software in the name of the Authority.		

Table 47: Specifications for Project Management Software

Table 48: Specifications for Video Conferencing

**1.1.3 Fibre Monitoring System**

Make Offered:				
Model Offered:				
S No.	Parameter	Minimum Specifications	Compliance Yes/No	Pg. No in Supporting Doc.
1	Mechanical Requirements	The monitoring unit should have capability of minimum 4 ports which can be scalable to higher number of port counts.		
		DCN access is to be provided through an RJ45 cable or optical SFP interface.		
		The monitor unit is to support an operational temperature range of -5C to +55C.		
		The available mounting brackets and supported rack types have to be listed by the vendor. It has to be possible to mount the monitoring unit in any common rack type (19", 21" and 23").		
2	Performance Requirements	The monitoring unit is to cycle through all the monitor ports and measure the total insertion loss of the link. In case the insertion loss of a link has changed and exceeds one of the preconfigured thresholds, an alarm is to be raised.		
		When a fibre-cut occurs, a fast reaction time is of the essence. As such it is important for the monitor unit to be able to find a fibre-cut fast. As a guideline: in a system where all fibres are monitored, a fibre cut on any of the lines needs to be detected within two minutes.		
		Wavelength to be used for monitoring any one of the listed 1310/1550/1625/1650.		
		The dynamic range of OTDR should be minimum 40db.		
		The optical attenuation of the line fibre has to be measured continuously and the measured attenuation values have to be recorded periodically in a database.		
		It has to be possible to configure threshold alarms for user configurable fibre attenuation degradation.		
		In case a fibre-cut occurs the monitor unit is to periodically and automatically check the status of the port. In case the line is repaired the port is to be set back in-service automatically.		
3	NBI	The device must have the following northbound communication options: - SNMPv3/REST and XML		

Make Offered:				
Model Offered:				
S No.	Parameter	Minimum Specifications	Compliance Yes/No	Pg. No in Supporting Doc.
		All relevant parameters of the monitor unit must be configurable through SNMP. A MIB file for the monitoring unit has to be available on request without any license fee. In particular the following parameters are required to be retrievable through SNMP:		
		o General settings (device type, serial number, SW/HW versions)		
		o Port names		
		o Port state		
		o Link insertion loss		
		o Link length		
		o Reference OTDR curve		
		o Alarms		
4	Management System	Upon detecting a fibre fault the device must be capable of sending an email with the details on the fibre cut to designated email addresses.		
		The network management system has to provide standard compliant northbound interfaces to enable relatively simple integration with any existing and data export to network planning tools, inventory management tools, customer portals, etc.		
		Versions of the network management system must be available for both Windows Server as well as Linux.		
		Northbound interfaces have to be available for		
		o Inventory management data		
		o Performance monitoring data		
		o Alarm data		
		All required licenses for unrestricted use of these northbound interfaces have to be covered by the offer.		
The supported northbound interface formats have to be listed by the vendor. For example Corba, MTOSI, EXCEL, SQL, ESV, SNMP and CSV.				
5	Optical ports	SC/LC PC/APC connectors		
6	Count of Optical port	Min 4 ports Scalable up for higher port count		
7	Live & dark fibre monitoring	Live fibre monitoring with >3db insertion end to end loss		
8	Software user interface	CLI / GUI		

## Volume- II

Make Offered:				
Model Offered:				
S No.	Parameter	Minimum Specifications	Compliance Yes/No	Pg. No in Supporting Doc.
9	OTDR Dynamic range 1	Should provide $\geq 28$ dB fibre Km/port,		
10	Pulse width	5ns to 20 $\mu$ s		
11	Fibre loss measurement accuracy	$\pm 1$ dB (at link loss < 30 dB and link length < 90 km) $\pm 1.5$ dB (otherwise)		
12	Power supply	Should support AC or DC input power supply, Power consumption 15 W		
13	operational temperature range	-5C to +55C		
14	mounting brackets and supported rack	Slandered 19-inch, 21-inch, 23-inch		
15	standard compliant northbound interfaces	Integration with EMS, Helpdesk, GIS, inventory management System etc.		
16	Network management system with FMS	Windows / Linux		

Table 49: Specifications for Fibre Monitoring System

### 1.1.40 Integrated Building Management Solution

Make Offered:			
Model Offered:			
S. No.	Minimum Specification	Compliance Yes/No	Pg. No in Supporting Doc.
1	Solution should provide a pre-integrated, centralized and consolidated platform for end to end management of a building, which includes Facility infrastructure (HVACs, LT Panel- AMF, DG, UPS, Fuel Tank, CCTV, Fire Alarm and suppression system, VESDA, etc.). The system should have the service dependency engine that allows to take intelligent decisions, as per the business needs/requirements. The tool should have the service oriented architecture layer and the mediation layer in a single plane. IBMS should be open for third party integration via (soap, xml, web service, snmp-v1, v2, v3). NO/NC ports (IO ports) and Modbus (TCP/IP&RTU) integration should be standard. For other industrial protocols, gateway integration should be available. The solution should perform the following general functions. But should be scalable with ready device certifications to accommodate new infrastructure getting added to the building		

Make Offered:			
Model Offered:			
S. No.	Minimum Specification	Compliance Yes/No	Pg. No in Supporting Doc.
2	It should get a single platform to manage the entire building and its components. The way ahead should be drilling down to the component, which is under performing / about to fail or has failed. The impact of the failed equipment on others should get highlighted. We should get a Hawkeye view to know, how are all the building components working at any point of time. So that issues are addressed as quickly as possible.		
3	End equipment in the building, should be set with thresholds to get an idea of how well they are rendering services to the people in the building. It should be able to proactively Identify potential area's which may need to be upgraded/downgraded (cooling, power, storage, etc.) with time. All vendor (end equipment vendors) SLA's and their respective maintenance contracts would be part of the OMS (operations and maintenance) plan.		
4	Third Party Integration - Seamless Data Sharing to build a "Collaborative Decision making System".		
5	Salient Dependencies - Monitor & Control salient interdependencies between safety and security systems like: In case of fire, other than a fire alarm, we could get confirmatory information from the zonal camera. Multiple current surges in any particular zone should lead to an inspection of the electrical cables in the zone. Any sectional power failure, should help us to find the failure of the end equipment, by tracing down the LT panel SLD to the end equipment.		
6	System with CMDB - Integrate people, process & technology. Decreasing the likelihood of downtime in the building by facilitating communication across all equipment's (part of the facility). A definite inventory management tool with a workflow system connecting responsible people, should be part of the solution.		
7	Root-Cause Analysis - Isolate and pinpoint problem area before it impacts the building operations & business continuity while suppressing down the unwanted events.		
8	Energy sources should always keep in check on the rated power consumption vs the power available for consumption. Since one of the big reasons for fire is higher load than the power distribution capability.		
9	The system should be capable enough to store the raw data or as polled data, for at-least for 365 days. It should also have the facility to automate the backup process or allow to take manual backup, in case if it is required.		
10	The system should be capable of getting supported by the administrators at different levels. The system should provide individual and group rights and privileges. Normal users may have read access only, that too only to specific areas.		
11	Support for email and SMS both (integration with SMS-gateway and GSM communication).		

Make Offered:			
Model Offered:			
S. No.	Minimum Specification	Compliance Yes/No	Pg. No in Supporting Doc.
12	Energy Management: The system should be capable of integrating with the mains (LT panel), DG, UPS, PDU, rectifier, energy meters for continuous monitoring of its health. The battery health of the UPS would also be needed.		
13	System should be able to do continuously monitor the quality of power, supplied to the electricity board and by the Generators (PF, frequency, harmonics distortion etc.), in order to avoid downtime.		
14	System should have the feature to setup thresholds on each of the monitored energy parameter.		
15	System should be able to clearly provide load trend for each rack, if need be in the building which would enable setup practical thresholds to get alerted on overload situations, in order to avoid any breakdown.		
16	Centralized Reporting & Dashboard:		
17	o The dash board and reporting engine should provide centralized view for the entire infrastructure (physical security, safety & energy) in the building.		
18	o It should provide business users with highly interactive and power-users with highly sophisticated, pixel-perfect reports.		
19	o It should provide Web-based interactive reporting for business users, Rich graphical report designer for power users, Parameterized reports with powerful charting, Output in popular formats: HTML, CSV, PDF.		
20	o It should provide Analysis to explore data by multiple dimensions such as customer, product, network and time into the hands of business users.		
21	o The dash board and reporting engine should provide centralized view for the entire infrastructure (physical security, safety & energy) in the building.		
22	o It should provide business users with highly interactive and power-users with highly sophisticated, pixel-perfect reports.		
23	DG Monitoring:		
24	o Proposed system should be able to integrate with diesel generators for measuring fuel level and run hours of the DG. System should also allow monitoring of various alarms (like: LLOP, dg on, etc.) including quality of power of the DG.		
25	o System should be capable to do fuel level monitoring of the diesel tanks installed for the gen-sets in the DC' building, in order to have a proactive estimation of fuel availability.		
26	o Parameters - Generator and Fuel supply Automation		
27	<input type="checkbox"/> Mains Fail		
28	<input type="checkbox"/> DG On		
29	<input type="checkbox"/> DG Failed to start		
30	<input type="checkbox"/> DG Failed to stop		



**Volume- II**

<b>Make Offered:</b>			
<b>Model Offered:</b>			
<b>S. No.</b>	<b>Minimum Specification</b>	<b>Compliance Yes/No</b>	<b>Pg. No in Supporting Doc.</b>
31	<input type="checkbox"/> DG Fuel Level Low		
32	<input type="checkbox"/> High Water Temperature		
33	<input type="checkbox"/> High Coolant Temperature		
34	<input type="checkbox"/> Low Battery Voltage		
35	<input type="checkbox"/> Low Lube Oil Pressure(LLOP)		
36	<input type="checkbox"/> Automate Fuel Supply Process to reduce fuel consumption cost.		

*Table 50: Specifications for Integrated Building Management Solution*

**1.1.4 Rodent Repellent**

<b>Make Offered:</b>			
<b>Model Offered:</b>			
<b>S. No.</b>	<b>Minimum Specification</b>	<b>Compliance Yes/No</b>	<b>Pg. No in Supporting Doc.</b>
1	The entry of Rodents and other unwanted pests shall be controlled using non-chemical, non-toxic devices. Ultrasonic pest repellents shall be provided in the false flooring and ceiling to repel the pests without killing them. However periodic pest control using Chemical spray can be done once in 3 months as a contingency measure to effectively fight the pest menace.		
2	Configuration: Master console with necessary transducer		
3	Operating Frequency: Above 20 KHz (Variable)		
4	Sound Output: 50 dB to 110 dB (at 1 meter)		
5	Power output: 800 mW per transducer		
6	Power consumption: 15 W approximately		
7	Power Supply: 230 V AC 50 Hz		
8	Mounting: Wall / Table Mounting		

*Table 51: Specification for Rodent Repellent System*

**1.1.4 Water Leak Detection System**

Make Offered:				
Model Offered:				
S No.	Parameter	Minimum Specifications	Compliance Yes/No	Pg. No in Supporting Doc.
1.		Water leak detection System should be designed to protect the Air-conditioned premises and to alert the personnel about the leak in the AC systems. The system should be capable of interfacing to Water leak detection sensors, condensation sensors & I/O modules.		
2.		Events should be clearly reported on LCD/LED display with full English language description of the nature of the fault in the panel. The successful bidder should make detailed working drawings and coordinate them with other agencies at site. Water Leak Detection systems should be integrated with BAS.		
3.	Equipment	The Water leak detection system should comprise of Tape Sensors, Water Leak detection modules, Condensation detectors, I/O modules and sounders all connected to a Control Panel.		
4.	Control Panel	The control panel should be computerized 4/8/12 zone multiplex controller with a facility to add on dialer and speech processor. The system should be programmed, armed or disarmed through a control key pad. The control key pad should have a 16 character LCD display for viewing various events. The code to arm or disarm the system should be changed only by entering a master code.		
5.	Control Panel	The system should have 4/8/12 zones and all the detectors should be connected through a 2 core cable. Each area of the premises should be divided into specific zones such that any zone should be isolated by the user if required.		
6.	Control Panel	The entire system should be backed up by a maintenance free rechargeable battery to take care of system's power requirements whenever power fails		
7.	Control Panel	The system should be totally tamper proof and should activate an alarm if the control panel is opened, the sensors tampered with or if the system cables are cut even in the disarmed state.		
8.	Control Panel	The system should log 500 events and optionally printer should be connected for generating reports.		
9.	Control Panel	The Detectors, I/O Modules, Remote Keypads and other Devices should be connected to a system on a single 2/4/6 Core Cable Bus to avoid individual cabling of zones.		
10.	Control Panel	The system should have a Buffer memory of minimum 250 events and log each event with exact date and time.		

Make Offered:				
Model Offered:				
S No.	Parameter	Minimum Specifications	Compliance Yes/No	Pg. No in Supporting Doc.
11.	Control Panel	The controller should have a Serial Port for connecting to a computer.		
12.	Control Panel	The controller should work on 220/240V AC power supply and it should also have a built in battery backup.		
13.	Control Panel	The memory inside the controller should be backed up by a lithium battery. The controller should work effectively over a temperature range of -10 Deg. C to + 55 Deg. C. and 0 to 90% of Humidity.		
14.	Water Leak Detection Sensor	Water Leak Detection sensors should be able to mount in DIN rails, inside AHU's, power distribution units or other equipment where localized leak detection is required. The detectors should be resistant to oxidation and erosion. The detector should have relay output for connection to the controller. LED alarm indication should also be provided. The detectors should operate in AC or DC supply.		
15.	Tape Sensor	Tape sensors are used to detect water leaks usually under floors. Tape sensors for use with water leak detectors should be covered with plastic netting to prevent short circuits when used in metal trays or conduits, and enables the tape to be folded at right angles to allow easy routing.		
16.	Hooter/Sounder	The hooter / sounder should give audible alarm when any sensor operates. It should be complete with electronic oscillations, magnetic coil (sound coil) and accessories ready for mounting (fixing). The sound output from the Hooter should not be less than 85 decibels at the source point.		

Table 52: Specifications for Water Leak Detection System

### 1.1.4 Fire Suppression System

22. The SI shall design, install, and configure the Fire Suppression System for the Data Center area. The Fire Suppression System shall have a clean agent fire suppression system cylinder, seamless cylinders, discharge hose, fire detectors and panels, and all other accessories required to provide a complete operational system, meeting applicable requirements of NFPA 2001 Clean Agent Fire Extinguishing Systems, NFPA 70 National Electric Code, NFPA 72 National Fire Alarm Code, or ISO standards. These standards shall be used to ensure the performance as a system with UL/FM approvals and installed in compliance with all applicable requirements of the local codes and standards.

23. Kyoto Protocols

1. The clean agent system considered for total flooding application shall be in compliance with the provisions of Kyoto Protocol.
2. Care shall be taken that none of the greenhouse gases identified in the Kyoto Protocol is used for fire suppression application.

24. The minimum criteria to select the clean agent shall include following specifications:

**Volume- II**

<b>Make Offered:</b>			
<b>Model Offered:</b>			
<b>S. No.</b>	<b>Minimum Specification</b>	<b>Compliance Yes/No</b>	<b>Pg. No in Supporting Doc.</b>
1.	Zero-ozone depleting potential		
2.	Global-warming potential not exceeding one		
3.	Atmospheric lifetime not exceeding one week		
4.	The clean agent fire suppression system with FK-5-1-12 and inert gas-based systems are accepted as a replacement of HCFC and HFC in accordance with Kyoto Protocol.		
5.	The clean agent considered for the suppression system shall be suitable for occupied areas with No Observable Adverse Effect Level of 10% as compared to the design concentration to ensure high safety margin for the human who might be present in the hazard area		
6.	The minimum design standards shall be in accordance with NFPA 2001, 2004 edition or latest revisions.		
7.	Care shall be given to ensure early warning detection system with minimum sensitivity of 0.03% per foot obscuration in accordance with NFPA 318 and NFPA 72 to ensure a very early warning signal to allow investigation of the incipient fire with significant time before the other detectors activate the fire suppression system automatically.		
8.	All system components furnished and installed shall be warranted against defects in design, materials, and workmanship for the full warranty period, which is standard with the manufacturer, but in no case less than operational readiness closure period.		
9.	Fire suppression system shall deploy NOVEC-based gas suppression systems with cross-zoned detector systems for all locations. These detectors shall be arranged in a manner such that they activate the suppression system in zones to cater to only the affected area.		
10.	Illuminated signs indicating the location of the extinguishers shall be placed high enough to be seen over tall cabinets and racks across the room. A linear heat detection cable shall be placed along all wire pathways in the ceiling. This cable shall not directly trigger the suppression system; rather, it shall prompt the control system to sound an alarm.		
11.	The SI shall give a certificate stating that their NOVEC system is approved by UL/FM/VdS/LPC/CNPP for use with seamless steel cylinders, including component and system approval.		
12.	The SI shall also provide a letter that the OEM has NOVEC flow calculation software suitable for seamless steel cylinder bided for in accordance with the List of Major Components and that such software shall be type approved by UL/FM/VdS/LPC/CNPP.		
13.	The storage container offered shall be of seamless type, meant for exclusive use in NOVEC systems, with UL/FM/VdS/LPC/CNPP-component approval. Welded cylinders are not permitted		
14.	The NOVEC valve shall be differential pressure design and shall not require an explosive- or detonation-type consumable device to operate it.		

<b>Make Offered:</b>			
<b>Model Offered:</b>			
<b>S. No.</b>	<b>Minimum Specification</b>	<b>Compliance Yes/No</b>	<b>Pg. No in Supporting Doc.</b>
15.	The NOVEC valve operating actuators shall be of electric (solenoid) type and shall be capable of resetting manually. The valve shall be capable of being functionally tested for periodic servicing requirements and without any need to replace consumable parts.		
16.	The individual NOVEC bank shall also be fitted with a manual mechanism operating facility that shall provide actuation in case of electric failure.		
17.	The system flow calculation is to be carried out on certified software, suitable for the seamless steel cylinder being offered for this project. Such system flow calculations shall be also approved by UL/FM/VdS/LPC/CNPP.		
18.	The system shall utilize 42-bar/high-pressure (600 psi) technology that allows for a higher capacity to overcome frictional losses, higher distances of the agent flow, and better agent penetration in enclosed electronic equipment such as server racks and electrical panels.		
19.	The designer shall study and address possible fire hazards within the protected volume at the design stage. The delivery of the NOVEC system shall provide for the highest degree of protection and minimum extinguishing time. The design shall be strictly in accordance with NFPA standard NFPA 2001.		
20.	The suppression system shall provide for a high-speed release of NOVEC-based on the concept of total flooding protection for enclosed areas. A uniform extinguishing concentration shall be 7% (v/v) of NOVEC for 21 degrees Celsius or higher as recommended by the manufacturer.		
21.	The system discharge time shall be 10 seconds or less, in accordance with NFPA standard 2001.		
22.	Sub-floor and the ceiling void to be included in the protected volume		
23.	The NOVEC systems to be supplied by The SI shall satisfy all the requirements of the authority having jurisdiction over the location of the protected area and shall be in accordance with the OEM's product design criteria.		
24.	The detection and control system that shall be used to trigger the NOVEC suppression shall employ cross-zoning of photoelectric and ionization smoke detectors. A single detector activated in one zone shall cause an alarm signal to be generated. Another detector activated in the second zone shall generate a pre-discharge signal and start the pre-discharge condition.		
25.	The discharge nozzles shall be located in the protected volume in compliance to the limitation with regard to the spacing, floor and ceiling covering. The nozzle locations shall be such that the uniform design concentration will be established in all parts of the protected volumes. The final number of the discharge nozzles shall be according to the OEM's certified software, which shall also be approved by third-party inspection and certified such as UL/FM/VdS/LPC/CNPP.		

<b>Make Offered:</b>			
<b>Model Offered:</b>			
<b>S. No.</b>	<b>Minimum Specification</b>	<b>Compliance Yes/No</b>	<b>Pg. No in Supporting Doc.</b>
26.	The cylinder shall be equipped with differential pressure valves and no replacement parts shall be necessary to recharge the NOVEC containers.		
27.	NOVEC shall be discharged through the operation of an electric solenoid-operated device or pneumatically operated device, which releases the agent through a differential pressure valve.		
28.	The NOVEC discharge shall be activated by an output directly from the NOVEC gas release control panel, which will activate the solenoid valve. NOVEC agent is stored in the container as a liquid. To aid release and more effective distribution, the container shall be super pressurized to 600 psi (g) at 21°C with dry Nitrogen.		
29.	The releasing device shall be easily removable from the cylinder without emptying the cylinder. While removing from cylinder, the releasing device shall be capable of being operated with no replacement of parts required after this operation.		
30.	Upon discharge of the system, no parts shall require replacement other than gasket, lubricants, and the NOVEC agent. Systems requiring replacement of disks, squibs, or any other parts that add to the recharge cost will not be acceptable.		
31.	The manual release device fitted on the NOVEC cylinders shall be the manual-lever type and a faceplate with clear instruction of how to mechanically activate the system. In all cases, NOVEC cylinders shall be fitted with a manual mechanical operating facility that requires two-action actuation to prevent accidental actuation.		
32.	NOVEC storage cylinder valve shall be provided with a safety rupture disc. An increase in internal pressure due to high temperature shall rupture the safety disc and allow the content to vent before the rupture pressure of the container is reached. The contents shall not be vented through the discharge piping and nozzles.		
33.	NOVEC containers shall be equipped with a pressure gauge to display internal pressure.		
34.	Brass Discharge nozzles shall be used to disperse the NOVEC. The nozzles shall be brass with female threads and available in sizes as advised by the OEM system manufacturer. Each size shall come in 180° and 360° dispersion patterns.		
35.	All the major components of the NOVEC system such as the cylinder, valves and releasing devices, nozzles, and all accessories shall be supplied by one single manufacturer under the same brand name.		
36.	Manual gas discharge stations and manual abort stations, in conformance with the requirements of NFPA 2001, shall be provided.		
37.	Release of NOVEC agent shall be accomplished by an electrical output from the FM-200 gas release panel to the solenoid valve and shall be in accordance with the requirements set forth in the current edition of NFPA 2001.		
38.	A high-sensitivity smoke-detection system shall provide an early warning of fire in its incipient stage, analyze the risk, and set off an		

Make Offered:			
Model Offered:			
S. No.	Minimum Specification	Compliance Yes/No	Pg. No in Supporting Doc.
	alarm and actions appropriate to the risk. The system shall include, but not be limited to, a display control panel, detector assembly, and properly designed sampling pipe network.		

Table 53: Specifications for Fire Suppression System

### 1.1.4 Fire Alarm System

#### 25. System Description

- ξ The Fire alarm system shall be an single loop addressable fire detection and alarm system, and must be installed as per NFPA 72 guidelines.
- ξ Detection shall be by means of automatic heat and smoke detectors (multi sensor) located throughout the Control Room (ceiling, false floor and other appropriate areas where fire can take place) with break glass units on escape routes and exits.

#### 26. Control and indicating component

- ξ The control panel shall be a microprocessor based single loop addressable unit, designed and manufactured to the requirements of UL/EN54 Part 2 for the control and indicating component and UL/EN54 Part 4 for the internal power supply.
- ξ All controls of the system shall be via the control panel only.
- ξ The system status shall be made available via panel mounted LEDs and a backlit 8 line x 40-character alphanumeric liquid crystal display.
- ξ All system controls and programming will be accessed via an alphanumeric keypad. The control panel will incorporate form fill menu driven fields for data entry and retrieval.
- ξ The system will include a detection verification feature. The user shall have the option to action a time response to a fire condition. This time shall be programmable up to 10 minutes to allow for investigation of the fire condition before activating alarm outputs. The operation of a manual call point shall override any verify command.

#### 27. Manual Controls

- ξ Start sounders
- ξ Silence sounders
- ξ Reset system
- ξ Cancel fault buzzer
- ξ Display test
- ξ Delay sounder operation
- ξ Verify fire condition
- ξ Disable loop

#### 28. Smoke detectors – Smoke detectors shall be of the optical or ionization type. Devices shall be compatible with the CIE conforming to the requirements of UL/EN54 Part 7. The detectors shall have twin LEDs to indicate the device has operated and shall fit a common addressable base.

- ξ Heat detectors
- ξ Heat detectors shall be of the fixed temperature (58° C) or rate of temperature rise type with a fixed temperature operating point.

- § Devices shall be compatible with the CIE conforming to the requirements of UL/ EN54 Part 5 the detectors shall have a single LED to indicate the device has operated and shall fit a common addressable base.
  - § All bases shall be compatible with the type of detector heads fitted and the control system component used. Each base shall comprise all necessary electronics including a short circuit isolator.
  - § The device shall be automatically addressed by the CIE on power up of the loop without the need of the insertion of a pre-programmed EPROM or setting of DIL switches.
  - § Detector bases shall fit onto an industry standard conduit box.
  - § Addressable Manual Call points must also be provided
  - § Control & Monitor module must be provided for integration with 3rd party systems.
29. **Audible Alarms** – Electronic sounders shall be colored red with adjustable sound outputs and at least 3 sound signals. The sounders should be suitable for operation with a 24V DC supply providing a sound output of at least 100dBA at 1 meter and 75 dBA min, for a bed head or sounder base type device. The sounder frequency shall be in the range of 500Hz to 1000Hz.
30. Commissioning
- § The fire detection and alarm system will be programmable and configurable via an alpha numeric keypad on the control panel.

### **1.1.4 Aspirating Smoke Detection System**

31. This specifications covers the requirements of design, supply of materials, installation, testing and commissioning of Aspirating Smoke Detection System. The system shall include all equipment's, appliances and labour necessary to install the system, complete with high sensitive LASER-based Smoke Detectors with aspirators connected to network of sampling pipes.
32. Codes and standards
- § The entire installation shall be installed to comply one or more of the following codes and standards
  - § NFPA Standards, US
  - § British Standards, BS 5839 part :1
33. Approvals
- § All the equipment's shall be tested, approved by any one or more:
  - § LPCB (Loss Prevention Certification Board), UK
  - § FM Approved for hazardous locations Class 1,Div 2
  - § UL (Underwriters Laboratories Inc.), U
  - § ULC (Underwriters Laboratories Canada), Canada
  - § Vds (Verband der Sachversicherer e.V), Germany
34. Design Requirements
- § The System shall consist of a high sensitive LASER-based smoke detector, aspirator, and filter.
  - § It shall have a display featuring LEDs and Reset/Isolate button. The system shall be configured by a programmer that is either integral to the system, portable or PC based.
  - § The system shall allow programming of:
- a) Multiple Smoke Threshold Alarm Levels.
  - b) Time Delays.
  - c) Faults including airflow, detector, power, filter block and network as well as an indication of the urgency of the fault.
  - d) Configurable relay outputs for remote indication of alarm and fault Conditions.
    - § It shall consist of an air sampling pipe network to transport air to the detection system, supported by calculations from a computer-based design modeling tool.



## Volume- II

- § Optional equipment may include intelligent remote displays and/or a high level interface with the building fire alarm system, or a dedicated System Management graphics package.
- § Shall provide very early smoke detection and provide multiple output levels corresponding to Alert, Action, Fire 1 & 2. These levels shall be programmable and shall be able to set sensitivities ranging from 0.025 – 20% obscuration / meter.

### 35. Displays on the Detector Assembly

- § The detector will be provided with LED indicators.
- § Each Detector shall provide the following features: Alert, Alarm, Fire 1 and Fire 2 corresponding to the alarm thresholds of the detector/Smoke Dial display represents the level of smoke present, Fault Indicator, Disabled indicator

### 36. Sampling Pipe

- § The pipe shall be identified as Aspirating Smoke Detector Pipe along its entire length at regular intervals not exceeding the manufacturer's recommendation or that of local codes and standards.

### 37. Installation

#### 38. The SI shall install the system in accordance with the manufacturer's recommendation.

- § Where false ceilings are available, the sampling pipe shall be installed above the ceiling, and Capillary Sampling Points shall be installed on the ceiling and connected by means of a capillary tube.
- § Air Sampling Piping network shall be laid as per the approved pipe layout. Pipe work calculations shall be submitted with the proposed pipe layout design for approval.
- § The bidder shall submit computer generated software calculations for design of aspirating pipe network, on award of the contract.

## 1.1.4 Access Control System

Make Offered:			
Model Offered:			
S. No.	Minimum Specification	Compliance Yes/No	Pg. No in Supporting Doc.
1	The Access Control System shall be deployed with the objective of allowing entry and exit to and from the premises to authorized personnel only. The system deployed shall be based on Biometric Technology. An access control system consisting of a central PC, intelligent controllers, power supplies and all associated accessories is required to make a fully operational on line access control system. Access control shall be provided for doors. These doors shall be provided with electric locks, and shall operate on fail-safe principle. The lock shall remain unlocked in the event of a fire alarm or in the event of a power failure. The fire alarm supplier shall make potential free contacts available for releasing the locks in a fire condition especially for staircase and main doors. Entry to the restricted area shall be by showing a proximity card near the reader and exit shall be using a push button installed in the secure area. The system shall monitor the status of the doors through magnetic reed contacts. The system should be designed and implemented to provide following functionality:		
2	Controlled Entries to defined access points		
3	Controlled exits from defined access points		
4	Controlled entries and exits for visitors		

Make Offered:			
Model Offered:			
S. No.	Minimum Specification	Compliance Yes/No	Pg. No in Supporting Doc.
5	Configurable system for user defined access policy for each access point		
6	Record, report and archive each and every activity (permission granted and / or rejected) for each access point.		
7	User defined reporting and log formats		
8	Fail safe operation in case of no-power condition and abnormal condition such as fire, theft, intrusion, loss of access control, etc.		
9	Day, Date, Time and duration based access rights should be user configurable for each access point and for each user.		
10	One user can have different policy / access rights for different access points		

Table 54: Specification for Access Control System

### 1.1.4 Customized Billing Solution- BSS

ξ **B2B-Enterprise Model** Operator offering the Enterprise services (VPN, MPLS, P2P etc.) to the Enterprise Customers. Service based, No. of Links/ dark fibre and Circuits based billing should be supported.

ξ **Wholesale Model** Wholesale operator leasing the network to various CSP/ISP/Cable Operators/OSPs. Leased Line, Bandwidth, QoS/CoS/SLA based billing should be supported.

¾ **Digital Customer Relationship Management (CRM)** Communication Service Providers (CSPs) with complete selling, marketing, monetization and self-care capabilities. With customer at the heart of offering, it offers a complete new way to interact and engage with CSPs – Customers and Partners, enabling them to monetize their services via every touch point, channel and device.

- a. **Enterprise (B2B)** Integrated partner management module to create combined offers/packages, using their core products with partner offerings. Digital CRM should support following:
  1. Organization/Unit/Channel Partner/Hierarchy creation: System should enable B2B organizations to accommodate a wide variety of distributors, resellers, retailers and stores on a single platform, while automating sales administration and maintaining the operational efficiency required to drive customer satisfaction and, ultimately, profits.
  2. Self-serve Organization Management: System should provide B2B customers with a self-service area to set up and manage their company. The B2B customer builds an Organization Structure to group their users who will interact with the B2B merchant in terms of permissions, rights and their hierarchy within the organization. It shall be flexible enough to allow for a wide range of company set ups from small and simple up to large and complex. The self-service area includes the following functions:
    - ξ Business units
    - ξ Order permissions
    - ξ Users and user groups
    - ξ Cost centres Budgets
    - ξ Order approval workflow
    - ξ Early login to allow organizations to set up visibility of catalogues for general purpose or logged in users.
    - ξ Registration form available for customers logging in for the first time.
  3. B2B Users and Access Groups: System shall allow to create various B2B users based on various different needs along with access rights

4. Persona and eKYC details: System shall allow to create the persona details for the B2B Users created for Unit/Channel Partner that would carry all important information like: Name, Address, Biometric Impression, Unique Identity number like Aadhar card etc.
5. B2B Spend Control: System should be able to support below
  - § Cost Centres and Budgets – shall be added to the organization to group and manage expenditure, and therefore reduce the B2B customer organization’s exposure to the B2B Operator
  - § Credit Limit – Shall enable to protect their interests the Operator's Account Managers can define Credit Limits for or within their B2B Customer Organizations. They can assign multiple credit limits with a variety of currency and date-range options to their B2B accounts. After an order has been placed the Account Manager will receive a credit limit alert if an order has exceeded the assigned limit. Orders will be processed up the point the credit limit is reached; after which they will be directed to a holding area from which they can be released by the Account Manager.
  - § Configurable Authorization and Workflows – Shall support highly configurable workflow rules and authorizations ensure complete control over budgets. Administrators can easily assign levels of access (or permission) to a specific person or role. They can create and modify rules that allow users to access customized catalogues, place orders within a given budget and/or approve orders. (See also Order Approval feature, below)
6. B2B Self-Service: System should support below
  - § In the online self-service area B2B customers shall be able to manage their quotes, track order history and use the order replenishment and scheduling capabilities.
  - § For B2B customers who are company approvers, there shall be easy access to managing order approvals.
7. B2B Customer Account Management: System should support below
  - § Self-service control over customer information such as delivery addresses, payment methods, and personal details from within the My Account area. Customers can manage details such as:
    - § Updating personal details.
    - § Updating account password.
    - § Editing / removing delivery address.
    - § Setting a default delivery address.
    - § Setting a default payment method.
    - § Viewing order history
  - § Manage Units/View Hierarchy (CP)
8. B2B Special Pricing: System should support below
  - § It shall support the various commerce accelerator for B2B examples special volume pricing with tool-tips appearing on products with volume pricing setup.
  - § Digital CRM shall support other forms of special pricing such as customer, customer group specific pricing and product (or product group) specific pricing which can be configured.
9. B2B Multidimensional Products: System should allow to define multidimensional products using multiple attributes i.e. Colour, Model etc.
10. B2B Advanced Search: System should allow advanced search option that shall allow users to search for products using default string search or by their product IDs. After the search result is presented, user may select multiple products which will later on be available in the order form for mass purchases.
11. B2B Purchase Order Form Generation: System should allow
  - § Should support advanced search functionality together with multidimensional products attributes that shall enable customers to create mass orders in an easy and efficient way. For each of the products in the search lists that were added to the order form, system should create a grid list that displays all available dimensions of all products together with their stock availability.
  - § Should support creation of orders that contain multiple products (dimensional and non-dimensional items)
  - § Should support future availability of a product

- § Should be available in both Product Details and Checkout view
- 12. B2B Online Ordering & Order Replenishment: System should allow users to place orders online and schedule orders that are automatically replenished. It should also support the below
  - § Order Replenishment - B2B customers can better manage routine ordering by using the automated stock replenishment capability.
  - § Re-Order -The same selection of products can be ordered based on a previous order.
- 13. B2B Order Management: System should allow that all order management functions are easily accessible from B2B Portal, from where B2B customers should have ability to view their:
  - § Order history details
  - § Order status details like Quantity approved, Order approved, rejected
  - § To manage their replenishment schedules or set up a new replenishment schedule
- 14. Partial order fulfillment: System should facilitate partial fulfillment of orders in case of insufficient stock. B2B user should be able to check this partially accepted order status from order History, and shall be able to have details available such as available quantity & reserved end date for that order. Accept & Reject button should be available against the order and B2B user should be able to either accept the order with partial quantity or reject the whole order.
- 15. Hold Orders: In case of insufficient stock, a B2B user(distributor) should be able to put an order (coming from down line) on hold. In turn, B2B user should be able to raise an order to its parent unit.
- 16. B2B Order Approval: System should support order approval, that should enable the manual validation and approval of orders placed by a B2B customer both on the customer and on the operator side. The key components of this process should include following:
  - § B2B Customers should have specific ordering permissions such as a monetary threshold per order. e.g. the order is less than the threshold, the order is automatically approved. If the order exceeds the permission, the order is placed in a pending approval state. Eligible order approvers are notified and must manually approve or reject the order.
  - § Order Thresholds can be defined on a per-order basis, or cover a time span of weeks or months. An optional permission to exceed the assigned budget can be given to specific B2B customers.
  - § To provide customer approval for an order a user must have the B2B Approver role. In addition, he must also have rights which define the monetary limits to which he can approve. The position of the B2B Approver in the hierarchy is used by the Customer Approval Process when finding the least senior B2B Approver permitted to approve an order.
  - § If the order exceeds the B2B unit's credit limit on the merchant's side it requires additional approval by the assigned Account Manager in the Digital CRM business tools.
  - § To view, approve and reject pending orders, the B2B Approver should be able to use the Order Approval Dashboard.
  - § Features like Hold order, Approve/Reject partial orders, Cancel Order should be available.
- 17. Easy Returns: System should allow to request a complete or partial return using B2B storefront. This should allow to bypass having to call a customer service agent to return an order that was placed. It should also support requesting a partial return for an order or request a complete return for an order.
- 18. B2B Assisted Service Module: System should enable customer service personnel to provide real-time customer sales and service support, using the same storefront across the Omni-channel framework, both physically shoulder-to-shoulder, in-store, and virtually online.
- 19. Checkout Privileges Respected: System should enable not to override checkout restrictions that apply to the customer. If an agent tries to check out with a user that is not allowed to do so (for example, the customer is an administrator and not a B2B customer), the message, "your account does not allow you to checkout" here is displayed.
- 20. My Company Pages: System should allow customer service personnel to access the B2B Portal - My Company pages on behalf of the B2B Commerce Administrator. The customer service personnel shall only be able to access My Company if they have the administrative privilege.

21. Advanced Configurations: System should also allow to configure for more advanced scenarios, such as setting promotions that only an agent can apply to a customer's cart, or create a special product category that is only viewable by agents.
22. Partner Credit Balance: System should allow to associate Credit Balance with Channel Partner(CP). CP should purchase credit balance through online payment. Credit Balance should also be augmented via commission earned by CP. The Credit balance is used by CP to perform operations like Recharge, Subscriptions, B2B Order fulfillment. CP should be able to view the commissions earned in B2B portal
23. Quick Communication: System should allow operators to send Email notifications automatically to confirm/cancel orders, tickets or in responses to interactions.
24. 2-way Ticketing: System should allow each unit to have 2-way ticket visibility mechanism. Units can raise their tickets from B2B portal & can view from portal itself. Units can see tickets raised to them by their downline in back office.
25. Integration with PBSS: Digital CRM (B2B) should be integrated with PBSS (Partner BSS aka Partner Management). The Channel Partner billing, commissions and pay-outs should be triggered in PBSS system
26. Mobile APP for Partner: System should support following for Partner APP
  - ξ View & Update Personal Data: View and update personal details associated with the partners
  - ξ View Commission: View commission details
  - ξ View credit limit assigned by MSO

### <sup>3</sup>/<sub>4</sub> **Billing System**

The Billing System should support Enterprise & Wholesale Billing with following functionalities:

#### **a. Product Management/ Product Catalogue**

1. Product Life Cycle Management (PLM): Product lifecycle should define the lifespan of the individual product from concept to retirement. Each entity in PLM shall have a different lifecycle of its own.
2. Product Offer / Product Package Management: The system must provide a bottom-to-top approach for creating product packages. The component model shall allow OPERATOR to re-use existing components for speedy launches. Further, the system shall enable the operator to edit/update these entities as per the business requirement.
3. Capability to offer variety of plans: Ability to leverage Product Management features to quickly and easily develop & implement new pricing plans. It shall offer wide range pricing plans for Convergent services - Volume-based Data Plans, Volume-based Data with over-usage policies, Time-based (Happy Hour) Plans, Value-based Data Plans
4. Service Hierarchy Definition: Ability to provide Service Specification module that allows creating services and sub-services with a support to create n-level of hierarchy of services.
5. Service Level Convergence: The system should provide the convergent platform by supporting prepaid and post-paid convergence, multi-service, multi-technology convergence. It should support multiple business models viz. wholesale & enterprise. It should have the ability to rate and bill usage of multiple services.
6. Product Offer Types: System should allow creating variety of tariff plans
  - ξ Basic Plan consisting of the product specification, base tariff details and the free usage details in the plan
  - ξ Add-on Plan an offer over and above the basic plan in the customer account to give additional perks such as a rate cutter, bandwidth on demand, special tariffs/offers etc
7. Discount Scope: System should provide with Discount Scope. The scope defines the visibility/availability of discount. (How discount will apply)
  - ξ Package level Scope - The discounts are bound to the plans, to which these are to be applied
  - ξ Global level Scope - The discounts if not bound to any plan, will be Global i.e. applied to all.
8. Product Manager should offer the flexibility to customize the configuration screens for various entities – Rate Card, Usage Parameter Group, etc. as per OPERATOR's requirement. This will allow

OPERATOR to decide as to what features are to be made visible on the screen at the time of configuring a specific entity. OPERATOR can restrict the availability of certain features as per requirement.

### b. **Billing Functional Requirements**

1. **Bill Cycle Management:** System should support Bill Cycle Management. A CSR assigns a bill cycle to the customer account at the time of account creation. A bill cycle is the period for which the BE generates bills for the set of customers that belong to the particular bill cycle.
2. **Invoice Types:** The Billing system should support below type of invoices:
  - ξ Sales Invoice - Sales Invoices are generated for the below event/process:
    - o When service instance is activated from registered state with billing effect as 'immediate', a sales invoice for advance charges is generated.
    - o A manual invoice (of type sales invoice) can be generated for the existing or non-existing/walk-in customers.
  - ξ Regular Invoice - Regular invoices are cyclic invoices that are generated at the end of billing cycles defined for the customer. Bill Generation Agent is used to generate regular invoices for customers.
  - ξ On-demand Invoice - The on-demand invoice is generated when the customer requests for the invoice in the middle of billing cycle. The On-demand invoice cannot be generated for the future date. This invoice consists of arrears charges and usage till date.
3. **Bill Rules Management:** System should support Bill Rule Management. A Bill Rule Configuration is a technical framework which enables the system to comply with changing business requirements. Bill Rules can be used to define certain criteria based on which the billing will be done.
4. **Customized Bill Templates:** System should support Bill template (JRXML/XSLT) management. Bill template management will be used to define Invoice templates to generate formatted bills. The file types can be text or PDF.
5. **Tax Application:** System should support the following:
  - ξ Tax Application configuration allows you to apply tax globally or based on some attributes. The tax amount can be configured as either of the following:
    - o Inclusive – The tax amount is included in the charge amount
    - o Exclusive – The tax is applied exclusively on the charge amount
6. **Split Bills Functionality:** System should allow the service provider to configure aksplit charge refers to customized allocation of charges across two billing accounts as per the subscriber's requirement. The following charges can be split:
  - ξ Non-Usage Charges – The rentals and other recurring charges can be split across the billing accounts in absolute or percentage value of the total amount.
  - ξ Usage Charges – The usage charges can be split using the following:
    - o Time band split – The usage done in the specific time duration of the day can be split, the rest borne by the owner.
    - o Absolute or Percentage – The usage charge can be split across the billing accounts in absolute or percentage value of the total amount
7. **Backdated Billing:** System should support backdated billing. Backdated Billing is used to bill accounts, services, product and discounts to a prior date. Backdated billing is used to charge customers for previous dates.
8. **Trial Bill Generation:** System should support Trial Bill functionality. The Trial Bill Run should allow OPERATOR to validate the accuracy of the bills before actually generating bills for the customers.
9. **Bill Delivery Modes:** System should support sending paper copy or electronic copy of bills to the customers. Required delivery mode for the bill can be selected when the customer account is being created in the system.
10. **Bill Download Formats:** Should allow operator to download an invoice in different formats like – PDF, CSV, XLS, TXT, POSTSCRIPT, HTML and FLATFILE. One can download both trial bill and the actual bill.



11. Bill Disputes Handling: System should allow the service provider to manage the bill disputes raised by the subscribers. It should allow marking the subscriber's bill or a particular bill charge as 'Disputed' or 'Undisputed' with reasons. A dispute can be raised on the following:
  - § Bill – In this case, the dispute is raised on the total bill amount
  - § Bill Charge – In this case, the dispute can be raised on a particular charge that is erroneous.
12. Cancel Bill: System should support Cancel bill feature to allow service provider to cancel the existing invoice and reproduce new invoice with correction.
13. Re-Generate Bill: System should support Re-Generate Bill functionality to allow service provider to generate the cancelled invoice again after correction.
14. Generate aggregated statement: System should support generation of aggregated statement. Billing Aggregator is an entity that has multiple billing accounts mapped under it. It will serve as a grouping entity of all billing accounts mapped to the single billing aggregator.
15. Types of Services:
  - a. L2 & L3 VPN
  - b. Fibre leasing
  - c. Internet Bandwidth
16. Customer Types:
  - a. CABLE MSO providers
  - b. Telco Service Provider / Internet Service Provider
  - c. Government Offices/Setup (Horizontal Connectivity)
  - d. Private B2B Customers (Banks etc)
17. Tariff shall include leasing partner's agreement, but not limited to:
  - a. Unit (monthly, quarterly, yearly).
  - b. Fixed charges
  - c. Maintenance charges
  - d. Bandwidth offered (as per the Contract with the fibre Leasing Agency)
  - e. Length of Fibre
  - f. SLA based events
  - g. Quality of Service based
  - h. Class of Service based

### c. **Payments & Adjustments**

1. Payment Channels: System should provide with the following payment modes through which billing accounts (subscribers) can make payments:
  - § Online Payment Mode – Online payment mode refers to the payment modes through which payment is realized promptly. It includes: Cash, Credit Card, Debit Card, Online, and Demand Draft.
  - § Offline Payment Mode – Offline payment mode refers to the payment modes that require any third party involvement for realizing payments. It includes: Direct Debit and Cheque
2. Payment Priority: System should provide the support for defining payment priority. When a partial payment is made, the payment priority settings done by the operator are used to determine which elements of the bill are to be treated as paid and which to be treated as partially paid or unpaid.
3. Third Party Payment Gateways/Institutes: System should allow operator to configure the third party institutes such as Banks (Cheque, Direct Debit) and Payment Gateways (Online Payment).
4. Customized Payment Receipt Format: System should support configurable format of the payment receipt to have desired look & feel and contents in the receipt. Payment Receipt Templates should be configured for Original Payment Slips as well as Duplicate Payment Slips.
5. Payment Agreements: The system should allow configuring Payment plans to offer payment flexibility to the subscribers. Two types of payment plans can be configured:
  - § Budget Payment Plan - This payment plan can be used to configure the Auto Deduction payment method for the subscriber accounts
  - § Instalment Payment Plan - Instalment Payment Plan can be associated with a billing account so that the subscriber can make payment for pending debits/invoices in instalments.
6. Payment Types: System should support following payment types;

- § Debit Payment – This payment type refers to the payment against a debit document or an invoice. The system allows making payments in full, itemized, or partial amounts for all debit documents or for only the selected debit document(s) in a selected account.
  - § Advance Payment – This feature allows you to make advance payments for an account. Such payments are used to offset debits through auto-adjustment.
7. Transfer Payment: System should support a feature where the unadjusted amount in a subscriber's billing account can be transferred to another subscriber's billing account.
  8. Defer Payment: System should support a feature that allows the operator to defer a payment date to a prior or a previous date. A payment is deferred in cases where you do not want a subscriber to incur late payment charge (LPC).
  9. Write-off Bills: The system should allow fully or partially waiving off the outstanding amounts for a scenario like bad debt recovery.

### **d. Dunning:**

1. Dunning types: System should Support dunning both at the invoice-level and account-level:
  - § Invoice-level Dunning – In invoice-level dunning the receivables are chased on an invoice by invoice basis.
  - § Account-level Dunning – In account-level dunning all overdue amounts for an account, across several invoices, are handled by a single dunning action.
2. Dunning Notification Management: System should allow configuring the following Notifications related to Dunning:
  - § Dunning Notification Action (Communication to Subscriber)
  - § Dunning Unit Activity (Communication to Internal Staff)
  - § Dunning Escalation (Communication to Action Administrator)
  - § Collection Agency
3. Business Rule Management: System should allow Dunning to creating Business Rules. These rules are created to achieve business cases which are subject to change as per operator's policy or government regulations.
4. Credit Class: System should allow defining the credit class for a subscriber. The credit class defines a category of the subscriber and associated risk of revenue can be taken with that subscriber. A credit class also defines which dunning scenario is to be applied to the subscriber.
5. Dunning Actions: System should support Dunning Action Management. Dunning Action Management contains a set of actions which forms part of dunning scenario and vary in their applicability as per the configuration of scenario.
  - § Soft Dunning Actions (Dunning Notices)
  - § Hard Dunning Actions (Blacklisting)
6. Reverting Dunning Action: System should provide a feature to revert the dunning actions performed on an account. It might be required in a scenario where a customer is blacklisted and once the unpaid debts are cleared, subscriber must be white-listed.

### **e. Staff & Access Management:**

1. Access Control List: System should provide with the support of access rights, based on the user's role. It provides function for associating users with configurable roles that define which areas of functionality and data within the system, the user is allowed to access, and what transaction limits are imposed on the user.
2. Access Groups: System should provide with the support of access groups to define the rights that a group of users should have, based on the functions that are required to perform respective duties.
3. Staff Creation Modes: The system shall support the following modes for staff creation. The administrator can create staff accounts through either of the following two modes:
  - § Create Staff: By specifying all details such as login details, personal details, contact details, and adjustment details
  - § Create Quick Staff: To create staff instantly by entering only essential details
  - § Staff accounts can be searched, viewed, edited or deleted any time



- ξ Staff Management Activities: System should provides following functionalities to manage the staff account: Update Staff, Update Billing Area, Update Access Group, Change Status, Change Username, Change Password etc
- 4. Audit Trail: System should provide the Audit Trail functionality. Audit Trail keeps track of who did what, to what, and when they did it, as well as who tried to do something but was unsuccessful.
- 5. Event Notifications for staff activities: System should allow to configure notifications for the following events - Create Staff, Update Staff, Change Staff Password, Change Staff Status, Change Staff Username, Forgot Staff Password
- 6. Alerts and Reminder Management: The system should allow sending alerts and reminders to concerned user when any configured/required activity is performed. To send alerts first the alerts need to be configured in System alerts and reminder management.

### <sup>3</sup>/<sub>4</sub> **Web Self Care Module**

1. Web self-care module shall be able to provide a one-stop facility to the corporate customers (enterprise wide access – corporate self-care) with secure access to their information including but not limited to Bill viewing, Bill payment, complaint booking & monitoring, purchasing products & services online, updating personal information, general enquiry etc. using a standard Internet browser.
2. The main components of the Web Self Care Portal Framework which are available on 365x24 basis
3. Delivery Channels: Corporate Customers (enterprise wide access – corporate self-care), customers / dealers, Field Users, Regional Users Citizens and other Agencies. System shall support all types of customers / dealers including corporate customers.
4. Presentation Services: Application Services, Marketing Requirements Notification Services, Searching and Personalization, Online help
5. Business Support Services: Custom Applications, Electronic Bill presentment and payment, Processing Services and Reporting / Report Generation
6. Identity and Integration Services: Account and Service Management Features, Identity Management, Authentication and Authorization, System Messaging, Trouble Ticketing
7. Infrastructure Services: System Maintenance, System Management Integration web self-care module with the CRM, Billing, etc and other third party system (e.g. NMS, GIS etc). The portal framework supports content delivery to a number of different devices.
8. Web Portal: The web portal would provide information as well as links to delivery services for the main actors in the system.
9. Payment Gateway Integration: The solution would support Payment Gateway and also support the integration with the KFON and all System Users through the web portal.
10. SMS Gateway Integration: The solution would support SMS based services and also support the integration with the KFON and all System Users through the web portal.
11. Email Integration: The solution would support email based services and also support the integration with the KFON and all System Users

### <sup>3</sup>/<sub>4</sub> **MIS, Reports and Analytics System**

1. KFON will have multiple applications in their IT environment, applications such as Customer relationship management (CRM), Billing System, Order management and provisioning application, etc.
2. The centralized enterprise reporting system shall have visibility and access capability to take data from all the mentioned applications and will create reports and analytics to be used for various reporting purposes by KFON.
3. System should have the capabilities to present reports in a dash-board like environment for the top management so as to help them make intelligent decisions based on factual data.
4. System should have capability to use Data Centre (DC) environment by using production/archived data for report generation. The reporting requirement is primarily two types:
  - ξ Mandatory Reports (Standard): Needed by KFON Management, TRAI, CCI, DOT and other government agencies.)
  - ξ Customised Reports: Needed by KFON on Daily, Weekly, Quarterly and Yearly Basis for various Activities:
    - ξ CRM

- § Billing
  - § Payments
  - § Service Activation and Assurance
  - § Trouble Tickets
  - § Contact Centre Activities
  - § Batch Mode replication of Data
5. The System should take care of the enterprise wide reporting need for KFON and should have the components for creating comprehensive reports.
  6. SI must have capability to support additional Reporting and Analytics requirements during implementation and contract period as per KFON business needs.
  7. The specifications listed below layout requirements of a platform required for reporting needs of KFON middle level & top management for this project.
    - § The users shall be able to login and access the reporting platform based on their privileges.
    - § MRAS must have web based interfaces
    - § Able to pull and analyze data from multiple data sources in Data Center.
    - § Ability to drill, slice, dice. The level of drill, etc. shall be finalized in the SRS Phase.
    - § Ability to create graphs, charts on parameters mentioned in Reports
    - § Ability to download reports for KFON Management users depending on access privileges
    - § Must provide online Help and Tutorial feature to get the desired outputs
    - § MRAS Management of Users, Folders, Servers, Objects, User Groups, Server Groups, Authorization and Setting
    - § Each user shall be able to get scheduled reports on his/her chosen e-mail ID. e.g: Various report type
    - § Ad Hoc Reports
    - § Object and Folder level Security
    - § Multiple Export format support including PDF, MS XL, MS Word, RTF and HTML
    - § Objective model programmable administrative control mechanism
    - § Parameterized reporting and sorting
    - § Cross Platform Deployment
  8. The report design software shall have following features:
    - § Multiple report types including Mailing Labels, Cross Tabs, Conditional and other reports
    - § Local printing and exporting capability
    - § Formula expert, customs functions and display string formatting
    - § Unlimited SQL commands
    - § Capability error-check queries in the reporting software. Policies in this regard shall be user configurable by the administrator.

<sup>3</sup>/<sub>4</sub> **Monitoring Tool** monitoring tool shall monitor following parameters:

1. Hardware and Software Application modules of at NOC.
2. The management system shall alarm critical, major and minor events.
  - § The Management System shall display alarms based on violation of traffic thresholds of each of the interfaces, interconnection links with other nodes and system performance indicators (KPI). It shall be possible to customize these KPIs. Display alarms based on thresholds violation system parameters such as: size of files systems, processor load, memory utilization etc.
3. All kind of reporting about system's capacity & licensing utilization. Reporting about connected/concurrent users; Reporting about connected users & their status with time duration.
4. Monitor performance and faults. Support for event notifications. Support of SNMP protocol standard. Support full backup and restoration of the system configuration, system database, reports, configuration profiles, views, maps, Concurrent number of transactions/second etc.
5. Login and session details, browsing history and audit trails. The solution shall provide at least the following statistics. Number of login attempts; Number of successful sessions; Number of failed sessions.

<sup>3</sup>/<sub>4</sub> **Order Management** Order Management System shall manage and orchestrate different type of order/request related to other systems namely CRM, Billing etc. The OM system shall enable the complete business flow for order entry / replacement and fulfilment:

1. The system shall include an integrated order entry process for various types of products, places of installation, geographic area and clients, temporary product. CRM should ensure all necessary information about the Customer Order (for example, type of product, address, payment information, special requirements, etc.) is available.
2. This functional area must be able to receive service requests from the Order Entry system. This process behaves as an entry point for service requests into the application and notifies the Order Management functional area of new or changed service requests. Order Entry shall be able to receive different types of orders e.g. installation, fault, maintenance etc.
3. Multi-channel - The Order Entry process shall be prepared to receive order feeds from a number of different channels, such as Customer Care applications, back-end offices, POS, third party dealers, Internet, extranet, intranet, IVR- etc.
4. The Order Entry process shall be integrated with the CRM, billing etc.
5. Order priority - Ability for the service representative to assign and display a priority level, indicating the level of care that needs to be given to the order
6. Billing accounts information - Ability to capture billing account and billing information required to bill the product or service.
7. Order identification - The system shall generate a unique internal order ID. It shall also be able to reference an internal order ID with several external order IDs.
8. Provide information with order status - Provide CSRs or other entities with information regarding the order status.
9. Order tracking - Ability to track all information within an order at all task levels; Ability to monitor orders by different types of information, which may be geographical information, order type, resources allocated, etc.
10. View orders/requests rejected by downstream systems - Ability to view order status based on rejections by downstream systems (e.g. Billing, CRM).
11. Managing multiple order amendment - Ability to recycle in batch multiple orders after correction for a particular rejection; with this functionality, OM is able to correct all the orders for which the same rejection occurred (e.g., product-related rejections).
12. Interface with provisioning platforms: Workflow engine shall have to interface with the provisioning platforms following the order, thus installing the necessary features and line classes, modifying them or taking them away. Also, it shall be possible to interface both online and through batch processes
13. Re-routing of orders - Ability to re-route the order or create an alternative workflow based on information of up- and downstream systems.
14. Escalation of orders - Mechanism based on a set of business rules to escalate orders in terms of workgroups, priority etc.
15. Support of order life-cycle in differing transition states - Ability to flag the order to the appropriate office for manual intervention (e.g., incomplete information).
16. The system should have the ability to define the type of fulfilment required for a particular order. These types of fulfilment shall be determined according to business rules which include all the functionality associated with service provisioning, inventory management and work force management, necessary to complete the order.
17. The system should have the capability to break down an order into different parts and fulfil the parts separately at different times. This can be linked to the provisioning timing or to the customer's demands.
18. The system should have the capability to automatically recognize that the entire work has been done and that the order can be closed and moved to order history.
19. It should allow cancellation of customer order. Order cancellation request may come from Portal/CRM. Penalty for cancellation will be as per pre-configured rules. CRM should inform customer regarding cancellation penalty (if applicable).
20. Reports – The system should be able to generate various management and analysis reports such as Total number of orders, Number of orders per input source, per entity and per user etc.

## Volume- II

---

Total number of subscribers	
Number of concurrent subscribers	
Number of users for WSC Portal	
Number of CRM Users	

## 1.2. Passive Components

### 1.2.1. General Requirements for Optical fibre

- § All optical fibre cabling including fibre itself and all associated installation hardware shall have a minimum guaranteed design life span of 25 years. Documentary evidence in support of guaranteed life span of the same shall be submitted during the Bid.
- § Details of route along with its estimated length are provided as part of this tender. Any other details, as required for cable design etc. shall be collected by the SI during survey.
- § The SI shall supply & install the optical fibre cable as required based on detailed site survey to be carried out by the SI during the project execution. The Contract price shall be adjusted accordingly.
- § For the purpose of payment, the optical fibre link length is defined as route length from one terminating point to another. The actual cable lengths to be delivered shall take into account various factors such as sag, service loops, splicing, working lengths & wastage etc. and no additional payment shall be payable in this regard.  
**The unit rate of OF cable and accessories quoted in the Bid price schedules shall take such factors.**
- § Dimensions, weight and composition of the material used for each accessory shall be specified by the manufacturer, wherever applicable
- § All insulating plastic/rubber shall be UV resistant
- § Bidder shall furnish complete technical details and test reports along with the Bid.
- § All the tender items e.g. OFC, Patchcords, FTB, BJC, FDMS, Splitters should have valid Type Approval Certificate (TAC) from Telecom Engineering Centre (TEC), New Delhi or Technical Specification Evaluation Certificate (TSEC) from Quality Assurance Circle, BSNL, Bengaluru, against the respective technical specifications of this RFP (wherever asked for). In case any of the quoted models does not have TAC/ TSEC then it should be applied for TSEC to Quality Assurance Circle, BSNL, Bengaluru or to TEC, New Delhi for the model against the technical specifications, at least one day before the bid submission date. The registration number allotted for the TSEC purpose by Quality Assurance Circle, BSNL, Bengaluru or for TAC purpose by TEC, New Delhi shall be submitted along with the bid. However, only type approved products as per specifications shall be accepted which shall have to be obtained before issuing Work Order by the Tenderer. The approval shall not be older than two(2) years from the date of submission of bid
- § Type test reports for OPGW shall not be older than five(5) years from the date of submission of Bid and should have been conducted at any of the laboratory approved by Government of India/International Laboratory Accreditation Cooperation(ILAC)/ NABL accredited Labs
- § Technical (installation and maintenance) manual (in English language) with diagrams and complete details (model no., material, dimensions, weight, manufacturer, etc.) shall be provided by the SI in both soft copy and hard copy
- § Bidder shall provide data requirement sheets duly filled and submitted along with Technical Bid. (Use additional sheets if required)
- § Bidder shall have necessary test equipment like OTDR, LSPM for conducting Acceptance Tests and will also make available the same to Authority and its designated agencies for conducting the tests. All test equipment shall have valid calibration certifications and shall produce the same at the requests of the Authority.
- § The SI shall demonstrate a specified level of performance of the offered fibre optic links during well-structured factory tests and field tests.

### 1.2.2. Technical Specifications for Single Mode Optical Fibre

Single Mode Optical Fibre used in manufacturing optical fibre cables (ADSS/Underground/OPGW Cables) shall be as per ITU-T Rec. G 652.D. The specifications of optical fibres are mentioned below

SL No.	Parameter	Minimum Specification
1.	Optical Fibre	ITU – T G.652.D

## Volume- II

SL No.	Parameter	Minimum Specification
2.	Type of fibre	Single mode (Section I (Type III) of TEC GR No: TEC/GR/TX/ORM-01/04/SEP-09 and subsequent amendments, if any)
<b>Geometrical Characteristics</b>		
3.	Mode Field Diameter at 1310 nm	8.8 to 9.8 $\mu\text{m}$
4.	Cladding Diameter	125.0 $\mu\text{m} \pm 1.0 \mu\text{m}$
5.	Cladding non-circularity	$\leq 1\%$
6.	Core Clad concentricity error	$\leq 0.6\mu\text{m}$
7.	Diameter Over Primary Coated with double UV cured acrylate (shall be measured on un-coloured fibre)	245 $\pm 10 \mu\text{m}$ <i>Thickness of the coating may be over and above the values specified above if manufacturer adopts separate UV colouring process (to colour the un-coloured fibres) other than the on-line integrated colouring process (of secondary layer of primary coating) of the fibres, during fibre manufacturing</i>
8.	Coating/Cladding Concentricity	$\leq 12 \mu\text{m}$
<b>Transmission Characteristics</b>		
9.	Fibre Attenuation before Cabling	@ 1310 nm : $\leq 0.34 \text{ dB/km}$ Between 1285 and 1380 nm : $\leq 0.37 \text{ dB/km}$ Between 1390 and 1525 nm : $\leq$ Value at 1310 nm @ 1550 nm : $\leq 0.21 \text{ dB/km}$ Between 1525 and 1625 nm : $\leq 0.24 \text{ dB/km}$
10.	Water Peak Attenuation before Cabling	Between 1380 and 1390 nm : $\leq$ Value at 1310 nm
11.	Fibre Attenuation After Cabling	@ 1310 nm : $\leq 0.36 \text{ dB/km}$ @ 1550 nm : $\leq 0.23 \text{ dB/km}$ @ 1625 nm : $\leq 0.26 \text{ dB/km}$
12.	Water Peak Attenuation After Cabling	@ 1383 nm $\pm 3\text{nm}$ : $\leq$ Value at 1310nm
<b>Dispersion</b>		
13.	Total Dispersion	In 1285-1330 nm band: $\leq 3.5 \text{ ps}/(\text{nm} \times \text{km})$ In 1270-1340 nm band: $\leq 5.3 \text{ ps}/(\text{nm} \times \text{km})$ @1550 nm : $\leq 18 \text{ ps}/(\text{nm} \times \text{km})$ @1625 nm : $\leq 22 \text{ ps}/(\text{nm} \times \text{km})$ <i>The total dispersion in the 1250-1625nm band shall be measured at an interval of 10nm and the test results shall be submitted.</i>
14.	Polarization Mode Dispersion at 1310nm & 1550 nm	Fibre: $\leq 0.2 \text{ ps}/\sqrt{\text{Km}}$ Cabled Fibre: $\leq 0.3 \text{ ps}/\sqrt{\text{Km}}$ <i>Measurement on un-cabled fibre may be used to generate cabled fibre statistics and correlation is established.</i>

**Volume- II**

SL No.	Parameter	Minimum Specification
15.	Zero Dispersion Wavelength	1300 to 1324 nm
16.	Zero Dispersion Slope	$\leq 0.092$ ps/(nm <sup>2</sup> x km)
17.	Cable Cut-off Wavelength for fibres used in cable	1320 nm Max <i>The above cut-off wavelength is wrt 2M sample length of fibre</i>
18.	Cable Cut-off Wavelength	1260 nm Max <i>The above cut-off wavelength is wrt 22M sample length of fibre</i>
<b>Mechanical Characteristics</b>		
19.	Proof Test for minimum strain level (Test method IEC 60793-1-30)	1%
20.	Peak Stripability force to remove primary coating of the fibre (Test Method IEC 60793-1-32)	$1.3 \leq F \leq 8.9$ N
21.	Dynamic Tensile Strength (Test Method IEC 60793-1-31)	$\geq 550$ KPSI (3.80 GPa) for Un-aged $\geq 440$ KPSI (3.00 GPa) for Aged
22.	Dynamic Fatigue (Test Method IEC 60793-1-33)	$\geq 20$
23.	Static Fatigue (Test Method IEC 60793-1-33)	$\geq 20$
24.	Fibre Micro Bend (Test Method FOTP- 62/IEC 60793-1-47)	
A	Change in attenuation when fibre is coiled with 100 turns on $30 \pm 1.0$ mm diameter mandrel	$\delta$ 0.05 dB at 1550nm $\delta$ 0.5 dB at 1625nm
B	Change in attenuation when fibre is coiled with 1 turn around $32 \pm 0.5$ mm radius mandrel	$\delta$ 0.5 dB at 1550nm $\delta$ 1.0 dB at 1625nm
25.	Fibre Curl (Test Method IEC 60793-1-34)	$\geq 4$ meter radius of curvature
<b>Environment Characteristics</b>		
26.	Operating Temperature (Test Method IEC 60793-1-52) Temperature Dependence of Attenuation: Induced Attenuation at 1550 nm at -60 °C to +85 °C:	-60 °C to +85 °C $\leq 0.05$ dB/km
27.	Temperature – Humidity Cycling (Test Method EIA/TIA-455-73) Induced Attenuation at 1550 nm at -10 °C to +85 °C	$\leq 0.05$ dB/km and 95% relative humidity
28.	Water Immersion 23 °C (Test Method IEC 60793-1-53) Induced Attenuation at 1550 nm due to Water Immersion at $23 \pm 2$ °C	$\leq 0.05$ dB/km
29.	Accelerated Aging (Temperature) 85°C (Test Method IEC 60793-1-51) Induced Attenuation at 1550 nm due to Temperature Aging at $85 \pm 2$ °C	$\leq 0.05$ dB/km
30.	Retention of Coating Colour (Test method IEC- 60793-1-51) Coated Fibre shall show no discernible change in color when aged for relative humidity	30 days at 85°C with 95° Humidity and then 20 days in 85°C dry heat

*Table 55: Technical Specifications for Single Mode Fibre*

**Note:**



## Volume- II

1. Attenuation in the band 1380-1390 nm shall be checked at every 2nm after Hydrogen ageing as per IEC 60793-2-50. Hydrogen ageing test is to be carried out by CACT, Bangalore or any other recognized laboratory for type test.
2. Sudden irregularity in attenuation shall be less than 0.1 dB
3. The spectral attenuation shall be measured on un-cabled fibre.
4. The Spectral attenuation in the 1250 nm–1625 nm band shall be measured at an interval of 10nm and the test results shall be submitted.

### 1.2.3 Aerial ADSS OF Cable (48/24/12F) & Associated Hardware & Fittings

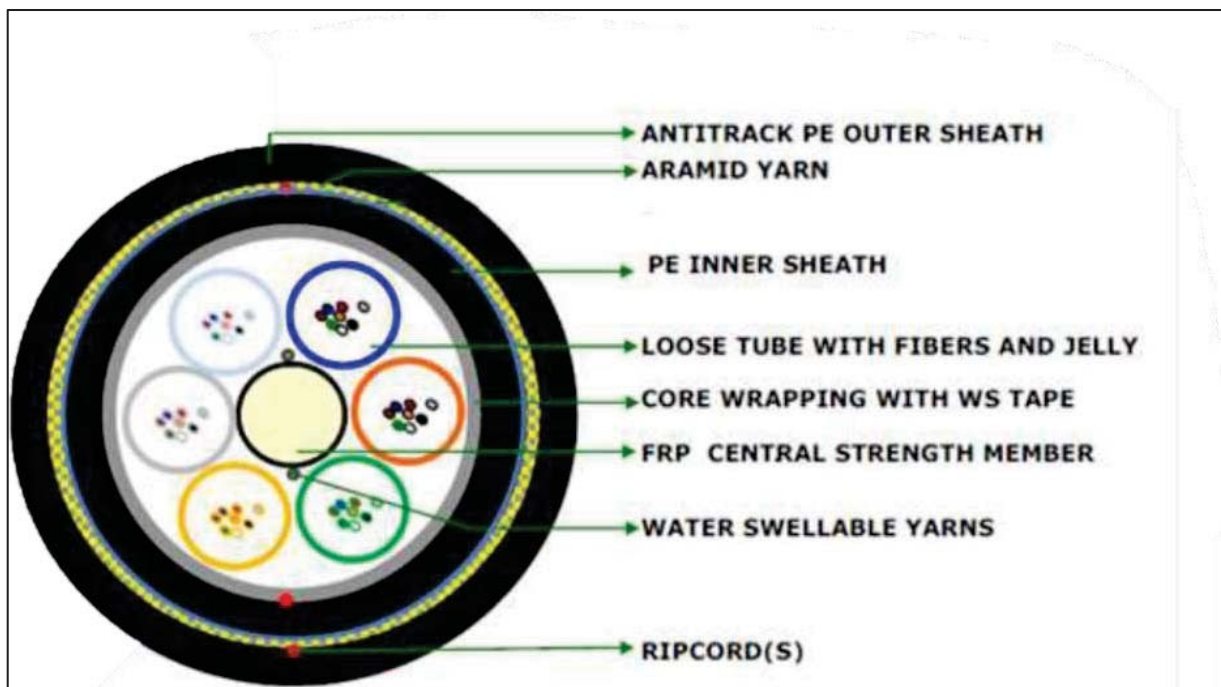


Figure 2: Typical ADSS OFC Construction Diagram

The following parameters of the cable are to be taken into account while designing and manufacturing the optical fibre cables of the required fibre count. These parameters shall be checked during evaluation of OFC. Manufacturer shall submit design calculations which shall be cross checked.

SL No.	Parameter	Minimum Specifications
1.	TEC Compliant	<p>TEC/GR/TX/OFC-022/02/MAR-17 Type II-A with latest amendments if any (for cable with 100 Kmph wind speed)</p> <p>For cable with 150 Kmph wind speed Bidder shall submit detailed compliance sheet for all the parameters asked for and all the tests should have been conducted at any of the laboratory approved by Government of India/International Laboratory Accreditation Cooperation(ILAC)/ NABL accredited Labs</p> <p>Anti-track PE material to be used for this product shall comply as per TEC GR No: TEC/GR/TX/ORM-01/04/SEP-09 with amendment issued on 28.03.2013.</p>
<b>Installation and Operation Condition</b>		



## Volume- II

SL No.	Parameter	Minimum Specifications	
2.	Max Span length	100m	
3.	Max Ice loading	Nil	
4.	Operational Wind Velocity	100 Kmph and 150 Kmph	
5.	Sag of span length	§ Max sag allowed without excess load: 1% of span length § Max sag allowed with excess load: 2% of span length	
6.	Temperature Range	§ Operation: -40 to +70 degrees C	
<b>OFC Construction Details</b>			
7.	Tensile Strength	§ 9.81 x 4W Newton (where w is the mass of 1 Km of cable in Kg)	
8.	FRP Rod EAA coated	§ 2.5 +0.1/-0.0 mm for 48F § 2.3 +0.1/-0.0 mm for 24/12F	
9.	Tube ID(min)	§ 1.7 mm for 48F § 1.4 mm for 24/12F	
10.	Tube OD	§ 2.4 ± 0.1 mm for 48F § 2.2 ± 0.1 mm for 24/12F	
11.	48F	No.	Colour Schema
		Fibre per tube	12 BL,OR,GR, BR,SL,WH, RD, NAT
		No. of Loose tube	4 BL,OR,GR, BR, SL,WH
12.	24F	No.	Colour Schema
		Fibre per tube	4 BL,OR,GR, NAT
		No. of Loose tube	6 BL,OR,GR, BR, SL,WH
13.	12F	No.	Colour Schema
		Fibre per tube	4 BL,OR,GR, NAT
		No. of Loose tube	3 BL,OR, SL
14.	No. of dummy cord	§ 48F : 2 § 24F : 0 § 12F : 3	
15.	Tube stranding layover strength for 48F/24F/12F	90-110 mm	
16.	Min. Sheath Thickness	§ Inner: 1.0 mm § Outer: 1.8 mm	
17.	Outer Sheath Colour	§ Black with white stripes	
18.	Aramid Quantity (Minimum)	§ 10.0 Kg/Km for 48/24/12F of 100 Km/hour § 13.0 Kg/Km for 48F of 150 Km/hour	
19.	Cable Diameter	§ 14.0 ± 0.5 mm for 24/12F of 100 Km/hour	

## Volume- II

SL No.	Parameter	Minimum Specifications
		ξ 14.5 ± 0.5 mm for 48F of 100/150 Km/hour
20.	Cable Weight	ξ 150 -180 Kg/Km for 24/12F of 100 Km/hour ξ 160-190 Kg/Km for 48F of 100/150 Km/hour
21.	Cable to be designed to Fibre strain value of	0.1%
22.	Cable to be tested at defined load for fibre strain value of	0.25%

Table 56: Specifications for Aerial ADSS OF Cable

### 1.2.3. Other Standards

Sl. No.	Document No.	Title/Document Name
1.	GR No. GR/OFT-01/03. APR 2006	Tools for installation & Operating the OFC & for assembly of the OF Splice Closures.
2.	GR No. TEC/GR/TX/ORM-01/04 SEP.09	Specification for Raw Material used in manufacturing of OF Cables.
3.	GR No. G/CBD-01/02. NOV 94	Drum specifications for Cable ends.
4.	ITU-T Rec. G- 652 D	ITU – T Recommendations
5.	GR-20-CORE Issue4, 2013	Generic Requirement for Optical fibre Cable (Bell Core)
6.	ISO 9001:2008	International Quality Management System
7.	IEEE 1222 - 2004	IEEE Standard for ADSS Cable
8.	IEC – 60793-1, IEC – 60793-2-50,	Test Method for optical fibres
9.	IEC 60794-1-2-E1, IEC 794-1-2-E2, IEC 794-1-2-E3, IEC 794-1-2-E4, IEC 794-1-2-E6, IEC 794-1-2-E7, IEC 794-1-2-E9, IEC 794-1-2-E10, IEC 794-1-E11 IEC 794-1-2-F1, IEC 794-1-2-F3, IEC 794-1-2-F5, IEC 60068-2-1, IEC 61395, IEC 189	Test Methods for optical fibres
10.	IEC 60794-4	Test Methods for Aerial Optical Fibre Cables along electrical power lines
11.	ASTM D 566, ASTM D 790, ASTM D 1248, ASTM D 1693, ASTM G 53-96, ASTM D 1603, ASTM D 566, ASTM D 1693, ASTM D 638, ASTM D 566, ASTM D 817, ASTM D 3895, ASTM D 3349, ASTM D 746, ASTM G 53, ASTM D 150, ASTM D 149, ASTM D 257, ASTM D 2303-85	
12.	FOTP – 62, FOTP – 98, FOTP – 89	Test Methods
13.	BS 2782 (Method 720 A & 620 A – D), IS – 7328 -1192 Annex. B	Test Methods
14.	EIA 359-A IEC Publication 304(4)	Colour Standard
15.	EIA/TIA 455-73, EIA/TIA-455-81 A(B9), EIA/RS-455-37	Test Methods

Table 57: Other Standards for Aerial Drop Cable

### **1.2.3. Functional Requirements**

- ξ The design and construction of Optical fibre cable shall be inherently robust and rigid under all conditions of installation, operation, adjustment, replacement, storage and transport. The cable shall possess good performance characteristics such as anti-impact, anti-vibration, anti-bending, prevention of thermal ageing, etc. All elements consisting of ADSS cable shall be non-metallic
- ξ The Optical fibre cable shall be able to work in a saline atmosphere in coastal areas and should be protected against corrosion.
- ξ Life of cable shall be at least 25 years. Necessary statistical calculations shall be submitted by the manufacturer, based upon life of the fibre and other component parts of the cable. The cable shall meet the cable aging test requirement.
- ξ It shall be possible to operate and handle the Optical fibre cable with tools as per GR No. GR/OFT-01/03 APR 2006 and subsequent amendment, if any. If any special tool is required for operating and handling the optical fibre cable the same shall be provided along with the cable.
- ξ It shall be possible to install the ADSS cable with accessories and fixtures as per specifications given in this tender
- ξ The Optical fibre cable supplied shall be suitable and compatible to match with the dimensions, fixing, terminating & splicing arrangement of the splice closure. The cable supplied shall also meet other requirement of splice closure (GR No. TEC/GR/TX/OJC-002/03/APR-2010) and subsequent amendments, if any.
- ξ The manufacturer shall submit an undertaking that the optical and mechanical fibre characteristics shall not change during the lifetime of the cable against the manufacturing defects.
- ξ It is mandatory that the Optical fibre cable supplied in a particular route is manufactured from a single source of optical fibres.

### **1.2.3. Colour Qualification and Primary coating Test**

#### **Colour Qualification Test:**

- a) MEK Rub Test (Methyl Ethyl Ketone Test):

To be tested by using soaked (Solvent) tissue paper for ten strokes unidirectional on 10 cm length of fibre. No colour traces shall be observed on the tissue paper after testing.

- b) Water immersion Test (Type Test):

To be tested for coloured fibre for 30 days. After the test Colour qualification, Attenuation measurement & Strippability test are to be taken.

#### **Primary coating Test:**

- a) Fourier Transform Infrared Spectroscopy (FTIR) Test:

To be tested to check the curing level of coating on the surface of natural fibre. The curing level shall be better than 90%.

- b) Adhesion Test:

To be tested by using soaked (Solvent) tissue paper for ten strokes unidirectional on 10 cm length of fibre. No coating shall be observed on the tissue paper after testing.

### **1.2.3. OFC Construction Specifications**

The Optical Fibre Cable shall be designed to the parameters mentioned in the specifications. The manufacturer shall submit designed calculations and the same shall be studied and checked.

1. **Secondary Protection:** Primary coated coloured fibres may be protected by loose packaging within tube, which shall be filled with thixotropic jelly. The dimensions of tube shall be as per specifications

## Volume- II

---

2. **Strength Member:** FRP non - metallic strength member shall be used in the center of the cable core. The strength member in the cable shall be for strength and flexibility of the cable and shall have anti buckling properties. The FRP shall keep the fibre strain within permissible values.
3. **Cable Core Assembly:** Fibre coated fibres in loose tubes stranded together around a central strength member using helical or reverse lay techniques shall form the cable core.
4. **Core Wrapping:** The main cable core containing fibres shall be wrapped by the layer/layers of water swellable tape and binder (as per of Section IX of GR No. TEC/GR/TX/ORM-01/04/SEP-09)
5. **Moisture barrier (protection):** Cable core (containing Tube/FRP & core wrapping) shall be protected by water swellable yarns as per XIX of GR No. TEC/GR/TX/ORM-01/04/SEP-09
6. **Filling compound:** Filling compound used in the loose tube shall be compatible to fibre, secondary protection of fibre, core wrapping and other component part of the cable. The drip point shall not be lower than +70°C. The fibre movement shall not be constrained by stickiness & shall be removable easily for splicing. Reference test method to measure drop point shall be as per ASTM D 566. The thixotropic filling compound (jelly) shall be as per the GR No. TEC/GR/TX/ORM-01/04/SEP-09 and subsequent amendment issued, if any.
7. **Inner Sheath:** Non-metallic moisture barrier sheath may be applied over and above the cable core. The core shall be covered with tough weather resistant High Density Polyethylene (HDPE) sheath, black in colour (UV Stabilized). Thickness of the sheath shall be uniform & shall not be less than 1.0 mm. The sheath shall be circular, smooth, free from pin holes, joints, mended pieces and other defects. Reference test method to measure thickness shall be as per IEC 189 para 2.2.1 and para 2.2.2.  
Note: HDPE material, black in colour, from the finished cable shall be subjected to following tests (on sample basis) and shall confirm to the requirement of the material as per GR No. TEC/GR/TX/ORM-01/04 SEP.09(Section III).
  - a. Density
  - b. Melt flow index
  - c. Oxidative Induction time
  - d. Carbon black content
  - e. Carbon black dispersion
  - f. ESCR
  - g. Moisture content
  - h. Tensile strength and elongation at break
8. **Reinforcement:** Cable shall be helically reinforced with aramid yarn in the periphery over the inner sheath. The aramid yarn shall be uniformly and equally distributed on the entire periphery (circumference) of the cable. The quantity of the aramid yarn used per kilometer length of the cable shall be as per the specifications mentioned. The aramid yarn shall be as per the as per GR No. TEC/GR/TX/ORM-01/04 SEP.09(Section XVII) and subsequent amendments if any
9. **Outer Jacket:** Circular and uniform tough weather resistant UV stabilized polyethylene compound (HDPE) material sheath/jacket, black in colour with white stripes, shall be provided over and above the reinforcement of aramid yarn. The thickness of the outer sheath/jacket shall be minimum 1.8 mm. The outer sheath shall be free from pin holes, joints, scratches, mended pieces and other defects, etc and it shall have a smooth finish.  
**Note:** HDPE material (black in colour) from finished cable, shall be subjected to following tests (on sample basis) and shall confirm to the requirement of the material as per the GR no. TEC/GR/TX/ORM-01/04/SEP-09:
  - i) Density
  - ii) Melt flow index
  - iii) Oxidative Induction time
  - iv) Carbon black content
  - v) Carbon black dispersion
  - vi) ESCR
  - vii) Moisture content
  - viii) Tensile strength and elongation at break
10. **RIP Cord**  
The suitable ripcords (two each for inner & outer sheath) shall be provided in the cable, which shall be used to open the both sheaths of the cable. It shall be capable of consistently slitting the sheath without breaking for a length of 1 meter at the installation temperature. The ripcords and suitable ripcord for inner sheath) shall be properly waxed to avoid wicking action and shall not work as water carrier.  
The ripcords used in the cable shall be readily distinguishable from any other components utilized in the cable construction.

### 1.2.3. Mechanical Characteristics and Tests on Optical Fibre Cable

1. Tensile strength Test:

A load of value  $T(N) = 9.81 \times 4W$  Newtons (where  $w$  is the mass of 1 Km of cable in Kg) on the cable sustained for 10 minutes shall not produce a strain of 0.25% in the fibre and shall not cause any permanent physical and optical damage to the cable. The attenuation shall be noted before and after the completion of test. The change in attenuation of each fibre after the test shall be  $\leq 0.05$  dB both for 1310 nm and 1550 nm wavelength.

**Method** EC 60794-1-2-E1.

2. Abrasion Test:

The cable surface shall be abraded for 100 cycles with needle (wt. 150 gm) having diameter of 1 mm with 500 grams eight (Total weight more than equal 650 gms.) for 1 minute shall not cause any perforation and loss of legibility of the marking on the sheath.

**Method** EC-60794-1-2-E2 or by any other international test method

3. Crush Test (Compressive Test):

A compressive load of 2200 Newton applied between the plates of dimension 100 x 100 mm for 10 minutes shall not damage the cable. The attenuation shall be noted before and after the completion of test. The change in attenuation of the fibre after the test shall be  $\leq 0.05$  dB both for 1310 nm and 1550 nm wavelength.

**Method** EC 60794-1-2-E3.

4. Impact Test:

Impact caused by a mass weight of 50 Newton, when falls freely from a height of 0.5m on the surface of radius 300mm shall be withstood by cable. Ten such impacts shall be applied at same place. The attenuation shall be noted before and after the completion of test. The change in attenuation of the fibre after the test shall be  $\leq 0.05$  dB both for 1310 nm and 1550 nm wavelength.

**Method** EC 60794-1-2-E4.

5. Repeated Bending/Cable cyclic flexing:

<b>Parameters:</b>	
Weight	5 Kg
Length of the cable sample	5 M (minimum)
Minimum distance from Pulley centre to holding device	216mm
Minimum distance from Wt. to Pulley centre	457mm
Pulley Diameter	20 D (D - cable diameter)
Angle of Turning	90 degrees
No. of cycles	30
Time Required per cycle	1 min
Total cycles	25

The fibre shall not break during repeated bending of the cable. The attenuation shall be noted before and after the completion of test. The change in attenuation of each fibre after the test shall be  $\leq 0.05$  dB both for 1310 nm and 1550 nm wavelength.

**Method** EC 60794-1-2-E6/IEEE1222

## Volume- II

---

### 6. Torsion/Cable twist Test:

The length of the specimen under test shall be 2 meters and the load shall be 100 N. The cable shall withstand 10 such complete cycles. The cable shall be examined physically for any cracks or tearing on the outer sheath. The fibres and other component part of the cable shall not be damaged. The attenuation shall be noted before and after the completion of test. The change in attenuation of the fibre after the test shall be  $\leq 0.05$  dB both for 1310 nm and 1550 nm wavelength.

**Method** EC 60794-1-2-E7/IEEE 1222

### 7. Kink Test:

The sample length shall be 10 times the minimum bending radius and the minimum bending radius of the cable shall be 20D (D- diameter of the cable). The loop to the minimum bend radius shall not form any kink on the cable. The change in attenuation of the fibre after test shall be  $\leq 0.05$  dB both for 1310 nm & 1550 nm wavelength.

**Method** EC 60794-1-2-E10.

### 8. Cable Bend Test:

The cable shall withstand repeated flexing when fibre wrapped and unwrapped 4 complete turns of 10 complete cycles around a mandrel of 20 D, where D is the diameter of the cable. There shall be no on the outer sheath of the cable. The change in attenuation of the fibre after the test shall be  $\leq 0.05$  dB both for 1310 nm and 1550 nm wavelength.

**Method** EC 60794-1-2-E11 (Procedure-I).

### 9. Snatch Test

<b>Parameters:</b>	
Length of the cable sample	4.5 Metres
Sag	300 mm
Testing load	300 N
Radius of impacting surface	12.5 mm
Height	100 mm
No. of times	10

There shall be no permanent physical damage to the cable. The change in attenuation of the fibre under test shall be  $\leq 0.05$  dB for 1310 nm and 1550 nm wave length.

**Method** EC 60794-1-E9

### 10. Cable Bend Test at High & Low Temp (Type Test):

<b>Parameters:</b>	
Test Temperature	-40 deg. C to +70 deg. C
Mandrel Diameter	20D (D-diameter)
No. of turns	4
Conditioning time duration	24 hours at each temperature.

There shall be no permanent physical damage to the cable. The change in attenuation of the fibre under test shall be  $\leq 0.05$  dB for 1310 nm and 1550 nm wave length.

**Method** EIA RS-455-37

## Volume- II

### 11. Temperature Cycling(Type Test):

<b>Parameters:</b>	
Standard Cable length of drum	4 Km/2 Km + 5%
Temperature Range for storage	-40 deg. C to +70 deg. C
Temperature range for operation	-40 deg. C to +70 deg. C
Rate of change of temperature	1 deg. Per minute
	12 hrs each at temp. given below. TA2 temp.: -40°C TA1 temp.: -10°C. TB1 temp.: + 60°C. TB2 temp.: + 70°C.
Temperature cycling	
No. of temperature cycles	2

The change in attenuation of the fibre under test shall be  $\leq 0.05$  dB for 1310 nm and 1550 nm wave length respectively for the entire range of temperature.

**Method** EC 60794-1-2-F1/IEEE 1222(Annexure E)

### 12. Cable aging Test (Type Test):

After temperature cycle test, the cable shall be exposed to  $85 \pm 2$  degree C for 168 hours. The change in attenuation of each fibre after the test shall be  $\leq 0.05$  dB at 1310 and 1550 nm. The attenuation measurement of the test cable after stabilization at ambient temperature for 24 hours. The attenuation changes are to be calculated with respect to the base line attenuation values measured at room temperature before temperature cycling.

**Method** IEEE 1222(Annexure F)

### 13. Water Penetration Test (Type Test):

A circumferential portion of the cable end(loose tube) shall be supported horizontally facing two metre water head, containing sufficient quantity of water soluble fluorescent dye for 7 days at ambient temperature. The cable sample under test shall be ripped open after the test and then it shall be examined for seepage of water into the cable and distance shall be noted. It shall not be more than 20 cm. It shall not be more than one metre. No other coloured dye shall be detected at the end of the 3m cable length when examined with ultraviolet light detector. For bulk testing, test should be conducted for 24 hours

**Method** EC 60794-1-2-F5(fig. B) 1999

### 14. Cable Freezing Test (Type Test):

The magnitude of the maximum attenuation change of each individual fibre shall not be greater than 0.15 dB and the cable shall not show the evidence of cracking or splitting.

**Method** OTP 98

### 15. Test of Figure of 8 (Eight) on the cable (Type Test):

It shall be possible to make figure of 8 of minimum 1000 meters of the cable uncoiled from the cable reel without any difficulty. The diameter of each loop of the figure of 8 shall be maximum 2 meters. No visible damage shall occur.

### 16. Flexural Rigidity Test on the optical fibre cable (Type Test):

## Volume- II

Test Specs: The cable shall withstand the Flexural Rigidity Test as per the test method and there shall be no cracks visible to the naked eye on the sheath of the cable. The attenuation shall be noted before and after the completion of test. The change in attenuation of the fibre after the test shall be < 0.05 dB at 1310nm and 1550nm wavelengths.

**Method** ASTM D –790

### 17. Static Bend Test

Objective: To check the Cable under Static Bend.

Test Specs: The cable shall be subjected to static bend test. The optical fibre cable shall be bend on a mandrel having a Diameter of 10 D (D is diameter of the cable).

Requirement: The change in attenuation of the fibre after the test shall be ≤0.05 dB for 1310 nm and 1550 nm wavelengths. Sheath shall not show any cracks visible to the naked eye when examined whilst still wrapped on the mandrel.

**Method** ASTM D790.

### 18. Cable Jacket Yield Strength and Ultimate Elongation:

Jacket Material	Minimum Yield Strength		Minimum Elongation (%)
	(MPa)	(psi)	
HDPE un-aged	16.5	2400	400
HDPE aged	12.4	1800	375

The aged sample taken from a completed cable conditioned at 100 ± 2°C for 120 hours before testing before testing at cross-head speed of 50 mm per minute.

**Method** FOTP-89 or ASTM 1248 Type III class

### 19. Drip test on the cable(Seepage of filling or flooding compound)

<b>Parameters:</b>	
Length of the Cable sample	30 cm
Length of the open end of cable sample	5 cm
Temperature	+70 deg. C
Period	24 hours

Objective: The purpose of this test is to determine the ability of jelly in the O.F. cable to withstand a temperature of 70 degree C.

The cable sample shall be of 30 cm. length of the cable with one end sealed. Outer sheath, aramid yarn, and FRP shall be removed for 5 cm from the open end of sample. The paper placed below the cable sample, kept vertically inside the oven for 24 hours at 70 deg. C shall be examined for dripping of the jelly after 24 hours and there shall be no jelly drip or oily impression on the paper.

**Method** TIA/EIA 455-81-A-1992[B9]

### 20. ESCR ( Environment Stress Cracking Resistance) Test:



## Volume- II

The outer sheath of the optical fibre cable shall be checked and tested for ESCR. There shall not be any visible cracks on the surface of the outer sheath, when examined with the help of a magnifying glass at the end of 1000 hours in a 10% Igepal solution.

**Method**ASTM D-1693

### 21. UV Radiation Test:

<b>Parameters:</b>	
Type of lamp	40 Watt UV-B lamp with a peak emission at 313 nm
Duration	1000 hours

Four test samples of the finished cable of the required length (as per test chamber specifications) are to be prepared and two samples are to be kept inside. These test samples are to be compared after test with 2 other samples kept outside. There shall be no fading or change in the colour of the markings and that of outer sheath.

**Method**ASTM G-53-96(ASTM G-154)

### 22. Check of the quality of the loose tube (containing optical fibre):

#### a. Embrittlement Test of loose tube

<b>Parameters:</b>	
Minimum length of sample	85 mm
Outside diameter of the tube	$\leq 2.5$ mm
Speed of movable jaw	50 mm per minute
Safe bend diameter of tube	15D (d-outside diameter of loose tube)

The minimum length of the test sample depends on the outside diameter of the loose tube and shall be 85 mm for tubes up to 2.5 mm outside dia. The length of the bigger tubes should be calculated by using the following equation:

$$L_o > 100 \times \sqrt{[(D^2 + d^2)]/4}$$
 where

$L_o$  = Length of tube under test.

$D$  = Outside dia of loose tube.

$d$  = Inside dia of loose tube.

The tube shall not get embrittled. No ink should appear on the tube up to 15 D, where D is the outside diameter of the loose tube. There shall also not be any physical damage or mark on the tube surface.

#### b. Kink Resistance Test on the Loose Tube

<b>Parameters:</b>	
Tube sample	Loose tube with fibre & gel
Min bend radius of tube	15D (d-outside diameter of loose tube)
No. of times	4

No damage or kink should appear on the surface of the tube.

### 23. Drainage Test for loose tube:

<b>Parameters:</b>	
Sample size	30 cm tube length
Tube in horizontal position	24 hrs. at ambient temperature

## Volume- II

---

Tube in vertical position	24 hrs at 70 deg. C
---------------------------	---------------------

There shall be no oil or gel in the breaker

24. Check of easy removal of sheath:

300 mm sheath shall be removed easily by using removal tool and no undue extra force is applied to remove the sheath. No component part of the cable shall be damaged.

25. Check of the effect of aggressive media on the cable

<b>Parameters:</b>	
Aggressive media solution	PH – 4 & PH -10
Length of the sample of finished cable	600 mm
Duration of test	30 days

Effect of aggressive media shall be checked by the solution of PH4 and PH10 on test samples of the finished cable, each of 600 mm in length with sealed ends for 30 days. There shall be no corrosion on the sheath and other markings of the cable.

**Method**SO 175

26. Electrical Test

Objective: To demonstrate the resistance of the Cable sheath to erosion and tracking under combined electrical and mechanical stresses.

Requirement: Tracking on the outside of the sheath shall not result in erosion at any point of time.

**Method**IEEE 1222 – 2003 (Annexure A)

27. Aeolian Vibration Test

Objective: To assess the fatigue performance of the cable and optical characteristics of the fibres under the typical aeolian vibrations.

Test Specs: The cable shall be subjected to a minimum of 100 million vibration cycles. The frequency of the test span shall be equal to and maintained at the nearest resonant frequency produced by a 16.1kmph wind. The free loop peak-to-peak antinode amplitude shall be maintained at a level equal to one-half the diameter of the cable.

In the initial stages, test spans requires continuous attention and recordings shall be taken at 15 mins until the test span has stabilized. After the span has stabilized, readings shall be taken a min. of 2 times per day, typically at the start and end of the working day. The test shall be performed on a min of 95 m sample of ADSS cable. About 45 m section of the cable is placed in a test span at a 2 deg. Static angle with use of ADSS dead end and suspension clamps.

Requirement: The change in attenuation of the fibre after the test shall be  $\leq 0.05$  dB for 1310 nm and 1550 nm wavelengths. The cable shall be examined for any cracks, tearing of outer sheath and damage on any other components of the cable.

**Method**IEC 60794-1-2-E19/IEEE1222 – 2003 (Annexure B)

28. Galloping Test

Objective: To assess the fatigue performance of the cable and optical characteristics of the fibres under the typical galloping vibrations.

## Volume- II

---

**Test Specs:** The cable shall be subjected to a minimum of 100000 galloping cycles. The frequency of the test span shall be single loop resonant frequency. The min peak-to-peak antinode amplitude/loop length ratio shall be maintained at a value 1/25, as measured in the active span. Mechanical and optical data shall be read approximately every 2000 cycles. The optical power meters shall be continuously monitored beginning at least one hour before the test and ending at least two hours after the test.

**Requirement:** The change in attenuation of the fibre after the test shall be  $\leq 0.05$  dB for 1310 nm and 1550 nm wavelengths. The cable shall be examined for any cracks, tearing of outer sheath and damage on any other components of the cable.

**Method** IEEE 1222 – 2003 (Annexure C)

### 29. Sheave Test (Type test)

**Objective:** To verify that the installation of the ADSS cable will not damage or degrade their performance.

**Test Specs:** A 2m min length of ADSS test sample cable shall be pulled 120 times forward and backward through the sheave (60 times in each direction). Angle of the pull must be 70 deg. The diameter of the sheave for the angle of pull shall be determined by ADSS cable manufacturer. Before the first pull, the beginning, midpoint and end of this length shall be marked. Micrometer readings of the diameter shall be taken and recorded before the first pass through the sheave and thereafter every tenth cycle. The output of the optical power meter shall be monitored continuously during the test. After the test is completed, the ADSS cable shall be removed in the test section, and the cable shall be visually examined for any surface damage. The ADSS cable shall be dissected to observe for any signs of damage to the inner structure.

**Requirement:** The change in attenuation of the fibre after the test shall be  $\leq 0.05$  dB for 1310 nm and 1550 nm wavelengths. The cable shall be examined for any cracks, tearing of outer sheath and damage on any other components of the cable.

**Method** EC 60794-1-2-E9/IEEE 1222 – 2003 (Annexure D)

### 30. Creep Test (Type test)

**Test Specs:** A creep test shall be performed on the ADSS cable sample of 10m length. The cable shall be terminated at each end and a tension of at least 50% of the maximum rated cable loads shall be applied and sustained for a duration of at least 1000 hours. The elongation of the cable versus time shall be measured at suitable intervals and recorded.

**Requirement:** The change in attenuation of the fibre after the test shall be  $\leq 0.05$  dB for 1310 nm and 1550 nm wavelengths. The cable shall be examined for any cracks, tearing of outer sheath and damage on any other components of the cable.

**Method** EC 61395

### 31. Tracking & Erosion Test (Type test)

Type test is conducted during product approval and bulk test are conducted during bulk approval.

**Method** ASTM D2303 - 97

## 1.2.3.6 Cable Marking

- ξ A long lasting suitable marking shall be applied in order to identify this cable from other cables. The cable marking shall be imprinted (indented). The marking on the cable shall be indelible of durable quality and at regular intervals of one meter length. Alternatively, permanent printing with laser shall also be acceptable. In case of laser printing method, the impression shall not exceed, the depth of 0.15mm. The accuracy of the sequential marking must be within -0.25% to +0.5% of the actual measured length. The markings on the

## Volume- II

---

cable must not rub off during normal installation and in life time of optical fibre cable. The total length of the cable shall not be in negative tolerance.

- ξ The marking shall be in contrast colour(white) over the black sheath (jacket) and shall be one by hot foil indentation method. The colour used must withstand the environmental influences experienced in the field, permanent and insoluble in water.
- ξ The type of legend marking on O.F. cable shall be as follows:
  - a) Company Legend
  - b) Legend containing telephone mark & international acceptable Laser symbol
  - c) Type of Fibre– G.652D
  - d) Number of Fibres
  - e) Type of cable - Loose tube – ADSS ( Type II A)
  - f) Year of manufacture
  - g) Sequential length marking
  - h) Authority's name – KFON
  - i) Diameter of the cable
  - j) Cable ID

### 1.2.3. Cable Ends

- ξ Both cable ends (the beginning end and end of the cable reel) shall be sealed and readily accessible. Minimum 5 meter of the cable of the beginning end of the reel shall accessible for testing. Both ends of the cable shall be kept inside the drums and shall be located so as to be easily accessible for the test. The drum (confirming to GR No. G/CBD-O1/02 Nov. 94 and subsequent amendment) should be marked to identify the direction of rotation of the drum. Both ends of cable shall be provided with cable pulling (grip) stocking and the anti-twist device (free head hook). The wooden drums shall be properly treated against termites and other insects during transportation and storage. The diameter of the cable shall also be marked on the cable drum. The manufacturer shall submit the methodology used for the same
- ξ An anti-twist device (Free head hook) shall be provided, attached to the both the ends of the cable pulling arrangement. The arrangement of the pulling eye and its coupling system along with the anti-twist system shall withstand the prescribed tensile load applicable to the cable.

### The nominal drum length

- ξ Length of OF Cable in each drum shall be 2 Km 10% / 4Km 10% / 8Km± 10% / 10Km ± 10% and shall be supplied as per the order. The variation in length of optical fibre cable, as specified above (in each drum), shall be acceptable.
- ξ The fibres in cable length shall not have any joint.
- ξ The drum shall be marked with arrows to indicate the direction of rotation.
- ξ Packing list supplied with each drum shall have at least the following information:
  - a) Drum No.
  - b) Type of cables: ADSS Type II A
  - c) Physical Cable length
  - d) No. of fibres
  - e) Length of each fibre as measured by OTDR
  - f) The Cable factor - ratio of fibre/cable length
  - g) Attenuation per Km. of each fibre at 1310 & 1550 nm
  - h) Authority's Name
  - i) Manufacturers Name, Month, Year and Batch No.
  - j) Group refractive index of fibre.
  - j) Purchase Order No.
  - k) Cable ID

### Colour coding in O.F. Cables:

## Volume- II

---

- § The colorant applied to individual fibres shall be readily identifiable throughout the lifetime of the cable and shall match and conform to the Munsell Colour Standards (EIA- 598-C) and also IEC Publication 304(4).
- § **Colour Coding Scheme:** the loose tubes are placed in circular format, the marking to indicate the loose tube no. "1" shall be in blue colour followed by loose tube no.2 of orange and so on for other tubes as per the colour scheme given in the technical specifications and complete the circular format by placing the dummy /fillers at the end.

### 1.2.3. Quality Requirements

The cable shall be manufactured in accordance with the international quality standards ISO 9001-2008 (latest issue) for which the manufacturer should be duly accredited. The Quality Manual shall be submitted by the manufacturer.

### 1.2.3. Raw Material

- § The cable shall use the raw materials approved against the GR No. TEC/GR/TX/ORM-01/04 SEP.09 and the subsequent amendment issued, if any.
- § Any other material used shall be clearly indicated by the manufacturer. The detailed technical specifications of such raw materials used shall be furnished by the manufacturer at the time of evaluation/testing.
- § The raw materials used from multiple sources is permitted and the source / sources of raw materials (Type and grade) from where these have been procured shall be submitted by the manufacturer.
- § The manufacturer can change the raw material from one approved source to other approved source with the approval of QA wing of purchaser. The change of source/grade of SM Optical Fibre shall call for fresh evaluation/testing.
- § The ATPE black in colour used for outer sheath shall be UV stabilized and shall withstand UV test for 2,000 hours(minimum). A test certificate from a recognized laboratory or institutemay be acceptable for the UV stability of the ATPE sheath material.
- § The material used in optical fibre cable must not evolve hydrogen that will affect the characteristics of optical fibres. A test certificate from a recognized laboratory or institutemay be acceptable.

### 1.2.3.10. Cable Material Compatibility

Optical fibre, buffers/core tubes, and other core components shall meet the requirements of the compatibility with buffer/core tube filling material(s) and/or water-blocking materials that are in direct contact with identified components within the cable structure (This shall be tested as per clause no. 6.3.3 of Telecordia document GR-20-CORE issue 4, 2013.)

**Note**The tests may be conducted in house (if facility exist) or may be conducted at CACT or any other recognized laboratory. The test certificate may be accepted and the tests may not be repeated subsequently, in next type approvals, if the raw material used is of same make and grade.

### 1.2.3.11. Documentation

- § Complete technical literature in English with detailed cable construction diagram of various sub-components with dimensions, weight & test data and other details of the cable shall be provided.
- § All aspects of installation, operation, maintenance and fibre splicing shall also be covered in the handbook. The pictorial diagrams of the accessories (with model no. and manufacturer name) supplied along with the cable as package shall be also be submitted. A hard as well as soft copy of the manuals shall be provided.

### 1.2.3.12. Safety

- § The material used in the manufacturing of the self-supporting Optical fibre cables shall be non-toxic and dermatologically safe in its life time and shall not be hazardous to health. The manufacturer shall submit MSDS (Material safety Data Sheet) for all the material used in manufacturing of OF Cable to substantiate the statement.

**1.2.3.13. Factory Acceptance Test (FAT)**

The FAT on cable accessories & fixtures of all dielectric self-supporting optical fibre cable shall include the following minimum tests as specified in Table below:

SI. No.	Factory Acceptance Test
1	Visual and dimensional checks of all components
2	Tensile test
3	Slip test
4	Galvanising test
5	Wrapping test
6	Hardness test

*Table 58: FAT for ADSS Cable*

Equipment shall not be shipped to the Authority until required factory tests are completed satisfactorily, all variances are resolved, full test documentation has been delivered to the employer, and the employer has issued dispatch Certificate. Successful completion of the factory tests and the Buyer approval to shipment, shall in no way constitute final acceptance of the cable and associated accessories and fixtures.

For the ADSS cable hardware fittings & accessories, the minimum sampling rate, and batch acceptance criteria shall be as defined in IS 2486.

FAT tests shall include supply of proper calibration certificates, demonstration of satisfactory performance, evidence of correct equipment configuration and manufacturer's final inspection certificate / report.

**1.2.3.14. Site Acceptance Test (SAT)**

Prior to installation, every spooled fibre optic cable segment shall be tested for compliance with the Pre-shipment data previously received from the manufacturer. This requirement will preclude the installation of out of specification cable segments that may have been damaged during shipment. During the installation, spliced cable segments shall be tested and documented. Upon completion of a continuous cable path, all fibres within the cable path shall be demonstrated for acceptance of the cable path. Fibre Optic cable field testing stages are provided below.

SI No.	Test Description	Type of Test	Approximate Test Schedule
1.	Pre-installation physical inspection.	Visual Inspection of the Cable / Drum / Batons.	Prior to cable installation.
2.	Pre-installation OTDR (Length)	OTDR distance (one direction)	Prior to cable installation.
3.	Pre-installation OTDR (Attenuation)	OTDR fibre attenuation (One direction)	Prior to cable installation.
4.	Per splice attenuation.	OTDR bidirectional splice loss.	At completion of cable route.
5.	Per splice OTDR	OTDR bidirectional.	At completion of cable route.
6.	Inspection of splice enclosure / cable routing	Visual inspection	During installation / After completion of cable route
7.	Inspection of joint seal.	Visual inspection	During installation / After completion of cable route

## Volume- II

SI No.	Test Description	Type of Test	Approximate Test Schedule
8.	Fibre Continuity & attenuation.	Power through connector	At completion of cable route.
9.	OTDR test	OTDR Bidirectional	At completion of cable route.

Table 59: Site Acceptance Tests

Complete and indexed records of all factory and site acceptance tests results shall be submitted to Authority for approval by the supplier in hardcopy & softcopy.

### 1.2.4. Underground OFC - 48 F - Armoured Non-Metallic

Specifications/test procedures for the UG cable and PLB duct shall be same as the specifications/test procedures for Fibre Optic Approach cable and PLB duct

### 1.2.5 Accessories for Aerial ADSS Fibre Cable - Wedge Type

This Technical Specification contains the requirements for Installation Accessories & Fixtures to be used for erection of the Self Supporting Metal free Aerial / ADSS Optical Fibre Cables on the existing overhead alignments or Power line alignments up to 100 m of span length.

#### Types of Installation Accessories

The Wedge types of Installation Accessories are as mentioned below:

- i) Tension (Dead End) Assembly
- ii) Universal Pole Bracket
- iii) Suspension Clamp Assembly
- iv) Adjustable Cable Storage Bracket
- v) Stainless Steel Strap with Buckle
- vi) Down Lead Clamps

#### 1.2.5. Anchoring (Dead End) Assembly

Anchoring assemblies shall be used to firmly hold ADSS cable to a concrete, wood or steel pole and transmit the mechanical tension,

- ☞ at the end of a run
- ☞ at Tensioning Points
- ☞ at a major change in direction of over 20 degrees.

Each Anchoring Assembly includes:

- ☞ Two numbers of wedge type tension Clamps (Dead End Clamp)
- ☞ One number Pole bracket or wall bracket (Universal Pole Bracket)

Anchoring assemblies shall be supplied in sets to ensure compatibility of the materials

#### 1.2.5. Universal Pole Bracket

Universal Pole Bracket shall be used for Tensioning (Dead End) Assembly.

#### 1.2.5. Suspension Clamp Assembly

Suspension Clamp Assembly shall be used for holding the ADSS cable at an intermediate point of support such as a pole. It can accommodate small angles of deviation up to 20 deg.

Each Suspension Assembly shall consist of:

## Volume- II

---

- § One number Suspension Clamp (Body with Flange).
- § One number of elastomer liner allowing ADSS to slide in case of unexpected dissymmetric load on one span.

The Body and Flange shall be designed to hold the ADSS cable through a liner kept in a clamp.

Suspension Assemblies shall be supplied in sets to ensure compatibility of the materials.

### **1.2.5.Adjustable Cable Storage Bracket**

Adjustable Cable Storage Bracket is used to store the excess cables which is being maintained in the middle of the line and to use at the time of joints.

### **1.2.5.Stainless Steel Strap and Buckles:**

- a) The Stainless steel strap shall consist of stainless steel strap of size 20mm  $\pm$ 0.2 x 0.7mm  $\pm$ 0.05 mm and shall have tensile strength of 7.5KN min., elongation 30% Min, finish 2B.
- b) Tensile strength of strap shall be minimum 7.5KN which shall be tested on a loop with Buckle. Number of loops for mounting the bracket on pole shall be allocated as per load requirement for Tension (Dead-end) and Suspension clamp specified in this specification.
- c) Min two loops of 0.75 meter each with one Buckle shall be considered for attaching the brackets to the poles.
- d) The SS Strap shall be engraved with the name of the Manufacturer, month and year of manufacturing and length at a distance of approx. 250mm for traceability.
- e) S S Strap shall be supplied in 50 meter roll in plastic dispenser casing with indication of remaining length.
- f) The S S Buckle to suit above Strap shall be used to tension & fix it. It shall have a slot width of not less than 20.5 mm x 1.5 mm
- g) Buckles shall be supplied in plastic bags containing 100 pcs per bag.

### **1.2.5.Down Lead Clamps**

Down Lead Clamps shall be used to properly fix the cable on the pole to avoid the movement of the cable under wind condition which may lead to damage of the cable. The Down Lead Clamps shall have provision to fix it on the pole by stainless Steel straps

### **1.2.5.Raw materials for Installation Accessories**

#### **Raw Material for Dead End Clamp:**

The clamp body shall consists of an Aluminium alloy, flexible rope sling attachment loop (“bail”) of stainless steel and self-adjusting plastic wedges which shall Tension/hold the cable. The following key criterion shall be followed for the design of the same:

- i) There shall be no losable part in the process of clamping arrangement
- ii) Locking mechanism shall be wedge type self-locking. Wedges shall be made of UV resistant thermoplastic with glass fibre (Polybutylene Terephthalate(PBT) / Polyamide( PA 06)
- iii) The loop bail / rope shall be flexible, made of stainless steel material of (AISI 304 / 301), fitted with plastic u-saddle. It shall be possible to open the bail loop in order to be put through a ring bracket or a cross arm hole. The distance between the end of U-Saddle and the cable fitment area shall be of min 400 mm, or more to ensure the min bending radius of cable while installation

#### **Raw material for Universal Pole Bracket**

Universal Pole Bracket for Anchoring Assembly shall be made out of a single piece Aluminium alloy made of gravity die casting and further heat treated to required strength. Extruded aluminium brackets are not allowed due to sharp corners. The brackets shall be suitable for attachment to a pole by one bolt or two stainless Steel straps.



## Volume- II

### **Raw material for Suspension Clamp**

- a) The body shall be made of plastic to avoid damage to the ADSS cable during pulling without liner at the time of installation. The flange shall be fitted with a non-permanent locking device to prevent any cable escape from the clamp body at the line installation, before fitting the liner. The body and Liner shall be made of weather and UV resistant Thermo plastic – Polyamide / PBT and Elastomer respectively.
- b) The Flange made of plastic shall be a part of body to lock the liner. Built- in bracket support shall be suitable for fixing to pole by means of a single SS Strap and SS Buckles or by a M14 hot dip galvanized steel bolt (as per IS: 1367 Part-13) in case of multiple runs over cross arms

### **Raw material for Adjustable Cable Storage Bracket**

Bracket and Cap made of Aluminium Alloy and other items which includes bolt, nut, washers etc., shall be of hot dip galvanised steel. Rod shall be of Aluminium / Galvanised Steel (rod/ pipe) to avoid rust and corrosion.

### **Raw material for Stainless steel Strap and Buckles**

- a) The stainless steel material of the Strap shall be of high mechanical strength, corrosion and wear resistant as per ASTM SS 202.
- b) The Buckle shall be made from ASTM SS 304 of thickness not less than 0.8 mm.

### **Raw Material for Down Lead Clamps:**

Down Lead Clamps shall be made of weather and UV resistant Thermo plastic – Polyamide / PBT

### **1.2.5. Testing of the accessories:**

Design aspect of all Accessories shall be verified as per the description. The Type Test (for product qualification) and Acceptance Test (for batch acceptance by purchaser) shall be conducted at supplier premises or any NABL or COFRAC accredited Laboratory

### **Tests for Dead End Clamp**

The following table details the Type tests and Acceptance Test for Dead End Clamp:

SI. No.	Test	Type Test	Acceptance Test
1	Visual	X	X
2	Dimensional	X	X
3	Raw material verification <sup>(1)</sup>	X	X
4	Tensile Test <sup>(2)</sup>	X	X
5	Galloping Test	X	
6	Climatic Ageing Test	X	
7	Corrosion Test	X	

(1) Raw material data Sheet and test certificate to be verified

(2) For factory acceptance test duration of the test is 10 Minutes.

### **Tensile Test:**

A minimum load value T (N) = 50% - 60% of Tensile Strength or Maximum Allowable Tension (MAT) of the cable, sustained for minimum one hour shall not damage the outer jacket of the cable such as piercing or creep. There shall be no displacement between the dead end fitting and cable. The change in attenuation of each fibre at the end of the test shall be  $\leq 0.1$  dB.

Method : IEC 60794-1-2-E1.

## Volume- II

---

### **Galloping Test:**

The Dead End Clamp under Galloping Vibration with High Amplitude and low frequency shall not rupture and damage the cable outer sheath as piercing or creep.

Method : IEEE std. 1222 – 2004

### **Climatic Ageing Test:**

The Climatic ageing test shall be conducted as per test method standard NF EN 50483-6 with the following specifications:

Test Condition:

- i) Temperature : 70°C
- ii) Clamps radially arranged, placed opposite the light source with their fitting bolt horizontal.

Requirements:

After the climatic ageing, Tensile test as per 3.1 (a) shall be repeated after 24 hours but not later than 72 hours with load values not less than 20% specified in the clause. The marking for identification of pieces shall be visible when examined with normal or rectified vision, without enlargement

Method: NF EN 50483-6

### **Corrosion Test:**

The Corrosion test shall be conducted as per standard NF EN 50483-6 with the following specifications:

Test Parameter:

- i) Gaseous atmosphere as per para 8.4.2. (test method 1)
- ii) Clamps placed in its service position

Requirements:

After the corrosion Test, Tensile test as per 3.1 (a) shall be repeated after 24 hours but not later than 72 hours with load values not less than 20% specified in the clause. There shall be no trace of rust visible on the surface of clamps

### **Tests for Universal Pole Bracket:**

The following table details the Type tests and Acceptance Test for Universal Pole Bracket.

Sl. No.	Test	Type Test	Acceptance Test
1	Visual	X	X
2	Dimensional	X	X
3	Raw material verification <sup>(1)</sup>	X	X
4	Tensile Test <sup>(2)</sup>	X	X

(1) Raw material data Sheet and test certificate to be verified

(2) For factory acceptance test duration of the test is 10 Minutes.

### **Tensile Test:**

A minimum load value  $T(N) = 3$  times the Tensile Strength of suitable cable or 15 KN whichever is lower shall not cause any breakage of pole bracket up to specified tensile strength.

### **Suspension Clamp:**

## Volume- II

The following table details the Type tests and Acceptance Test for Suspension Clamp.

Sl. No.	Test	Type Test	Acceptance Test
1	Visual	X	X
2	Dimensional	X	X
3	Raw material verification <sup>(1)</sup>	X	X
4	Tensile Test <sup>(2)</sup>	X	X
5	Slip Test	X	
6	Galloping Test	X	
7	Climatic Ageing Test	X	
8	Corrosion Test <sup>(3)</sup>	X	

(1) Raw material data Sheet and test certificate to be verified

(2) For factory acceptance test duration of the test is 10 Minutes.

(3) Not applicable for non-metallic clamps.

### Tensile Test:

A minimum load of value of T (N) = 20% rated Tensile Strength or Maximum Allowable tension (MAT) of suitable cable or 3 KN whichever is lower, sustained for minimum one minute shall not cause any breakage of clamp.

### Slip Test:

Suspension clamps shall enable the cable slip with a cable angle of 5°-8° down to the horizontal axis between a load of 100N to 200N and shall not result in any breakage of cable or collapse of pole structure.

### Galloping Test

The Suspension Clamp with the cable under the Galloping vibration with high Amplitude and low frequency shall not rupture and damage the cable outer sheath such as piercing or creep.

Method: IEEE Std. 1222 – 2004

### Climatic Ageing Test:

The Climatic ageing test shall be conducted as per test method standard NF EN 50483-6 with the following specifications:

Test Parameter:

- i) Temperature : 70°C
- ii) Clamps radially arranged, placed opposite the light source with their fitting bolt horizontal. The light source, a system with opening for introduction of cable oriented towards the opposite direction.

Requirements:

After the climatic ageing, Mechanical test as per 3.3 (a) shall be repeated after 24 hours but not later than 72 hours with load values not less than 20% specified in the clause. The marking for identification of pieces shall be visible when examined with normal or rectified vision, without enlargement.

Method: NF EN 50483-6

## Volume- II

### Corrosion Test :

The Corrosion test shall be conducted as per standard NF EN 50483-6 with the following specifications:

Test Parameter:

- i) Gaseous atmosphere as per para 8.4.2. (test method 1)
- ii) Clamps placed in its service position

Requirements:

After the corrosion Test, Tensile test as per 3.3 (a) shall be repeated after 24 hours but not later than 72 hours with load values not less than 20% specified in the clause. There shall be no trace of rust visible on the surface of clamps

### Tests for Adjustable Cable Storage Bracket

The following table details the type tests and Acceptance Test for Adjustable Cable Storage Bracket

Sl. No.	Test	Type Test	Acceptance Test
1	Visual	X	X
2	Dimensional	X	X
3	Raw material verification <sup>(1)</sup>	X	X

(1) Raw material data Sheet and test certificate to be verified

### Tests for Stainless Steel Strap and Buckle

Type tests on SS Straps and Buckles shall consist of Chemical Analysis Test Report of Composition. In addition, the SS Strap shall be tested for Tensile Strength and Ultimate Elongation.

Sl. No.	Test	Type Test	Acceptance Test
1	Visual	X	X
2	Dimensional	X	X
3	Raw material verification <sup>(1)</sup>	X	X
4	Tensile Test	X	X
5	Chemical Properties	X	

(1) Raw material data Sheet and test certificate to be verified

### Mechanical Strength Test:

One loop of SS strap with a length of 0.75 meter and strapped with a buckle shall withstand a minimum load of 7.5 KN, in order to ensure that universal pole bracket can hold the Tension / dead-end clamp.

### Tests for Down Lead Clamp

The following table details the type tests and Acceptance Test for Down Lead Clamp

Sl. No.	Test	Type Test	Acceptance Test
1	Visual	X	X
2	Dimensional	X	X

## Volume- II

---

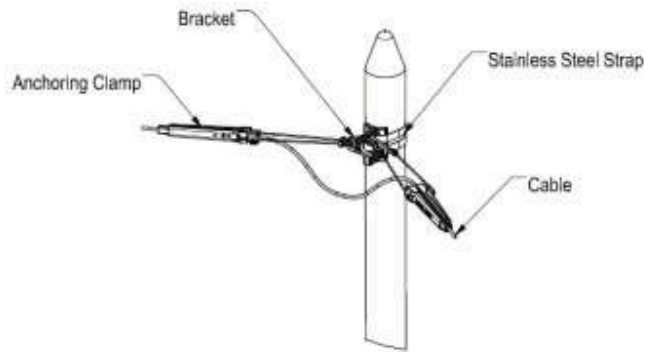
Sl. No.	Test	Type Test	Acceptance Test
3	Raw material verification(1)	X	X

Raw material data Sheet and test certificate to be verified

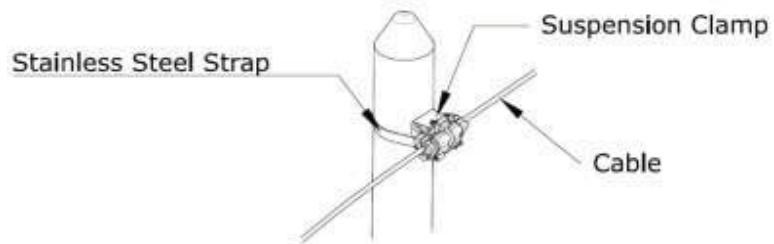
### 1.2.5. Installation Procedure for Accessories

To be specified by the Manufacturer

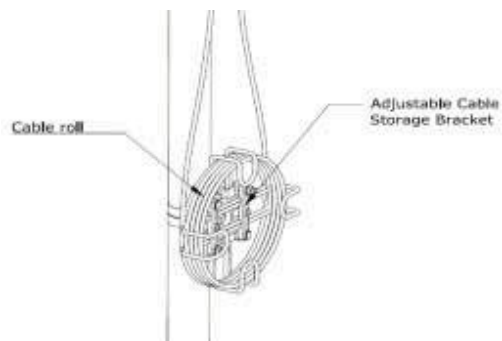
#### Tensioning (Dead End) Assembly



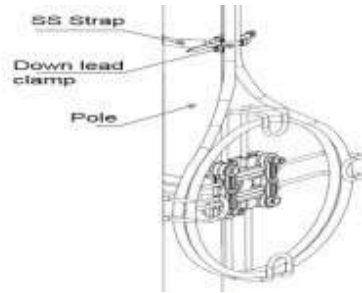
#### Suspension Clamp Assembly



#### Adjustable Cable Storage Bracket

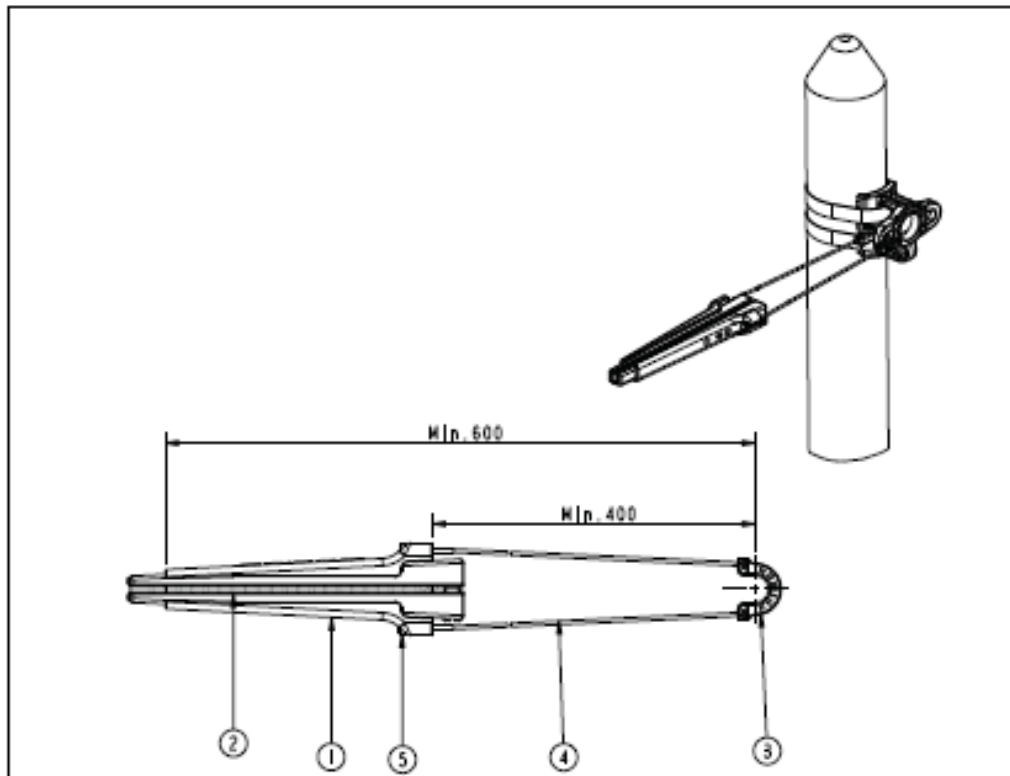


#### Down lead clamp



### 1.2.5.10. Typical Drawings of Accessories

#### Dead-End Clamp



5	2	End terminal	Aluminium Alloy
4	1	Stainless Steel Wire	Stainless Steel
3	1	U- Saddle	UV Resistant Thermo Plastic
2	1	Wedges	UV Resistant Thermo Plastic
1	1	Body	Aluminium Alloy/Thermo Plastic
REP	QTY	DESCRIPTION	MATERIAL

ANCHORING ( DEAD END ) ASSEMBLY

MATERIAL: See Table		
ALL DIMENSIONS IN MM		PART NO.:
		DRG NO.:



**Universal Pole Bracket**


NOTE:-  
 MATERIAL : ALUMINIUM ALLOY  
 MINIMUM BREAKING LOAD : 15KN

Min 114

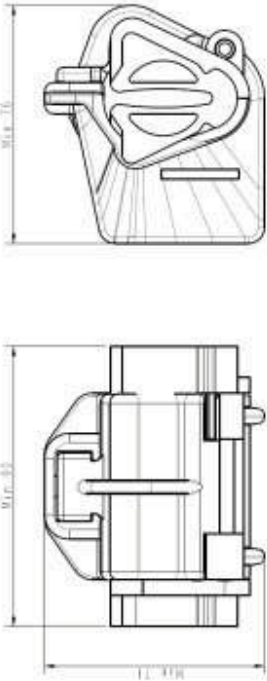
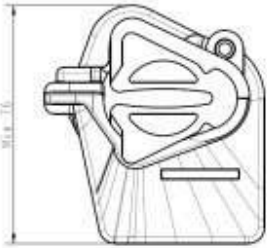
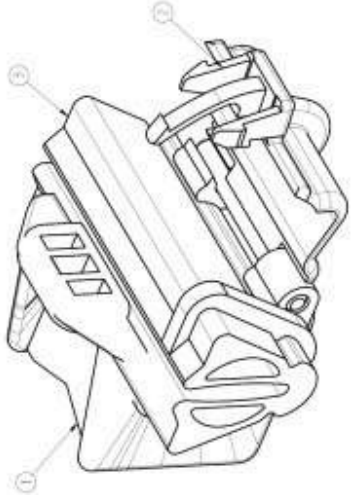
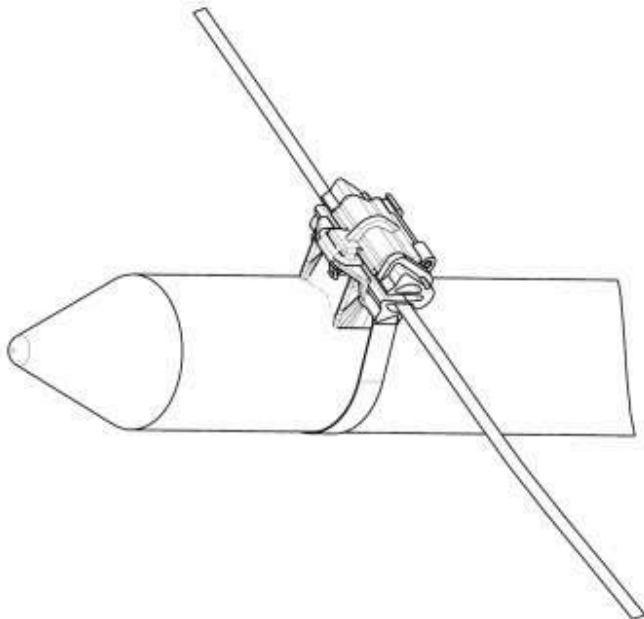






Min 64

Min 89

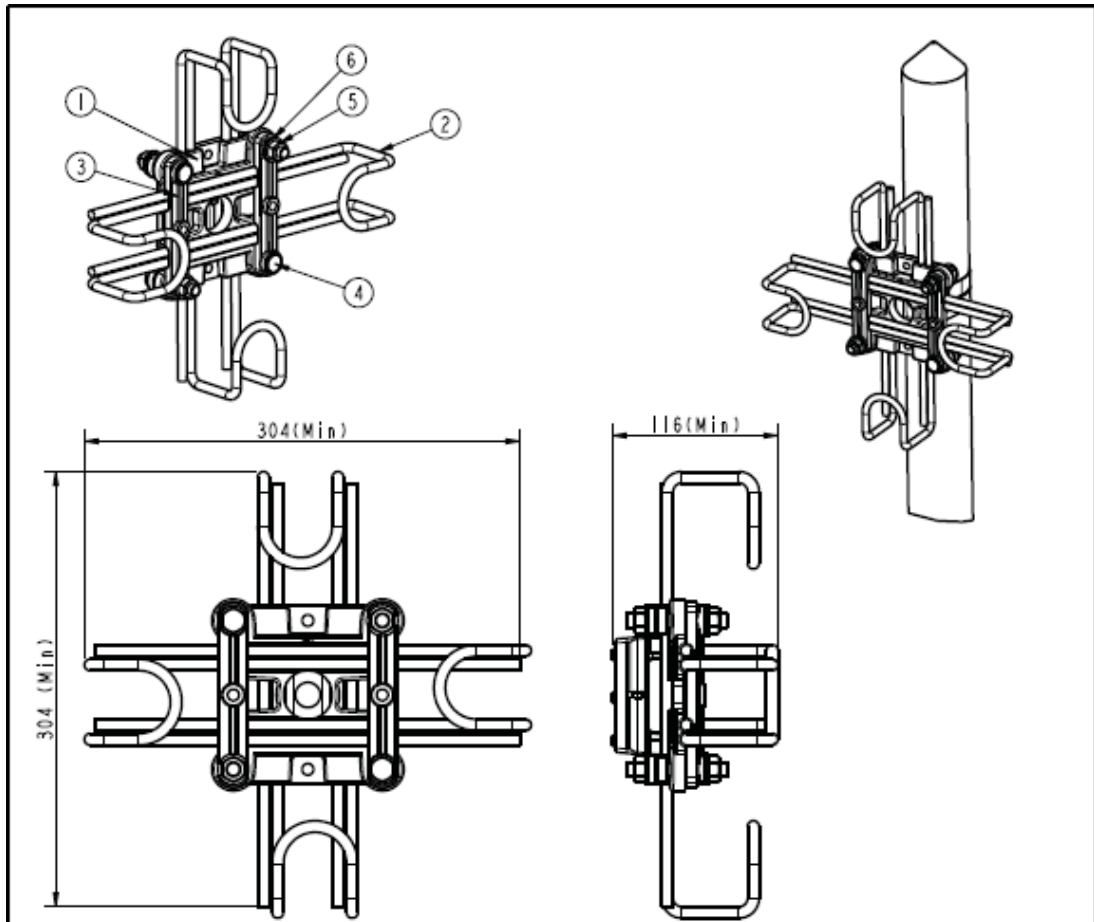
**UNIVERSAL POLE BRACKET**

MATERIAL: REFER NOTE		
ALL DIMENSIONS IN MM		PART NO
		DRG NO.

**Suspension Clamp Assembly**

<p>SUSPENSION ASSEMBLY NOTE: MATERIAL : SEE TABLE</p> <table border="1" style="width: 100%; border-collapse: collapse; margin-bottom: 10px;"> <thead> <tr> <th style="width: 5%;">S. No.</th> <th style="width: 15%;">QTY</th> <th style="width: 40%;">DESCRIPTION</th> <th style="width: 40%;">MATERIAL</th> </tr> </thead> <tbody> <tr> <td>1</td> <td>1</td> <td>LINED</td> <td>THERMO PLASTIC ELASTOMER</td> </tr> <tr> <td>2</td> <td>1</td> <td>FLANGE</td> <td>UP RESISTANT THERMO PLASTIC</td> </tr> <tr> <td>3</td> <td>1</td> <td>WOOD</td> <td>UP RESISTANT THERMO PLASTIC</td> </tr> </tbody> </table> <div style="display: flex; justify-content: space-around;"> <div style="text-align: center;">  <p>Max. 30</p> <p>11.00</p> </div> <div style="text-align: center;">  <p>Max. 30</p> </div> </div> <div style="text-align: center; margin-top: 20px;">  </div>	S. No.	QTY	DESCRIPTION	MATERIAL	1	1	LINED	THERMO PLASTIC ELASTOMER	2	1	FLANGE	UP RESISTANT THERMO PLASTIC	3	1	WOOD	UP RESISTANT THERMO PLASTIC	<div style="text-align: center; margin-bottom: 20px;">  </div> <p style="text-align: center; font-weight: bold;">SUSPENSION CLAMP ASSEMBLY</p> <table border="1" style="width: 100%; border-collapse: collapse;"> <tr> <td style="width: 50%;"></td> <td style="width: 50%; text-align: center;">  </td> </tr> <tr> <td colspan="2" style="text-align: center;">  </td> </tr> </table>				
S. No.	QTY	DESCRIPTION	MATERIAL																		
1	1	LINED	THERMO PLASTIC ELASTOMER																		
2	1	FLANGE	UP RESISTANT THERMO PLASTIC																		
3	1	WOOD	UP RESISTANT THERMO PLASTIC																		
																					
																					

**Adjustable Cable Storage Bracket**



Note:  
Weight: 2 Kg (Approx)

6	4	M10 - Washer	Galvanised Steel
5	4	M10 - Nut	Galvanised Steel
4	4	M10 - Bolt	Galvanised Steel
3	4	CAP	Aluminium Alloy
2	4	ROD	Aluminium Alloy/ Galvanised Steel
1	1	Bracket	Aluminium Alloy
Rep	QTY	Description	Material

**ADJUSTABLE CABLE STORAGE BRACKET**

MATERIAL: See Table		
		PART NO.:
ALL DIMENSIONS IN MM		DRG NO.:

**SS Strap and Buckles**

**STRAP: - IF 207**

**NOTE :-**  
 THICKNESS = 0.7 ± 0.05  
 TENSILE STRENGTH = 7.5KN Minimum  
 ELONGATION = 30% MIN FINISH = 2B  
 MATERIAL = SS 302  
 RAW MATERIAL (COMPOSITION) TOLERANCE = AS PER ASTM 'A 480'

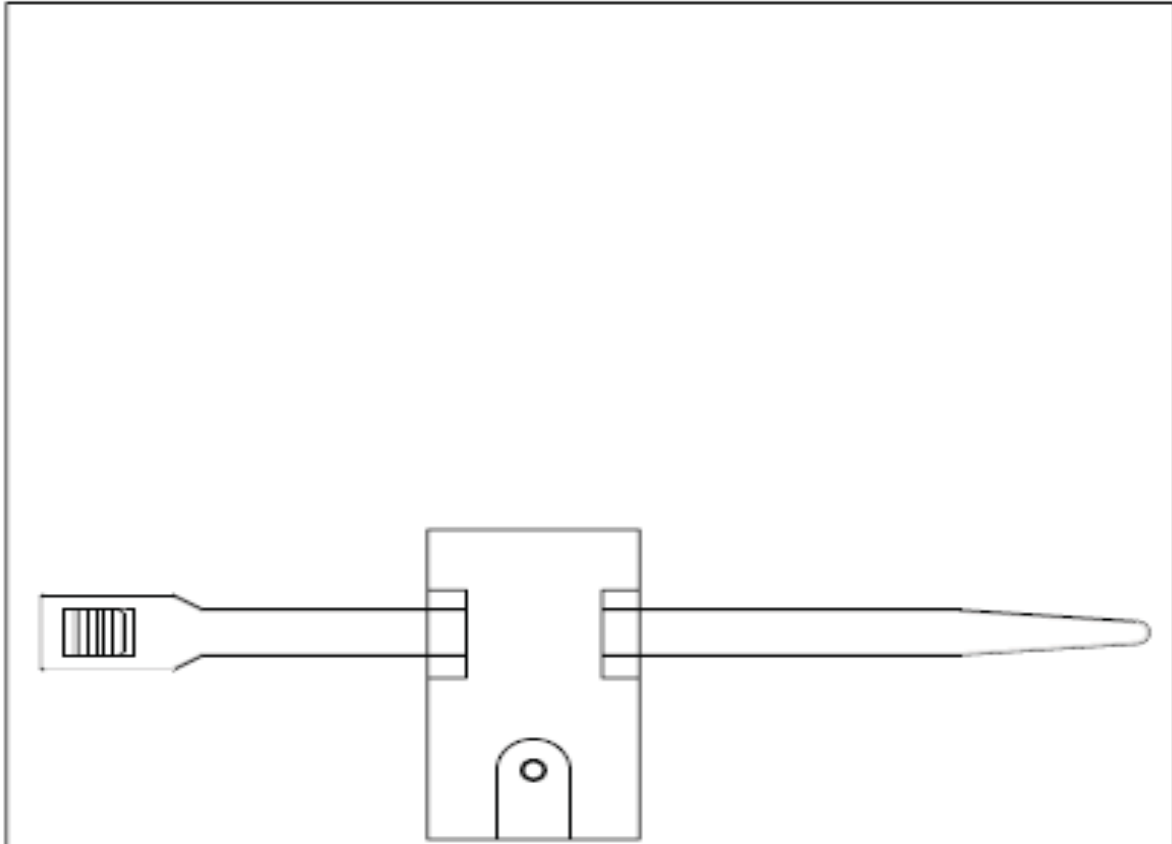
**BUCKLE:- CF 20**

**NOTE :-**  
 MATERIAL = SS 304  
 RAW MATERIAL TOLERANCE = AS PER ASTM 'A 480'  
 QUANTITY PER STANDARD BOX = 100 nos.

**STANDARD CASING:-**

Sl.No	Description	Qty	Material
1	S.S STRAP CASING	1	Thermo Plastic
2	S.S STRAP BOBIN	1	Thermo Plastic
3	S.S STRAP	50 M	SS 202

**Down Lead Clamp**



Material: UV Protected Thermo Plastic

<b>DOWNLEAD CLAMP</b>		
DE DOKUMENT EN LAAT NIETS DE PROPERE INTELLECTUELE OF Y GENT ATTACHED OOR NIETRE INSPERITE. D. VELD EET NIET A TIJDE CONFIDENTIËL. DE PAST ETOE NIETRE, COMPANIE ETOE NIETRE (ETC.) NIETRE NIETRE NIETRE NIETRE. THIS DOCUMENT INCLUDING ALL INTELLECTUAL PROPERTY RIGHTS RESERVED THEREWITH ARE OUR OWNERSHIP. IT IS GIVEN TO YOU ON A CONFIDENTIAL BASIS AND CANNOT BE COPIED, REPRODUCED, COMMUNICATED AND/OR ADAPTED (IN ANY MANNER) WITHOUT OUR PRIOR WRITTEN APPROVAL.		
	MATERIAL: Refer Note	
	ALL DIMENSIONS IN MM	PART NO.:
		DRG NO.:

**1.2.5.11. Quality Requirements**

- ξ The design, construction and fabrication of each accessories and fixtures shall be inherently robust and rigid and shall be as per the drawings given in the specifications.

## Volume- II

---

- § Dimensions and weight of each accessory and fixture shall be specified by the manufacturer, wherever applicable  
Each accessory and fixture shall be manufactured in accordance with the international quality standards ISO 9001-2008 (latest issue) for which the manufacturer should be duly accredited. The Quality Manual shall be submitted by the manufacturer.
- § The accessories and fixtures shall be of good quality and superb finish
- § The composition of the material used in manufacturing accessories and fixtures shall be indicated.
- § In case of rods and wires, no joint shall be permitted except those in the base rod or wire before final drawing of rods.
- § The manufacturer shall possess the manufacturing and test facilities to test accessories and fixtures as per specifications
- § Parts of the fittings made of mild steel and/or carbon steel shall be manufactured as per IS: 2062 and or/IS 2004-9 and to be hot dip galvanized as per IS 2629
- § Aluminum alloy wire, aluminized steel, galvanized mild steel, carbon steel(as per IS standards), having required mechanical strength, corrosion resistance and formability, depending on the types of applications, shall be employed in manufacturing of the fitting.
- § All insulating/plastic rubber parts shall be made of UV resistant material
- § Aluminum components shall be of casted parts and no extruded parts are to be used to avoid sharp edges

### 1.2.5.12. Documentation

- § Complete technical literature in English with detailed cable construction diagram of various sub-components with dimensions, weight & test data and other details of the cable shall be provided.
- § All aspects of installation, operation, maintenance and fibre splicing shall also be covered in the handbook. The pictorial diagrams of the accessories (with model no. and manufacturer name) supplied along with the cable as package shall be also be submitted. A hard as well as soft copy of the technical as well as installation manuals shall be provided.

### 1.2.5.13. Packing

The packing of accessories shall carry the following information:-

- § Name of the product, manufacturer's model, and serial number
- § Manufacturer's name and trade mark
- § Type, diameter, of the optical fibre cable
- § Type of accessories & fixture and its code number
- § Batch number, date, month and year of production
- § Any other necessary marking

### 1.2.5.14. Marking

Following Mandatory marking shall be available on each installation Accessories including SS Strap:

- § Manufacturer's name or logo or trade name
- § Month and year of manufacturing
- § Product Reference

**1.2.6 Aerial Drop Cable - 4F**

SL No.	Parameter	Design Specification
1.	Optical Fibre	As per ITU-T Rec. G 657 A1
2.	Type of fibre (wavelength band optimized nominal 1310 nm)	Single mode (Section I (Type V) of TEC GR No: TEC/GR/TX/ORM-01/04/SEP-09 and subsequent amendments, if any)
3.	TEC Compliant	TEC/GR/TX/OFC-024/01/Mar-2015
<b>Geometrical Characteristics</b>		
4.	Mode Field Diameter for matched clad	8.2 to 9.4 $\mu\text{m}$
5.	Cladding Diameter	125.0 $\mu\text{m} \pm 0.7 \mu\text{m}$
6.	Cladding non-circularity	$\leq 0.8\%$
7.	Core Clad concentricity error	$\leq 0.5\mu\text{m}$
8.	Diameter Over Primary Coated with double UV cured acrylate (shall be measured on un-coloured fibre)	245 $\pm$ 10 $\mu\text{m}$ <i>Thickness of the coating may be over and above the values specified above, if the manufacturer adopts separate UV cured colouring process (to colour the un-coloured fibres) other than the line integrated colouring process (of secondary layer of primary coating) of the fibres, during fibre manufacturing.</i>
9.	Coating/Cladding Concentricity	$\leq 12 \mu\text{m}$
<b>Transmission Characteristics</b>		
10.	Fibre Attenuation before Cabling	@ 1310 nm : $\leq 0.34 \text{ dB/km}$ Between 1285 and 1360 nm : $\leq 0.37 \text{ dB/km}$ Between 1360 and 1480 nm : $\leq$ Value at 1310 nm Between 1480 and 1525 nm : $\leq 0.34 \text{ dB/km}$ @ 1550 nm : $\leq 0.21 \text{ dB/km}$ Between 1525 and 1625 nm : $\leq 0.24 \text{ dB/km}$ @ 1270 nm : $\leq 0.40 \text{ dB/km}$ @ 1490 nm : $\leq 0.24 \text{ dB/km}$ @ 1625 nm : $\leq 0.23 \text{ dB/km}$
11.	Fibre Attenuation after Cabling	@ 1310 nm : $\leq 0.36 \text{ dB/km}$ @ 1550 nm : $\leq 0.23 \text{ dB/km}$ @ 1490 nm : $\leq 0.26 \text{ dB/km}$
<b>Dispersion</b>		
12.	Total Dispersion	In 1285-1330 nm band: $\leq 3.5 \text{ ps}/(\text{nm} \times \text{km})$ In 1270-1340 nm band: $\leq 5.3 \text{ ps}/(\text{nm} \times \text{km})$ @1550 nm : $\leq 18 \text{ ps}/(\text{nm} \times \text{km})$ @1625 nm : $\leq 22 \text{ ps}/(\text{nm} \times \text{km})$ <i>The total dispersion in the 1250-1625nm band shall be measured at an interval of 10nm and the test results shall be submitted.</i>
13.	Polarization Mode Dispersion at 1310nm & 1550 nm	Fibre: $\leq 0.2 \text{ ps}/\sqrt{\text{Km}}$ Cabled Fibre: $\leq 0.3 \text{ ps}/\sqrt{\text{Km}}$ Link Design Value: $\leq 0.2 \text{ ps}/\sqrt{\text{Km}}$ <i>Measurement on un-cabled fibre may be used to generate cabled fibre statistics and correlation is established.</i>

## Volume- II

SL No.	Parameter	Design Specification
14.	Zero Dispersion Wavelength	1300 to 1324 nm
15.	Zero Dispersion Slope	$\leq 0.092 \text{ ps}/(\text{nm}^2 \times \text{km})$
16.	Fibre Cut-off Wavelength	1320 nm Max
17.	Cable Cut-off Wavelength	1260 nm Max
<b>Mechanical Characteristics</b>		
18.	Proof Test for minimum strain level (Test method IEC 60793-1-30)	1%
19.	Peak Stripability force to remove primary coating of the fibre (Test Method IEC 60793-1-32)	$1.3 \leq F \leq 8.9 \text{ N}$ <i>The force required to remove 30 mm <math>\pm</math> 3 mm of the fibre coating shall not exceed 8.9N and shall not be less than 1.3N</i>
20.	Dynamic Tensile Strength (Test Method IEC 60793-1-31)	$\geq 550 \text{ KPSI (3.80 GPa)}$ for Un-aged $\geq 440 \text{ KPSI (3.00 GPa)}$ for Aged
21.	Dynamic Fatigue (Test Method IEC 60793-1-33)	$\geq 20$
22.	Static Fatigue (Test Method IEC 60793-1-33)	$\geq 20$
23.	Fibre Micro Bend (Test Method FOTP-62/IEC 60793-1-47)	
A	Change in attenuation when fibre is coiled with 10 turns on 15 mm radius mandrel	$\delta 0.25 \text{ dB}$ at 1550nm $\delta 1.0 \text{ dB}$ at 1625nm
B	Change in attenuation when fibre is coiled with 1 turn around 10 mm radius mandrel	$\delta 0.75 \text{ dB}$ at 1550nm $\delta 1.5 \text{ dB}$ at 1625nm
24.	Fibre Curl (Test Method IEC 60793-1-34)	$\geq 4$ meter radius of curvature
<b>Environment Characteristics</b>		
25.	Operating Temperature (Test Method IEC 60793-1-52) Temperature Dependence of Attenuation: Induced Attenuation at 1550 nm at -60 °C to +85 °C:	-60 °C to +85 °C $\leq 0.05 \text{ dB/km}$
26.	Temperature – Humidity Cycling (Test Method EIA/TIA-455-73) Induced Attenuation at 1550 nm at -10 °C to +85 °C	$\leq 0.05 \text{ dB/km}$ and 95% relative humidity
27.	Water Immersion 23 °C (Test Method IEC 60793-1-53) Induced Attenuation at 1550 nm due to Water Immersion at $23 \pm 2^\circ\text{C}$	$\leq 0.05 \text{ dB/km}$
28.	Accelerated Aging (Temperature) 85°C (Test Method IEC 60793-1-51) Induced Attenuation at 1550 nm due to Temperature Aging at $85 \pm 2^\circ\text{C}$	$\leq 0.05 \text{ dB/km}$
29.	Retention of Coating Colour (Test method IEC- 60793 – 1 - 51) Coated Fibre shall show no discernible change in colour, when aged for relative humidity	30 days at 85°C with 95% Humidity and then 20 days in 85°C dry heat
<b>Installation and Operation Condition</b>		
30.	Max Span length	100m



## Volume- II

SL No.	Parameter	Design Specification		
31.	Max Ice loading	Nil		
32.	Operational Wind Velocity	75 Kmph		
33.	Sag of span length	§ Max sag allowed without excess load: 1% of span length § Max sag allowed with excess load: 2% of span length		
34.	Temperature Range	§ Operation: -20 to +70 degrees C § Installation: -15 to +70 degree C § Storage & transport: -20 to +70 degrees C		
OFC Construction Details				
35.	4F	No.	Colour Schema	
		Fibre per tube	4	BL,OR,GR, BR
		No. of Loose tube	1	Natural
		<i>(Type approval for a cable shall be based on the no. of fibres in the cable)</i>		
36.	Tensile force design parameter	9.81 x 2.5 x W or 1000 N whichever is higher (W is the mass of 1 Km length of the cable in Kg)		
37.	Loose Tube ID/OD	1.4 ± 0.1 / 2.0 ± 0.1 mm		
38.	Loose Tube Material	PBT		
39.	Embedded Strength Material	FRP/ARP		
40.	Diameter of FRP	1.0 + 0.1 mm		
41.	Aramid Yarns (Peripheral Strength Member)	3.9 ± 0.4 Kg/Km		
42.	Sheath Material	UV Proof HDPE		
43.	Sheath Colour	Black with white stripes		
44.	Min. Thickness of Sheath Material	1.8 mm		
45.	Cable Weight	38 ± 10%		
46.	Cable Diameter	6.5 ± 0.5 mm		
Fibre Material Properties				
47.	Substances of which fibre are made of	To be indicated by the manufacturer		
48.	Protective material requirement			
i	The physical and chemical properties of the material used for the fibre primary coating	It shall meet the requirement of fibre		
ii	Coating and for single jacket fibre	As per Stripping force mentioned in the specifications		
49.	The best way of removing protective coating material.	To be indicated by the manufacturer		

## Volume- II

SL No.	Parameter	Design Specification
50.	Group refractive Index of fibre	To be indicated by the manufacturer

Table 60: Specifications for Aerial drop cable

### Note:

- Attenuation in the band 1380-1390 nm shall be checked at every 2nm after Hydrogen ageing as per IEC 60793-2-50. Hydrogen ageing test is to be carried out by CACT, Bangalore or any other recognized laboratory for type test.
- Sudden irregularity in attenuation shall be less than 0.1 dB
- The spectral attenuation shall be measured on un-cabled fibre.
- The Spectral attenuation in the 1250 nm–1625 nm band shall be measured at an interval of 10nm and the test results shall be submitted.

### 1.2.6. Other Standards

Sl. No.	Document No.	Title/Document Name
1.	GR No. GR/OFT-01/03. APR 2006	Tools for installation & Operating the OFC & for assembly of the OF Splice Closures.
2.	GR No. TEC/GR/TX/ORM-01/04 SEP.09	Specification for Raw Material used in manufacturing of OF Cables.
3.	GR No. G/CBD-01/02. NOV 94	Drum specifications for Cable ends.
4.	SD: QM 333 (Mar 2010)	Standard for Environmental testing of Telecommunication equipment
5.	GR-20-CORE Issue4, 2013	Generic Requirement for Optical Fibre Cable (Bell Core)
6.	IEC – 60793-1	Test Method for optical fibres
7.	IEC 811-5-1, IEC 794-1-2-E1 IEC 794-1-2-E2, IEC 794-1-2-E3 IEC 794-1-2-E4, IEC 794-1-2-E7, IEC 794-1-2-E10, IEC 794-1-E11 IEC 794-1-2-F1, IEC 794-1-2-F3, IEC 794-1-2-F5	Test Methods for Optical Fibres
8.	EIA 359-A & IEC Publication 304(4)	Colour Standard
9.	EIA 455-104, EIA/TIA-455-181, EIA/TIA-455-37	Test Methods
10.	ISO 175, ISO 9001-2008	Test Methods for Optical Fibres International Quality Management System

Table 61: Other Standards for Aerial Drop Cable

### 1.2.6. Functional Requirements

- § The design and construction of Optical fibre cable shall be inherently robust and rigid under all conditions of installation, operation, adjustment, replacement, storage and transport.
- § The Optical fibre cable shall be able to work in a saline atmosphere in coastal areas and should be protected against corrosion.
- § Life of cable shall be at least 25 years. Necessary statistical calculations shall be submitted by the manufacturer, based upon life of the fibre and other component parts of the cable. The cable shall meet the cable aging test requirement.
- § It shall be possible to operate and handle the Optical fibre cable with tools as per GR No. GR/OFT-01/03 APR 2006 and subsequent amendment, if any. If any special tool is required for operating and handling the optical fibre cable the same shall be provided along with the cable.
- § The Optical fibre cable supplied shall be suitable and compatible to match with the dimensions, fixing, terminating & splicing arrangement of the splice closure. The cable supplied shall also meet other

## Volume- II

---

requirement of splice closure (GR No. TEC/GR/TX/OJC-002/03/APR-2010) and subsequent amendments, if any.

- ξ The manufacturer shall submit an undertaking that the optical and mechanical fibre characteristics shall not change during the lifetime of the cable against the manufacturing defects.
- ξ It is mandatory that the Optical fibre cable supplied in a particular route is manufactured from a single source of optical fibres.

### 1.2.6. Colour Qualification and Primary coating Test

#### Colour Qualification Test:

- a) MEK Rub Test (Methyl Ethyl Ketone Test):

To be tested by using soaked (Solvent) tissue paper for ten strokes unidirectional on 10 cm length of fibre. No colour traces shall be observed on the tissue paper after testing.

- b) Water immersion Test (Type Test):

To be tested for coloured fibre for 30 days. After the test Colour qualification, Attenuation measurement & Strippability test are to be taken.

#### Primary coating Test:

- a) Fourier Transform Infrared Spectroscopy (FTIR) Test:

To be tested to check the curing level of coating on the surface of natural fibre. The curing level shall be better than 90%.

- b) Adhesion Test:

To be tested by using soaked (Solvent) tissue paper for ten strokes unidirectional on 10 cm length of fibre. No coating shall be observed on the tissue paper after testing.

### 1.2.6. OFC Construction Specifications

The Optical Fibre Cable shall be designed to the parameters mentioned in the specifications. The manufacturer shall submit designed calculations and the same shall be studied and checked.

1. **Secondary Protection:** Primary coated coloured fibres may be protected by loose packaging within tube, which shall be filled with thixotropic jelly. The dimensions of tube shall be as per specifications
2. **Reinforcement:** Cable shall be reinforced with aramid yarn in the periphery over the loose tube. The aramid yarn shall be uniformly and equally distributed on the entire periphery (circumference) of the buffer tube. The quantity of the aramid yarn used per kilometer length of the cable shall be as per the specifications mentioned.
3. **Filling compound:** Filling compound used in the buffer tube shall be compatible to fibre, secondary protection of fibre. The drip point shall not be lower than +70°C. The fibre movement shall not be constrained by stickiness & shall be removable easily for splicing. The test method to measure drop point shall be as per ASTM D 566. The filling jelly shall be as per the GR No. TEC/GR/TX/ORM-01/04/SEP-09 and subsequent amendment issued, if any.
4. **Outer Jacket:** Circular and uniform tough weather resistant UV stabilized polyethylene compound (HDPE) material sheath/jacket, black in colour with white stripes, shall be provided over and above the reinforcement of aramid yarn. The thickness of the outer sheath/jacket shall be minimum 1.8 mm. The outer sheath shall be free from pin holes, joints, scratches, mended pieces and other defects, etc and it shall have a smooth finish.

**Note:** HDPE material (black in colour) from finished cable, shall be subjected to following tests (on sample basis) and shall confirm to the requirement of the material as per the GR no. TEC/GR/TX/ORM-01/04/SEP-09:

- ix) Density
- x) Melt flow index
- xi) Carbon black content
- xii) Carbon black dispersion

- xiii) ESCR
  - xiv) Moisture content
  - xv) Tensile strength and elongation at break
5. **Strength Member(Embedded)** / ARP non-metallic strength member embedded into the outer jacket. The strength member in the cable shall be for strength and flexibility of the cable and shall have anti buckling properties. This shall also keep fibre strain within permissible values.

### 1.2.6. Mechanical Characteristics and Tests on Optical Fibre Cable

1. Tensile strength Test:

A load of value  $T(N) = 9.81 \times 2.5W$  (where W is the mass of 1 Km of cable in 1 Kg) or 1000N whichever is higher on the cable sustained for 10 minutes shall not produce a strain of 0.25% in the fibre and shall not cause any permanent physical and optical damage to the cable. The change in attenuation of each fibre after the test shall be  $\leq 0.05$  dB both for 1310 nm and 1550 nm wavelength.

**Method:** EC 60794-1-2-E1.

2. Abrasion Test:

The cable surface shall be abraded for 100 cycles with needle (wt. 150 gm) having diameter of 1 mm with 500 grams eight (Total weight more than equal 650 gms.) for 1 minute shall not cause any perforation and loss of legibility of the marking on the sheath.

**Method:** EC-60794-1-2-E2 or by any other international test method

3. Crush Test (Compressive Test):

A compressive load of 2000 Newton applied between the plates of dimension 100 x 100 mm for 60 seconds shall not damage the cable. The change in attenuation of the fibre after the test shall be  $\leq 0.05$  dB both for 1310 nm and 1550 nm wavelength.

**Method:** EC 60794-1-2-E3.

4. Impact Test:

Impact caused by a mass weight of 25 Newton, dropped 10 times from a height of 0.5m on the surface of radius 300mm shall be withstood by cable. The change in attenuation of the fibre after the test shall be  $\leq 0.05$ dB both for 1310 nm and 1550 nm wavelength.

**Method:** EC 60794-1-2-E4.

5. Repeated Bending:

<b>Parameters:</b>	
Weight	5 Kg
Length of the cable sample	5 M (minimum)
Minimum distance from Pulley centre to holding device	216mm
Minimum distance from Wt. to Pulley centre	457mm
Pulley Diameter	20 D (D - cable diameter)
Angle of Turning	90 degrees
No. of cycles	30
Time Required for 30 cycles	2 min

The fibre shall not break during repeated bending of the cable. The change in attenuation of each fibre after the test shall be  $\leq 0.05$  dB both for 1310 nm and 1550 nm wavelength.

## Volume- II

---

### **Method**IA-455-104.

#### 6. Torsion Test:

The length of the specimen under test shall be 2 meters and the load shall be 100 N. The cable shall withstand 10 such complete cycles. The cable shall be examined physically for any cracks or tearing on the outer sheath. The fibres and other component part of the cable shall not be damaged. The change in attenuation of the fibre after the test shall be  $\leq 0.05$  dB both for 1310 nm and 1550 nm wavelength.

### **Method**EC 60794-1-2-E7.

#### 7. Kink Test:

The sample length shall be 10 times the minimum bending radius and the minimum bending radius of the cable shall be 20D (D- diameter of the cable). The loop to the minimum bend radius shall not form any kink on the cable. The change in attenuation of the fibre after test shall be  $\leq 0.05$  dB both for 1310 nm & 1550 nm wavelength.

### **Method**EC 60794-1-2-E10.

#### 8. Cable Bend Test:

The cable shall withstand repeated flexing when fibre wrapped and unwrapped 4 complete turns of 10 complete cycles around a mandrel of 20 D, where D is the diameter of the cable. There shall be no on the outer sheath of the cable. The change in attenuation of the fibre after the test shall be  $\leq 0.05$  dB both for 1310 nm and 1550 nm wavelength.

### **Method**EC 60794-1-2-E11 (Procedure-I).

#### 9. Snatch Test

<b>Parameters:</b>	
Length of the cable sample	4.5 Metres
Sag	300 mm
Testing load	300 N
Radius of impacting surface	12.5 mm
Height	100 mm
No. of times	10

There shall be no permanent physical damage to the cable. The change in attenuation of the fibre under test shall be  $\leq 0.05$  dB for 1310 nm and 1550 nm wave length.

### **Method**EC 60794-1-E9

#### 10. Cable Bend Test

<b>Parameters:</b>	
Test Temperature	20 deg. C to +70 deg. C
Mandrel Diameter	20D (D-diameter)
No. of turns	4
Conditioning time duration	24 hours at each temperature.

There shall be no permanent physical damage to the cable. The change in attenuation of the fibre under test shall be  $\leq 0.05$  dB for 1310 nm and 1550 nm wave length.

### **Method**IA RS-455-37

## Volume- II

### 11. Temperature Cycling:

<b>Parameters:</b>	
Standard Cable length of drum	4 Km/2 Km + 5%
Temperature Range for storage	20 deg. C
Temperature range for operation	-40 deg. C to +70 deg. C
Rate of change of temperature	1 deg. Per minute
	12 hrs each at temp. given below. TA2 temp.: -20°C TAt temp.: -10°C. TB1 temp.: + 60°C. TB2 temp.: + 70°C.
Temperature cycling	
No. of temperature cycles	2

The change in attenuation of the fibre under test shall be  $\leq 0.05$  dB for 1310 nm and 1550 nm wave length respectively for the entire range of temperature.

#### **Method** EC 60794-1-2-F1

### 12. Cable aging Test (Type Test):

After temperature cycle test, the cable shall be exposed to  $85 \pm 2$  degree C for 168 hours. The change in attenuation of each fibre after the test shall be  $\leq 0.05$  dB at 1310 and 1550 nm. The attenuation measurement of the test cable after stabilization at ambient temperature for 24 hours. The attenuation changes are to be calculated with respect to the base line attenuation values measured at room temperature before temperature cycling.

### 13. Water Penetration Test (Type Test):

A circumferential portion of the cable end(loose tube) shall be supported horizontally facing one metre water head, containing sufficient quantity of water soluble fluorescent dye for 7 days at ambient temperature. No dye shall be detected at the end of the 3m cable length when examined with ultraviolet light detector.

#### **Method** EC 60794-1-2-F5(fig. B) 1999

### 14. Test of Figure of 8 (Eight) on the cable (Type Test):

It shall be possible to make figure of 8 of minimum 1000 meters of the cable uncoiled from the cable reel without any difficulty. The diameter of each loop of the figure of 8 shall be maximum 2 meters. No visible damage shall occur.

### 15. Flexural Rigidity Test on the optical fibre cable (Type Test):

Test Specs: The cable shall withstand the Flexural Rigidity Test as per the test method and there shall be no cracks visible to the naked eye on the sheath of the cable. The change in attenuation of the fibre after the test shall be  $< 0.05$  dB at 1310nm and 1550nm wavelengths.

#### **Method** ASTM D -790

### 16. Cable Jacket Yield Strength and Ultimate Elongation:

## Volume- II

The aged sample taken from a completed cable conditioned at  $100 \pm 2^\circ\text{C}$  for 120 hours before testing before

Jacket Material	Minimum Yield Strength		Minimum Elongation (%)
	(MPa)	(psi)	
HDPE un-aged	16.5	2400	400
HDPE aged	12.4	1800	375

testing at cross-head speed of 50 mm per minute.

**Method** FOTP-89 or ASTM 1248 Type III class

### 17. Drip test on the cable

<b>Parameters:</b>	
Length of the Cable sample	30 cm
Length of the open end of cable sample	5 cm
Temperature	+70 deg. C
Period	24 hours

Objective: The purpose of this test is to determine the ability of jelly in the O.F. cable to withstand a temperature of 70 degree C.

The cable sample shall be of 30 cm. length of the cable with one end sealed. Outer sheath, aramid yarn, and FRP shall be removed for 5 cm from the open end of sample. The paper placed below the cable sample, kept vertically inside the oven for 24 hours at 70 deg. C shall be examined for dripping of the jelly after 24 hours and there shall be no jelly drip or oily impression on the paper.

### 18. ESCR ( Environment Stress Cracking Resistance) Test:

The outer sheath of the optical fibre cable shall be checked and tested for ESCR. There shall not be any visible cracks on the surface of the outer sheath, when examined with the help of a magnifying glass at the end of 48 hours in a 10% Igepal solution.

**Method** ASTM D-1693

### 19. UV Radiation Test:

<b>Parameters:</b>	
Type of lamp	40 Watt UV-B lamp with a peak emission at 313 nm
Duration	2000 hours

There shall be no fading or change in the colour of the markings and that of outer sheath.

**Method** ASTM G-53-96 (ASTM G-154)

### 20. Check of the quality of the loose tube (containing optical fibre):

a. Embrittlement Test of loose tube

<b>Parameters:</b>	
Minimum length of sample	85 mm
Outside diameter of the tube	$\leq 2.5$ mm
Speed of movable jaw	50 mm per minute

## Volume- II

Safe bend diameter of tube	15D (d-outside diameter of loose tube)
----------------------------	--

The minimum length of the test sample depends on the outside diameter of the loose tube and shall be 85 mm for tubes up to 2.5 mm outside dia. The length of the bigger tubes should be calculated by using the following equation:

$$L_o > 100 \times \sqrt{[(D_2 + d_2)]/4}$$
 where

$L_o$  = Length of tube under test.

$D$  = Outside dia of loose tube.

$d$  = Inside dia of loose tube.

The tube shall not get embrittled. No ink should appear on the tube up to 15 D, where D is the outside diameter of the loose tube. There shall also not be any physical damage or mark on the tube surface.

### b. Kink Resistance Test on the Loose Tube

<b>Parameters:</b>	
Tube sample	Loose tube with fibre & gel
Min bend radius of tube	15D (d-outside diameter of loose tube)
No. of times	4

No damage or kink should appear on the surface of the tube.

### 21. Drainage Test for loose tube:

<b>Parameters:</b>	
Sample size	30 cm tube length
Tube in horizontal position	24 hrs. at ambient temperature
Tube in vertical position	24 hrs at 70 deg. C

There shall be no oil or gel in the breaker

### 22. Check of easy removal of sheath:

300 mm sheath shall be removed easily by using removal tool and no undue extra force is applied to remove the sheath. No component part of the cable shall be damaged.

### 23. Check of the effect of aggressive media on the cable

<b>Parameters:</b>	
Aggressive media solution	PH – 4 & PH -10
Length of the sample of finished cable	600 mm
Duration of test	30 days

Effect of aggressive media shall be checked by the solution of PH4 and PH10 on test samples of the finished cable, each of 600 mm in length with sealed ends for 30 days. There shall be no corrosion on the sheath and other markings of the cable.

### Method SO 175

## 1.2.6.6 Cable Marking

- ξ A long lasting suitable marking shall be applied in order to identify this cable from other cables. The cable marking shall be imprinted (indented). The marking on the cable shall be indelible of durable quality and at regular intervals of one meter length. Alternatively, permanent printing with laser shall also be acceptable.



## Volume- II

---

In case of laser printing method, the impression shall not exceed, the depth of 0.15mm. The accuracy of the sequential marking must be within -0.25% to +0.5% of the actual measured length. The markings on the cable must not rub off during normal installation and in life time of optical fibre cable.

§ The marking shall be in contrast colour(white) over the black HDPE Sheath (jacket) and shall be one by hot foil indentation method. The colour used must withstand the environmental influences experienced in the field.

§ The type of legend marking on O.F. cable shall be as follows:

- d) Company Legend
- e) Legend containing telephone mark & international acceptable Laser symbol
- f) Type of Fibre– G.6571.A
- k) Number of Fibre
- l) Type of cable Loose tube– UNI TUBE
- m) Year of manufacture
- n) Sequential length marking
- o) Authority's name – KFON
- p) Diameter of the cable
- q) Cable ID

### 1.2.6. Cable Ends

§ Both cable ends (the beginning end and end of the cable reel) shall be sealed and readily accessible. Minimum 5 meter of the cable of the beginning end of the reel shall accessible for testing. Both ends of the cable shall be kept inside the drums and shall be located so as to be easily accessible for the test. The drum (confirming to GR No. G/CBD-O1/02 Nov. 94 and subsequent amendment) should be marked to identify the direction of rotation of the drum. Both ends of cable shall be provided with cable pulling (grip) stocking and the anti-twist device (free head hook). The wooden drums shall be properly treated against termites and other insects during transportation and storage. The diameter of the cable shall also be marked on the cable drum. The manufacturer shall submit the methodology used for the same

§ An anti-twist device (Free head hook) shall be provided, attached to the both the ends of the cable pulling arrangement. The arrangement of the pulling eye and its coupling system along with the anti-twist system shall withstand the prescribed tensile load applicable to the cable.

### The nominal drum length

§ Length of OF Cable in each drum shall be 2 Km 10% / 4Km 10% / 8Km± 10% / 10Km ± 10% and shall be supplied as per the order. The variation in length of optical fibre cable, as specified above (in each drum), shall be acceptable.

§ The fibres in cable length shall not have any joint.

§ The drum shall be marked with arrows to indicate the direction of rotation.

§ Packing list supplied with each drum shall have at least the following information:

- k) Drum No.
- l) Type of cables: UNI TUBE
- m) Physical Cable length
- n) No. of fibres
- o) Length of each fibre as measured by OTDR
- p) The Cable factor - ratio of fibre/cable length
- q) Attenuation per Km. of each fibre at 1310 & 1550 nm
- r) Authority's Name
- s) Manufacturers Name, Month, Year and Batch No.
- t) Group refractive index of fibre.
- l) Purchase Order No.
- m) Cable ID

### Colour coding in O.F. Cables:

## Volume- II

---

- § The colorant applied to individual fibres shall be readily identifiable throughout the lifetime of the cable and shall match and conform to the Munsell Colour Standards (EIA- 359-A) and also IEC Publication 304(4).
- § **Colour Coding Scheme:** the loose tubes are placed in circular format, the marking to indicate the loose tube no. "1" shall be in blue colour followed by loose tube no.2 of orange and so on for other tubes as per the colour scheme given in the technical specifications and complete the circular format by placing the dummy /fillers at the end.

### 1.2.6. Quality Requirements

The cable shall be manufactured in accordance with the international quality standards ISO 9001-2008 (latest issue) for which the manufacturer should be duly accredited. The Quality Manual shall be submitted by the manufacturer.

### 1.2.6. Raw Material

- § The cable shall use the raw materials approved against the GR No. TEC/GR/TX/ORM-01/04 SEP.09 and the subsequent amendment issued, if any.
- § Any other material used shall be clearly indicated by the manufacturer. The detailed technical specifications of such raw materials used shall be furnished by the manufacturer at the time of evaluation/testing.
- § The raw materials used from multiple sources is permitted and the source / sources of raw materials (Type and grade) from where these have been procured shall be submitted by the manufacturer.
- § The manufacturer can change the raw material from one approved source to other approved source with the approval of QA wing of purchaser. The change of source/grade of SM Optical Fibre shall call for fresh evaluation/testing.
- § The HDPE black in colour used for outer sheath shall be UV stabilized and shall withstand UV test for 2,000 hours(minimum)
- § The material used in optical fibre cable must not evolve hydrogen that will affect the characteristics of optical fibres.

**Note** A test certificate from a recognized laboratory or institutemay be acceptable for the UV stability of the HDPE sheath material as well as for the last point.

### 1.2.6.10. Cable Material Compatibility

Optical fibre, buffers/core tubes, and other core components shall meet the requirements of the compatibility with buffer/core tube filling material(s) and/or water-blocking materials that are in direct contact with identified components within the cable structure (This shall be tested as per clause no. 6.3.3 of Telecordia document GR-20-CORE issue 4, 2013.)

**Note** The tests may be conducted in house (if facility exist) or may be conducted at CACT or any other recognized laboratory. The test certificate may be accepted and the tests may not be repeated subsequently, in next type approvals, if the raw material used is of same make and grade.

### 1.2.6.11. Documentation

- § Complete technical literature in English with detailed cable construction diagram of various sub-components with dimensions, weight & test data and other details of the cable shall be provided.
- § All aspects of installation, operation, maintenance and fibre splicing shall also be covered in the handbook. The pictorial diagrams of the accessories (with model no. and manufacturer name) supplied along with the cable as package shall be also be submitted. A hard as well as soft copy of the manuals shall be provided.

### 1.2.6.12. Safety

- § The material used in the manufacturing of the self-supporting Optical fibre cables shall be non-toxic and dermatologically safe in its life time and shall not be hazardous to health. The manufacturer shall submit MSDS (Material safety Data Sheet) for all the material used in manufacturing of OF Cable to substantiate the statement.

**1.2.6.13. Factory Acceptance Test**

The FAT on cable accessories & fixtures of optical fibre cable shall include the following minimum tests as specified in Table below:

<b>Sl. No.</b>	<b>Factory Acceptance Test</b>
1	Visual and dimensional checks of all components
2	Tensile test
3	Slip test
4	Galvanising test
5	Wrapping test
6	Hardness test

*Table 62: FAT for aerial drop cable*

Equipment shall not be shipped to the Authority until required factory tests are completed satisfactorily, all variances are resolved, full test documentation has been delivered to the employer, and the employer has issued dispatch Certificate. Successful completion of the factory tests and the Buyer approval to shipment, shall in no way constitute final acceptance of the cable and associated accessories and fixtures.

For the cable hardware fittings & accessories, the minimum sampling rate, and batch acceptance criteria shall be as defined in IS 2486.

FAT tests shall include supply of proper calibration certificates, demonstration of satisfactory performance, evidence of correct equipment configuration and manufacturer's final inspection certificate / report.

**1.2.6.14. Site Acceptance Test (SAT)**

Prior to installation, every spooled fibre optic cable segment shall be tested for compliance with the Pre-shipment data previously received from the manufacturer. This requirement will preclude the installation of out of specification cable segments that may have been damaged during shipment. During the installation, spliced cable segments shall be tested and documented. Upon completion of a continuous cable path, all fibres within the cable path shall be demonstrated for acceptance of the cable path. Fibre Optic cable field testing stages are provided below.

<b>Sl No.</b>	<b>Test Description</b>	<b>Type of Test</b>	<b>Approximate Test Schedule</b>
1.	Pre-installation physical inspection.	Visual Inspection of the Cable / Drum / Batons.	Prior to cable installation.
2.	Pre-installation OTDR (Length)	OTDR distance (one direction)	Prior to cable installation.
3.	Pre-installation OTDR (Attenuation)	OTDR fibre attenuation (One direction)	Prior to cable installation.
4.	Per splice attenuation.	OTDR bidirectional splice loss.	At completion of cable route.
5.	Per splice OTDR	OTDR bidirectional.	At completion of cable route.
6.	Inspection of splice enclosure / cable routing	Visual inspection	During installation / After completion of cable route
7.	Inspection of joint seal.	Visual inspection	During installation / After completion of cable route

## Volume- II

---

SI No.	Test Description	Type of Test	Approximate Test Schedule
8.	Fibre Continuity & attenuation.	Power through connector	At completion of cable route.
9.	OTDR test	OTDR bidirectional	At completion of cable route.

*Table 63: Site Acceptance Tests for Aerial drop cable*

Complete and indexed records of all factory and site acceptance tests results shall be submitted to Authority for approval by the supplier in hardcopy & softcopy.

### **1.2.7 Aerial Drop Cable Accessories**

The Wedge type of Installation Accessories are as mentioned below:

- ξ Anchoring (Dead End) Assembly
- ξ Pole Bracket
- ξ Suspension Clamp Assembly
- ξ Adjustable Cable Storage Bracket
- ξ Stainless Steel Strap with Buckle

#### **1.2.7.1 Anchoring (Dead End) Assembly:**

Anchoring assemblies shall be used to firmly hold ADSS cable to a concrete, wood or steel pole and transmit the mechanical tension,

- ξ at the end of a run
- ξ at a major change in direction of over 20 degrees.

Each Anchoring Assembly includes:

- ξ One number wedge type tension Clamp (Dead End Clamp)
- ξ One number Pole bracket or wall bracket (Pole Bracket)

Anchoring assemblies shall be supplied in sets to ensure compatibility of the materials against wear of moving parts.

#### **1.2.7.2 Pole Bracket**

Universal Pole Bracket shall be used for Anchoring Assembly.

#### **1.2.7.3 Suspension Clamp Assembly**

Suspension Assembly shall be used for holding the ADSS cable at an intermediate point of support such as a pole. It can accommodate small angles of deviation up to 20 deg.

Each Suspension Assembly shall consist of:

- ξ One number body to hold the cable.
- ξ Hanging unit with wedge to fix the cable (with provision for fixing by SS Strap in pole or hole to fix in wall).

Suspension Assemblies shall be supplied in sets to ensure compatibility of the materials.

#### **1.2.7.4 Adjustable Cable Storage Bracket**

Cable Coil Rack is used to store the excess cables which is being maintained in the middle of the line and to use at the time of joints.

#### **1.2.7.5 Stainless Steel Strap and Buckles**

- ξ The Stainless steel strap shall consist of stainless steel strap of size 10 mm ±0.2 x 0.4mm ±0.05 mm and shall have tensile strength of 2.4KN min.
- ξ Tensile strength of strap shall be minimum 2.4KN which shall be tested on a loop with Buckle. Min one loops of 0.75 meter with one Buckle shall be considered for attaching the brackets to the poles.
- ξ The SS Strap shall be engraved with the name of the Manufacturer, month and year of manufacturing and length at a distance of approx. 250mm for traceability.
- ξ S S Strap shall be supplied in 50 meter roll in plastic dispenser casing with indication of remaining length.
- ξ The S S Buckle to suit above Strap shall be used to tension & fix it. It shall have a slot width of not less than 10.5 mm x 1 mm
- ξ Buckles shall be supplied in plastic bags containing 100 pcs per bag.

### **1.2.7. Anchoring Bolt**

Anchor bolt shall be used to fasten the cable to the building. Anchor bolt shall be hot dip galvanized as per relevant standards. The bolt should be designed in such a way that it should accommodate one tension hardware fittings

This Technical Specification contains the requirements for Installation Accessories & Fixtures to be used for erection of the Self Supporting Metal free Aerial / ADSS Optical Fibre Cables on the existing overhead alignments or Power line alignments up to 100m of span length.

The Wedge types of Installation Accessories are as mentioned below:

- ξ Anchoring (Dead End) Assembly
- ξ Pole Bracket
- ξ Suspension Clamp Assembly
- ξ Adjustable Cable Storage Bracket
- ξ Stainless Steel Strap with Buckle

### **1.2.7. Raw materials for Installation Accessories**

#### **Raw Material for Dead End Clamp:**

The clamp body, wedge and bail shall consists of an UV resistant thermoplastic with glass fibre (Polybutylene Terephthalate (PBT) / Polyamide which shall anchor/hold the cable. The following key criterion shall be followed for the design of the same:

There shall be no losable part in the process of clamping arrangement

Locking mechanism shall be wedge type self-locking.

#### **Raw material for Pole Bracket**

Pole Bracket for Anchoring Assembly shall be made out of an UV resistant thermoplastic with glass fibre (Polybutylene Terephthalate (PBT) / Polyamide.

#### **Raw material for Suspension Clamp**

The body and Wedge shall be made of UV resistant thermoplastic with glass fibre (Polybutylene Terephthalate (PBT) / Polyamide.

#### **Raw material for Adjustable Cable Storage Bracket**

Bracket and Cap made of Aluminium Alloy and all other items which includes rod, bolt, nut, washers etc., shall be of hot dip galvanised steel / Aluminium rod to avoid rust and corrosion.

#### **Raw material for Stainless steel Strap and Buckles**

The stainless steel material of the Strap shall be of high mechanical strength, corrosion and wear resistant as per ASTM SS 202.

The Buckle shall be made from ASTM SS 304 of thickness not less than 1 mm.

### **1.2.7. Testing of the accessories**

Design aspect of all Accessories shall be verified as per the description. The Type Test (for product qualification) and Acceptance Test (for batch acceptance by purchaser) shall be conducted at supplier premises or any NABL or COFRAC accredited Laboratory

#### **Tests for Dead End Clamp**

The following table details the Type tests and Acceptance Test for Dead End Clamp:

## Volume- II

Sl. No.	Test	Type Test	Acceptance Test
1	Visual	X	X
2	Dimensional	X	X
3	Raw material verification <sup>(1)</sup>	X	X
4	Tensile Test <sup>(2)</sup>	X	X

(1) Raw material data Sheet and test certificate to be verified

(2) For factory acceptance test duration of the test is 10 Minutes.

### Tensile Test

A minimum load value  $T(N) = 50\% - 75\%$  of Tensile Strength or MAT of the suitable cable, sustained for minimum one hour shall not damage the outer jacket of the cable such as piercing or creep. There shall be no displacement between the dead end fitting and cable. The change in attenuation of each fibre at the end of the test shall be  $\leq 0.1$  dB.

### Tests for Pole Bracket

The following table details the Type tests and Acceptance Test for Universal Pole Bracket.

Sl. No	Test	Type Test	Acceptance Test
1	Visual	X	X
2	Dimensional	X	X
3	Raw material verification <sup>(1)</sup>	X	X
4	Tensile Test <sup>(2)</sup>	X	X

(1) Raw material data Sheet and test certificate to be verified

(2) For factory acceptance test duration of the test is 10 Minutes.

### Tensile Test

A minimum load value  $T(N) = 3$  times the Tensile Strength of suitable cable or 2 KN whichever is lower shall not cause any breakage of pole bracket up to specified tensile strength.

### Suspension Clamp

The following table details the Type tests and Acceptance Test for Suspension Clamp.

Sl. No.	Test	Type Test	Acceptance Test
1	Visual	X	X
2	Dimensional	X	X
3	Raw material verification <sup>(1)</sup>	X	X
4	Tensile Test <sup>(2)</sup>	X	X
5	Slip Test	X	

(1) Raw material data Sheet and test certificate to be verified

(2) For factory acceptance test duration of the test is 10 Minutes.

### Tensile Test

## Volume- II

---

A minimum load of value of T (N) = 20% - 75% rated Tensile Strength of suitable cable or 1.2 KN whichever is lower, sustained for minimum one minute shall not cause any breakage of clamp.

### Slip Test

Suspension clamps shall enable the cable slip up to a load of 80N with a cable angle of 5° down to the horizontal axis and shall not result in any breakage of cable or collapse of pole structure.

### Tests for Adjustable Cable Storage Bracket

The following table details the type tests and Acceptance Test for Adjustable Cable Storage Bracket

SN	Test	Type Test	Acceptance Test
1	Visual	X	X
2	Dimensional	X	X
3	Raw material verification <sup>(1)</sup>	X	X

(1) Raw material data Sheet and test certificate to be verified

### Tests for Stainless Steel Strap and Buckle

Type tests on SS Straps and Buckles shall consist of Chemical Analysis Test Report of Composition. In addition, the SS Strap shall be tested for Tensile Strength and Ultimate Elongation.

Sl. No.	Test	Type Test	Acceptance Test
1	Visual	X	X
2	Dimensional	X	X
3	Raw material verification <sup>(1)</sup>	X	X
4	Tensile Test <sup>(2)</sup>	X	X
5	Chemical Properties	X	

(1) Raw material data Sheet and test certificate to be verified

(2) For factory acceptance test duration of the test is 10 Minutes.

### Mechanical Strength Test

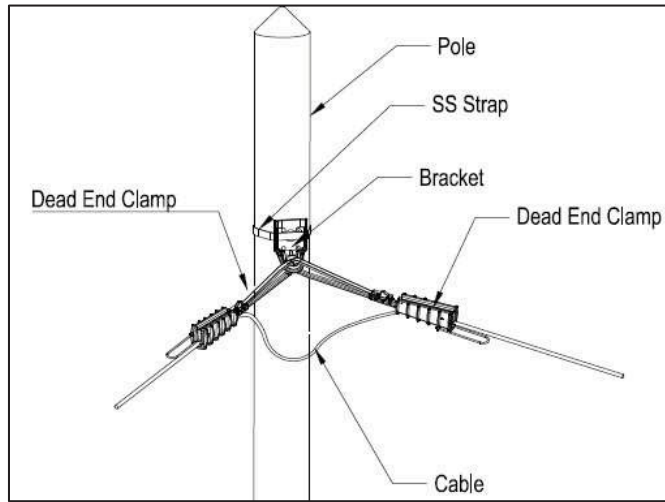
One loop of SS strap with a length of 0.75 meter and strapped with a buckle shall withstand a minimum load of 2.4 KN with Elongation 30% Min., in order to ensure that universal pole bracket can hold up to two dead-end clamp.

### 1.2.7. Installation Procedure for Accessories

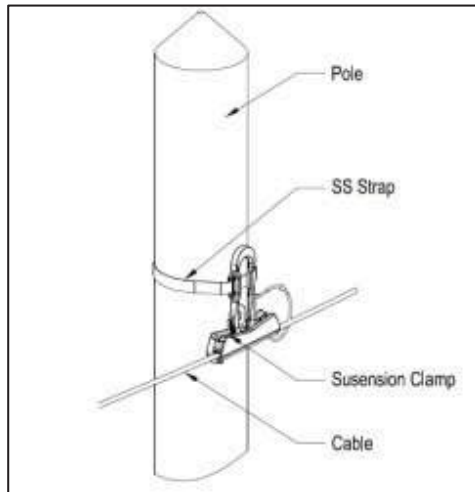
To be specified by the Manufacturer.

### Anchoring (Dead End) Assembly

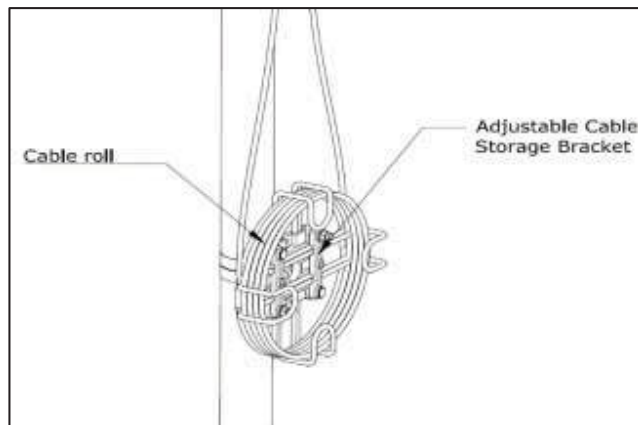




**Suspension Clamp Assembly**



**Adjustable Cable Storage Bracket**



1.2.7.10. Typical Drawings of Accessories

Dead-End Clamp

**HEAD END CLAMP FOR DROP CABLE AJSS**

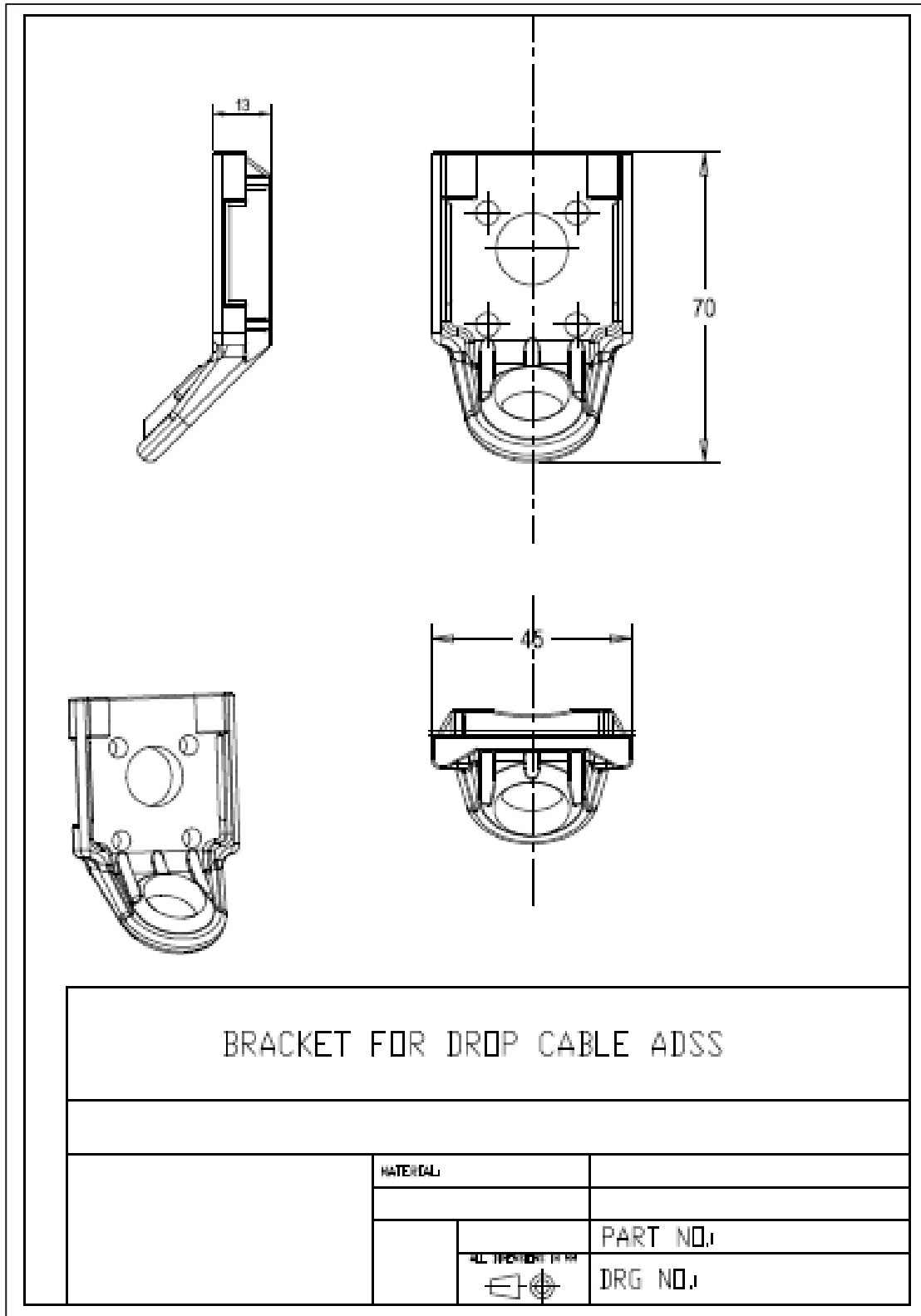
	REV. NO.
	PART NO.
	DWG NO.

	REV.	BY	CHECKED	DATE	SCALE	SHEET NO.	TOTAL SHEETS
1							
2							
3							
4							
5							
6							
7							
8							
9							
10							
11							
12							
13							
14							
15							
16							
17							
18							
19							
20							
21							
22							
23							
24							
25							
26							
27							
28							
29							
30							
31							
32							
33							
34							
35							
36							
37							
38							
39							
40							
41							
42							
43							
44							
45							
46							
47							
48							
49							
50							

**NOTE :**  
MINIMUM BREAKING LOAD : 1.8 KN

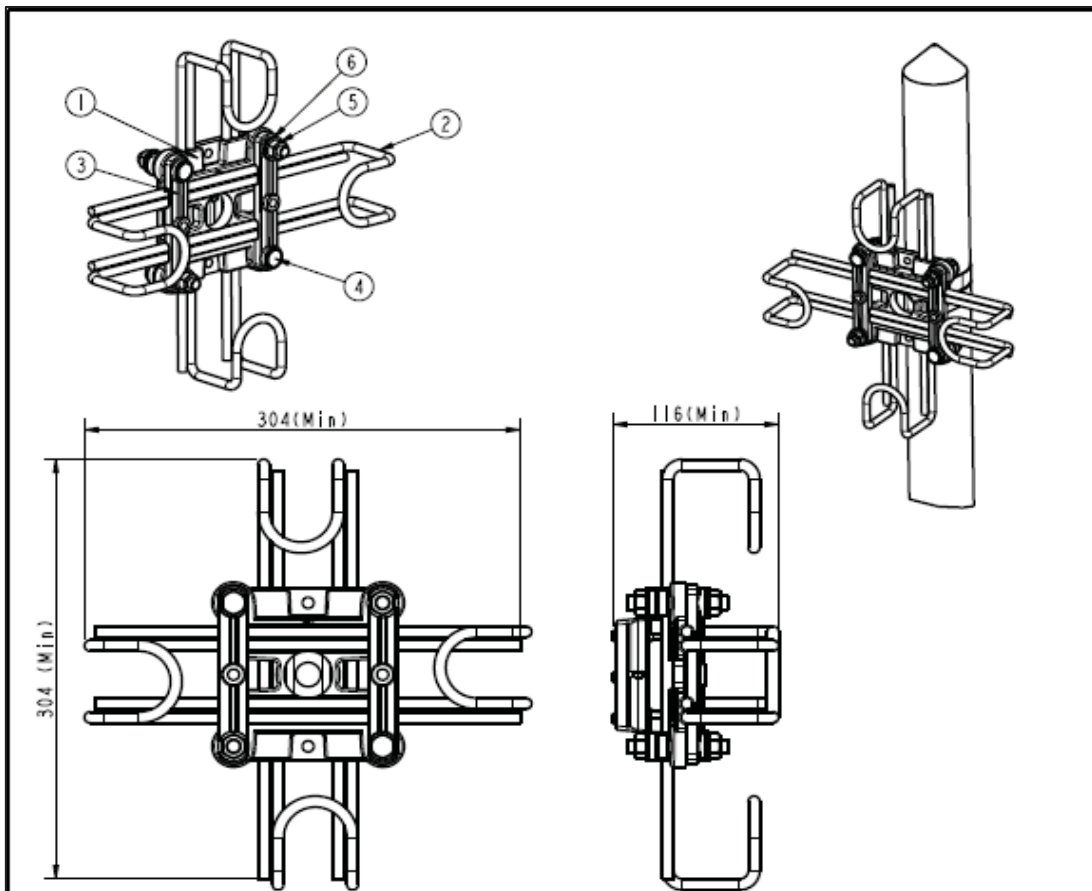
**Universal Pole Bracket**



**Suspension Clamp Assembly**

	<p style="text-align: center;"><b>SUSPENSION CLAMP FOR IRDP CABLE ADSS</b></p> <table border="1" style="width: 100%; border-collapse: collapse;"> <tr> <td style="width: 50%; text-align: center;">REVISED</td> <td style="width: 50%; text-align: center;">PART NO.</td> </tr> <tr> <td style="width: 50%; text-align: center;">DATE</td> <td style="width: 50%; text-align: center;">DWG NO.</td> </tr> </table>	REVISED	PART NO.	DATE	DWG NO.
REVISED	PART NO.				
DATE	DWG NO.				
<p><b>NOTE :</b>                  MATERIAL : UV RESISTANT THERMOPLASTIC                  MINIMUM BREAKING LOAD : 1.5 KN</p>					

**Adjustable Cable Storage Bracket**



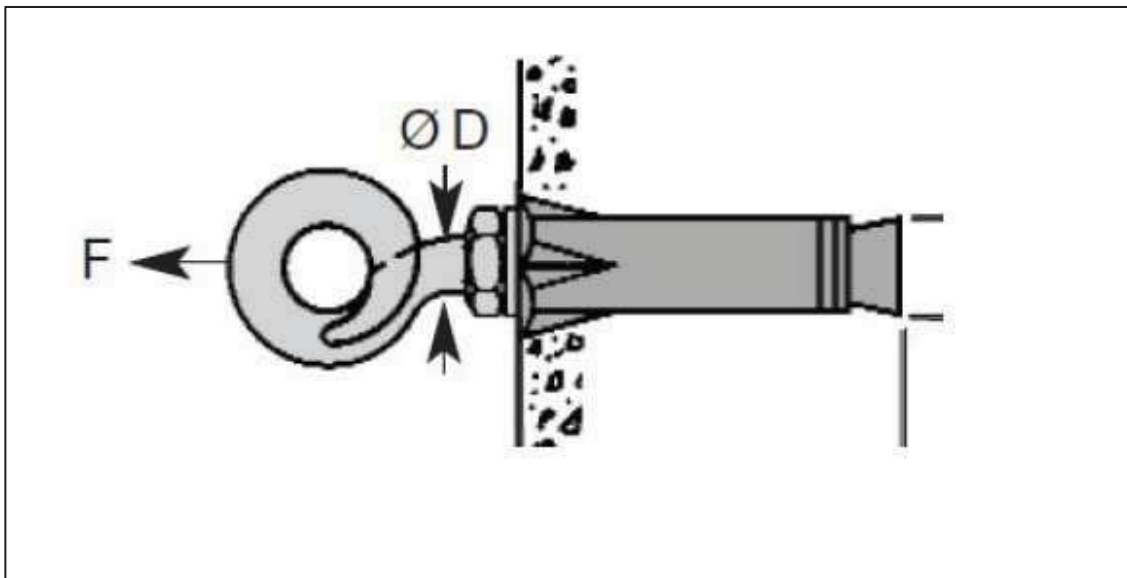
Note:  
Weight: 2 Kg (Approx)

6	4	M10 - Washer	Galvanised Steel
5	4	M10 - Nut	Galvanised Steel
4	4	M10 - Bolt	Galvanised Steel
3	4	CAP	Aluminium Alloy
2	4	ROD	Aluminium Alloy/ Galvanised Steel
1	1	Bracket	Aluminium Alloy
Rep	QTY	Description	Material

<b>ADJUSTABLE CABLE STORAGE BRACKET</b>			
		MATERIAL: See Table	
		PART NO.:	
		DRG NO.:	
		<small>ALL DIMENSIONS IN MM</small> 	



**Anchor Bolt**



**1.2.7.11. Quality Requirements**

- § The design, construction and fabrication of each accessories and fixtures shall be inherently robust and rigid and shall be as per the drawings given in the specifications.
- § Dimensions and weight of each accessory and fixture shall be specified by the manufacturer, wherever applicable  
Each accessory and fixture shall be manufactured in accordance with the international quality standards ISO 9001-2008 (latest issue) for which the manufacturer should be duly accredited. The Quality Manual shall be submitted by the manufacturer.
- § The accessories and fixtures shall be of good quality and superb finish
- § The composition of the material used in manufacturing accessories and fixtures shall be indicated.
- § In case of rods and wires, no joint shall be permitted except those in the base rod or wire before final drawing of rods.
- § The manufacturer shall possess the manufacturing and test facilities to test accessories and fixtures as per specifications
- § Parts of the fittings made of mild steel and/or carbon steel shall be manufactured as per IS: 2062 and or/IS 2004-9 and to be hot dip galvanized as per IS 2629
- § Aluminum alloy wire, aluminized steel, galvanized mild steel, carbon steel(as per IS standards), having required mechanical strength, corrosion resistance and formability, depending on the types of applications, shall be employed in manufacturing of the fitting.
- § All insulating/plastic rubber parts shall be made of UV resistant material
- § Aluminum components shall be of casted parts and no extruded parts are to be used to avoid sharp edges

**1.2.7.12. Documentation**

- § Complete technical literature in English with detailed cable construction diagram of various sub-components with dimensions, weight & test data and other details of the cable shall be provided.
- § All aspects of installation, operation, maintenance and fibre splicing shall also be covered in the handbook. The pictorial diagrams of the accessories (with model no. and manufacturer name) supplied along with the cable as package shall be also be submitted. A hard as well as soft copy of the technical as well as installation manuals shall be provided.

**1.2.7.13. Packing**

The packing of accessories shall carry the following information:-

- § Name of the product, manufacturer’s model, and serial number
- § Manufacturer’s name and trade mark
- § Type, diameter, of the optical fibre cable
- § Type of accessories & fixture and its code number
- § Batch number, date, month and year of production
- § Any other necessary marking

**1.2.7.14. Marking**

Following Mandatory marking shall be available on each installation Accessories including SS Strap:

- § Manufacturer`s name or logo or trade name
- § Month and year of manufacturing
- § Product Reference

**1.2.8 High Density Fibre Distribution Frame (FDMS Type I)**



<b>Make Offered:</b>				
<b>Model Offered:</b>				
<b>SL No.</b>	<b>Parameter</b>	<b>Minimum Specifications</b>	<b>Compliance (Yes/No)</b>	<b>Pg. No. in Ref Document</b>
1.	TEC compliant	TEC/GR/FDM-01/02 APR 2007, Type I § Wherever Specifications under this section shall contradict with TEC GR, then specifications under this section shall prevail. § Valid Type Approval Certificate (TAC) from Telecom Engineering Centre (TEC), New Delhi or Technical Specification Evaluation Certificate		



**Volume- II**

<b>Make Offered:</b>				
<b>Model Offered:</b>				
<b>SL No.</b>	<b>Parameter</b>	<b>Minimum Specifications</b>	<b>Compliance (Yes/No)</b>	<b>Pg. No. in Ref Document</b>
		(TSEC) from Quality Assurance Circle, BSNL, Bengaluru § Bidder is allowed to submit maximum Two FDMS manufacturer's/OEMs QF-103 along with Back to Back Legal Supply & Support Agreements		
2.	FDMS Outer Dimensions	§ Height 2200mm, Width 900mm, Depth 600mm, +/- 5%		
3.	48F S & P Module (6 Nos)	§ 19 inch Rack Mountable, 2U high, with 4 nos. 12F Splicing & Patching Trays, each preloaded with 12 Nos.single fibre pigtails of 0.9mm SCAPC connectorised and 1.5 meters in length & 12 Nos. of SCAPC Adaptors. The pigtails shall be color coded for easy identification.		
4.	24F S & P Module (4 Nos)	19 inch Rack Mountable, 1U high, with 2 nos. 12F Splicing & Patching Trays, each preloaded with 12 Nos.single fibre pigtails of 0.9mm SCAPC connectorised and 1.5 meters in length & 12 Nos. of SCAPC Adaptors. The pigtails shall be color coded for easy identification.		
5.	FDMS Exchange Type - I capacity	§ Total 384F (6 Nos. Modules of 48F and 4 Nos. Modules of 24F)		
6.	Splicing Module (1 No.)	§ 19 inch Rack Mountable, 3U high(16 Splice Trays of 12F) = 192 F.		
7.	Ventilation Method	§ Perforated Rear and Side Walls for efficient heat management of OLTE/PSU		
8.	Type of Adaptor, (CACT Approved)	§ SC-APC as per TEC GR TX/OFJ-01/05 NOV 2009		
9.	Patchcords Supplied	§ SC-APC Patch Cord (3 Meter length) 8 Nos.(for Testing/S&P Modules to Splitter/OLTE Connectivity)		
10.	OFC Entry Ports (Top)	§ 4 Nos. for 48F OFC Diameter 15-22mm, 6 Nos. for 24F OFC Diameter 10-14mm		
11.	Patch Cord Ports (Top)	§ 12 Nos. for 24 x 3mm SC-APC Patch Cords		
12.	Provisions for (on Top)	§ 8 Nos. for Entry of Power Cable/ Data Cable to MCBs		

**Volume- II**

<b>Make Offered:</b>				
<b>Model Offered:</b>				
<b>SL No.</b>	<b>Parameter</b>	<b>Minimum Specifications</b>	<b>Compliance (Yes/No)</b>	<b>Pg. No. in Ref Document</b>
13.	DIN Rail (1nos)	ξ For mounting of MCB		

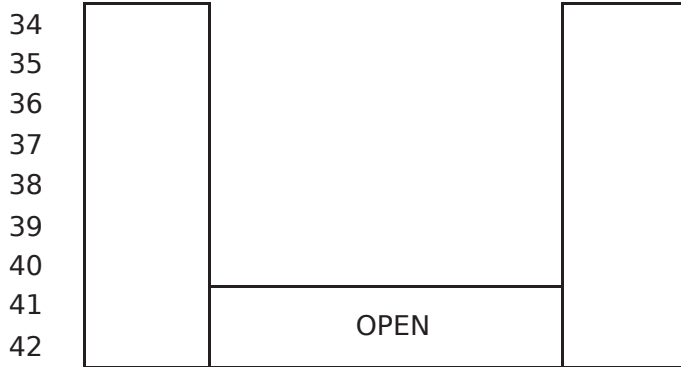
High (U)

- 1
- 2
- 3
- 4
- 5
- 6
- 7
- 8
- 9
- 10
- 11
- 12
- 13
- 14
- 15
- 16
- 17
- 18
- 19
- 20
- 21
- 22
- 23
- 24
- 25
- 26
- 27
- 28
- 29
- 30
- 31
- 32
- 33

OFC Cable Entry	OPEN	Power/Data Cable Entry
	48F S&P Module 1	
	48F S&P Module 2	
	48F S&P Module 3	
	48F S&P Module 4	
	48F S&P Module 5	
	48F S&P Module 6	
	HPMS	
	24F S&P Module 1	
	24F S&P Module 2	
	24F S&P Module 3	
	24F S&P Module 4	
	192F Splicing Module 1	
	OPEN	
	Splitter Box	
	Fibre Monitoring System	
Power Supply Unit		
OLTE (upto 10U High)		

2200mm Height x 600mm Depth

**Volume- II**



150mm	600mm	150mm
900mm		

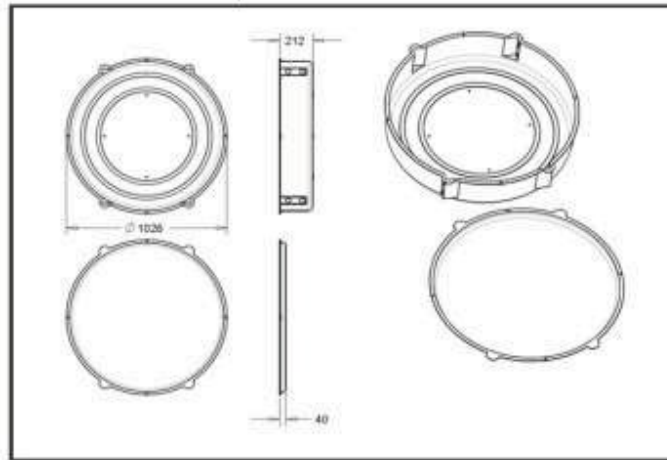
**1.2.9. Optical Splitter**



<b>Make Offered:</b>					
<b>Model Offered:</b>					
<b>SL No.</b>	<b>Parameter</b>	<b>Minimum Specifications</b>	<b>Compliance (Yes/No)</b>	<b>Pg. No. in Document</b>	<b>Ref</b>
1.	1:4/1:8	As per TEC GR No. TEC/GR/TX/OPT-001/01/ APRIL-12 with latest amendments.  Valid Type Approval Certificate (TAC) from Telecom Engineering Centre (TEC), New Delhi or Technical Specification Evaluation Certificate (TSEC) from Quality Assurance Circle, BSNL, Bengaluru			

*Table 64: Specifications for Optical Splitter*

**1.2.1 Spare Cable Box Type A (at PoP locations)**



Make Offered:				
Model Offered:				
Sl No.	Parameter	Minimum Specifications	Compliance (Yes/No)	Pg No. in Supporting Document
1.	Dimensions	Diameter 1.02 meter x Height 0.25 meter (Body + Cover)		
2.	Material	3mm Thick Fibre Glass Reinforced Polyester (FRP), 8 Kgs. Weight approx.		
3.	Wall Mounting	Embedded Galvanised MS C Channel 40 x 8 x 1.6mm (4 Nos.) With Slotted Holes for Wall mounting using M8 Expansion Bolts ( 4 Sets supplied with each Box)		
4.	Capacity	To Store minimum Meters each of 3 Nos. of 24F/48F Cables		
5.	Design Feature	Provided with provision for maintaining Minimum Cable Bending Diameter for 24F/48F O F Cable.		
6.	Separators	Provided with suitable built-in separators between cables, for easy operation.		
7.	Cable Entry/Exit	8 Nos. suitable for 4 Nos. of 24F/48F ADSS Cables.		
8.	Cover	Assembly with 4 Nos. Retainer Screws		

Table 65: Specifications for Spare Cable Box

**1.2.1 Runway segments for PoPs**

Make Offered:				
Model Offered:				
Sl No.	Parameter	Min. Specifications	Compliance (Yes/No)	Pg No. in Supporting Document
1.	Dimensions	Slotted Channel of Size 150mm x 50mm x 1.6mm, Powder-coated		

**Volume- II**

<b>Make Offered:</b>				
<b>Model Offered:</b>				
<b>Sl No.</b>	<b>Parameter</b>	<b>Min. Specifications</b>	<b>Compliance (Yes/No)</b>	<b>Pg No. in Supporting Document</b>
2.	Quantity	Supplied in length of 2 meters x 2 nos., with Hardware as required for mounting above FDMS Rack, for safe Entry of OFC & Other Cables, with mounting hardware suitable for Top mounting.		

**1.2.1 Street Box Type I (Joint Closure (Dome Type))**



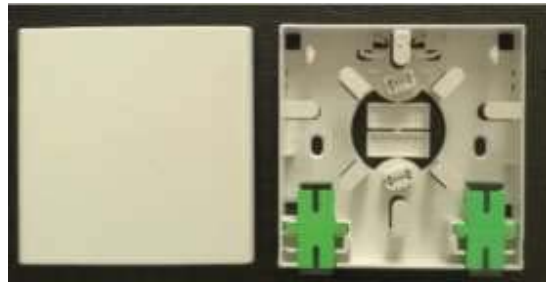
<b>Make Offered:</b>				
<b>Model Offered:</b>				
<b>SL No.</b>	<b>Parameter</b>	<b>Minimum Specifications</b>	<b>Compliance (Yes/No)</b>	<b>Pg. No. in Supporting Document</b>
1.	TEC compliant	<p>TEC/GR/TX/OJC-002/03/APR-2010, with latest amendments if any.</p> <p>§ Wherever specifications under this section shall contradict with TEC GR, then specifications under this section shall prevail.</p> <p>§ Valid Type Approval Certificate (TAC) from Telecom Engineering Centre (TEC), New Delhi or Technical Specification Evaluation Certificate (TSEC) from Quality Assurance Circle, BSNL, Bengaluru</p> <p>§ Bidder is allowed to submit maximumTwo BJC manufacturer's/OEMs QF-103 along with Back to Back Legal Supply &amp; Support Agreements. Also manufacturers who have got TSEC/TAC against GR No. TEC/GR/TX/OJC-002/03/APR-2010 and TEC GR No. TEC/GR/TX/OPT-001/01/ APRIL-12 will be allowed to make supplies against the same approvals.</p>		

**Volume- II**

<b>Make Offered:</b>				
<b>Model Offered:</b>				
<b>SL No.</b>	<b>Parameter</b>	<b>Minimum Specifications</b>	<b>Compliance (Yes/No)</b>	<b>Pg. No. in Supporting Document</b>
2.	BJC with 1x4 splitter	§ The closure should have an additional tray (total of 5 splice trays) which has the splitter pre-installed. The splitter should be tube type with 0.9mm leads un-connectorised and 1.5 meters long. The Input of the splitter shall be white and outputs shall be coloured for ease of identification		
3.	BJC with 1x4 splitter	§ The closure shall be supplied with pole mount kit. The kit should have atleast 2 hose clamps (75mm ~ 130mm) for securing to the pole		
4.	BJC with 1x4 splitter	§ The closure shall be supplied with 4 round port seals and 1 oval port seal of sealing of port with OFC cable. An extra round port seal shall be supplied which can take multiple 48/4F drop cables		
5.	BJC with 1x8 splitter	§ The closure should have an additional tray (total of 5 splice trays) which has the splitter pre-installed. The splitter should be tube type with 0.9mm leads un-connectorised and 1.5 meters long. The Input of the splitter shall be white and outputs shall be coloured for ease of identification		
6.	BJC with 1x8 splitter	§ The closure shall be supplied with pole mount kit. The kit should have at least 2 hose clamps (75mm ~ 130mm) for securing to the pole		
7.	BJC with 1x8 splitter	§ The closure shall be supplied with 4 round port seals and 1 oval port seal of sealing of port with OFC cable. An extra round port seal shall be supplied which can take multiple 48/4F drop cables.		

*Table 66: Specifications for Fibre Splice Joint Closure*

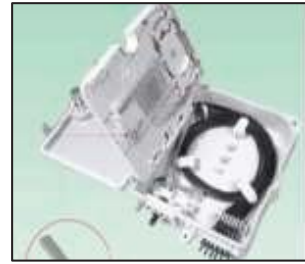
1.2.13 FTB Type I



Make Offered:				
Model Offered:				
SL No.	Parameter	Minimum Specifications	Compliance (Yes/No)	Pg. No. in Supporting Document
1.	TEC Compliant	<p>TEC/GR/TX/FTB-02/02/APR-2010 – Type – I, with latest amendments if any.</p> <p>ξ Wherever specifications under this section shall contradict with TEC GR, then specifications under this section shall prevail.</p> <p>ξ Valid Type Approval Certificate (TAC) from Telecom Engineering Centre (TEC), New Delhi or Technical Specification Evaluation Certificate (TSEC) from Quality Assurance Circle, BSNL, Bengaluru</p> <p>ξ Bidder is allowed to submit maximum Two FTB manufacturer’s/OEMs QF-103 along with Back to Back Legal Supply &amp; Support Agreements. Also manufacturers who have got TSEC/TAC against GR No. As per GR No. TEC/GR/TX/FTB-02/02/APR-2010 – Type – II &amp; Type III will be allowed to make supplies against the same approvals.</p>		
2.	Others	<p>ξ FTB shall be supplied with 2 nos of SCAPC adapters and pigtails. The fibre used in the pigtail shall be G657A1 type</p>		
3.		<p>ξ FTB shall be able to properly secure the 4F cable inside the unit</p>		
4.		<p>ξ FTB shall be indoor type and shall be supplied with wall mounting accessories</p>		

Table 67: Specifications for FTB Type I

**1.2.14 Street box Type II (FTB Type II)**



Make Offered:				
Model Offered:				
SL No.	Parameter	Minimum Specifications	Compliance (Yes/No)	Pg. No. in Supporting Document
1.	TEC compliant	<p>TEC/GR/TX/FTB-02/02/APR-2010 – Type – II, with latest amendments if any.</p> <p>ξ Wherever specifications under this section shall contradict with TEC GR, then specifications under this section shall prevail.</p> <p>ξ Valid Type Approval Certificate (TAC) from Telecom Engineering Centre (TEC), New Delhi or Technical Specification Evaluation Certificate (TSEC) from Quality Assurance Circle, BSNL, Bengaluru</p> <p>ξ Bidder is allowed to submit maximum Two FTB manufacturer's/OEMs QF-103 along with Back to Back Legal Supply &amp; Support Agreements. Also manufacturers who have got TSEC/TAC against GR No. As per GR No. TEC/GR/TX/FTB-02/02/APR-2010 – Type – II &amp; Type III will be allowed to make supplies against the same approvals</p>		
2.		<p>ξ FTB shall be supplied with 48 nos of SCAPC adapters and pigtails. The fibre used in the pigtail shall be G657A1 type</p>		
3.		<p>ξ The FTB shall be supplied with pole mount and wall mount kit</p>		
4.		<p>ξ FTB size can be smaller than the one specified in the GR</p>		
5.		<p>ξ It shall have the following provisions for cable entry</p> <ul style="list-style-type: none"> <li>o 1 Express loop entry for mid span cable entry</li> </ul>		



Make Offered:				
Model Offered:				
SL No.	Parameter	Minimum Specifications	Compliance (Yes/No)	Pg. No. in Supporting Document
		o 12 nos of drop cable entries		
6.		ξ Provision for holding 48 nos of splice protection sleeves		
7.		ξ Provision for locking the box		
8.		ξ Should IP 65 rated		
9.		ξ Should have provision to integrate tube type splitter (upto 1x8)		

Table 68: Specifications for SJC/BJC

### 1.2.15 Fibre Patch Cord

Make Offered:				
Model Offered:				
SL No.	Parameter	Minimum Specifications	Compliance (Yes/No)	Pg. No. in Supporting Document
1.	TEC Compliant	TEC/GR/TX/OFJ-01/05. NOV 2009, with latest amendments if any – length as per field requirement Valid Type Approval Certificate (TAC) from Telecom Engineering Centre (TEC), New Delhi or Technical Specification Evaluation Certificate (TSEC) from Quality Assurance Circle, BSNL, Bengaluru		
2.	Type of Connector	SC/LC-APC (As per field requirement)		

Table 69: Specifications for Fibre Patch Cord

### 1.2.16 Rack Cabinets

Make Offered:				
Model Offered:				
SL No	Parameter	Minimum Specifications	Compliance (Yes/No)	Pg. No. in Supporting Document
1.	Rack Height	42 U		
2.	Rack Width	19''		
3.	Colour	Black		
4.	Front door	16 gauge		
5.	Rear door	18 gauge		
6.	Side panels	18 gauge		

Make Offered:				
Model Offered:				
SL No	Parameter	Minimum Specifications	Compliance (Yes/No)	Pg. No. in Supporting Document
7.	Others	<ol style="list-style-type: none"> <li>1. The front door shall be insulated metallic door fitted with rubber gasket and a central glass for clear visibility of all components installed in the rack</li> <li>2. The rack shall have two cable managers fully separated so they do not cross each other for power and network cables.</li> <li>3. The Rack shall have provision for two separate top entries one for power and one for network cables.</li> <li>4. The Rack shall have sufficient number of shelves to accommodate specified equipment in the Point of Presence (PoP)</li> </ol>		

Table 70: Specifications for rack

### 1.2.1 Pre-fabricated Shelter

Make Offered:				
Model Offered:				
SL No	Parameter	Minimum Specifications	Compliance (Yes/No)	Pg. No. in Supporting Document
1.	Panels	<ul style="list-style-type: none"> <li>ξ Outer wall and roof shall consist of Polyurethane insulated 60mm thick</li> <li>ξ Inner and outer skin material shall be min 1.0mm thick GI sheet.</li> <li>ξ Panels shall have MS frame. Internal and external paint shall be as per KFON requirement.</li> </ul>		
2.	Main Door	One with lock, hinge and tower bolt		
3.	Window	One with grill, lockable Shutter , bolt etc		
4.	Size	<p><b>Core PoP:</b></p> <ul style="list-style-type: none"> <li>ξ Should accommodate 4 Nos of 42 U Racks, 2 UPS and Access area (Approx. 300 Sq ft)</li> </ul> <p><b>Aggregation PoP:</b></p> <ul style="list-style-type: none"> <li>ξ Should accommodate 3 Nos of 42 U Racks, 2 UPS and Access area (Approx. 200 Sq ft)</li> </ul> <p><b>Pre- Aggregation PoP:</b></p> <ul style="list-style-type: none"> <li>ξ Should accommodate 3 Nos of 42 U Racks, 2 UPS and Access area (Approx. 200 Sq ft)</li> </ul> <p><b>Spur PoP:</b></p> <ul style="list-style-type: none"> <li>ξ Should accommodate 3 Nos of 42 U Racks, 2 UPS and Access area (Approx. 200 Sq ft)</li> </ul>		
5.	Superstructure wind load	150 Kmph		
6.	Other Requirements	Shelter shall be self-standing, self-supporting galvanized steel structure		
7.	Other Requirements	Door rain guard to be provided above the door for smooth operations.		

**Volume- II**

<b>Make Offered:</b>				
<b>Model Offered:</b>				
<b>SL No</b>	<b>Parameter</b>	<b>Minimum Specifications</b>	<b>Compliance (Yes/No)</b>	<b>Pg. No. in Supporting Document</b>
8.	Other Requirements	Shelter shall have cut-outs for following: <ul style="list-style-type: none"> <li>☐ Fibre cable</li> <li>☐ Power cable</li> <li>☐ Air Condition inlet &amp; outlet</li> <li>☐ Earthing/Grounding cable</li> </ul>		
9.	Other Requirements	Shelter shall be water and dust proof.		
10.	Other Requirements	Shelter shall have solid hook mounted door stopper		
11.	Other Requirements	The foundation shall be made of reinforced cement concrete with suitable grade to sustain entire load of shelter and equipment.		
12.	Other Requirements	The foundation shall be designed in accordance with local rules and regulations and the municipal / concerned government authorities guidelines to be adhered.		
13.	Other Requirements	While constructing the foundation bearing capacity of soil, seismic load and wind load to be accounted for.		
14.	Other Requirements	The foundation shall support the shelter at least 4 points with vertical RCC Column having arrangement of base plate and foundation bolt to fix the shelter steel I-beams.		
15.	Other Requirements	The shelter shall have adequate lighting system and safety equipment.		
16.	Other Requirements	The shelter should be made-up of insulation material to prevent the heat conduction		
17.	Other Requirements	The shelter shall have environmental sensor to monitor the temperature and Humidity		
18.	Other Requirements	The shelter shall have fire extinguishing system.		
19.	Other Requirements	The shelter shall be installed 600mm above the true ground level. Proper PCC works to be carried out below the shelter footprint area and additional 1.2m around the shelter footprint area to avoid any vegetation growth.		
20.	Other Requirements	All cables shall be properly routed and cable gland & cable managers to be provided		
21.	Other Requirements	The shelter shall have a provision of at least 10m cable rollout in all the shelter.		
22.	Other Requirements	The shelter shall have access control System with reader supports both biometric and Smart Cards, Push button, Magnetic lock. The Access Control System Authentication shall happen through the centralized access control system server which will be placed at the NOC location.		
23.	Other Requirements	The Shelter shall be equipped with sufficient numbers of ABC Powder type fire extinguisher with adequate capacity for fire safety		

## Volume- II

Make Offered:				
Model Offered:				
SL No	Parameter	Minimum Specifications	Compliance (Yes/No)	Pg. No. in Supporting Document
24.	Other Requirements	The Shelter shall be equipped with emergency lights to provide illumination level of 600 - 750 lux in the shelter for 8 hours in case of power failure.		
25.	Other Requirements	The shelter shall have provision for adequate lighting so that illumination level of 750 – 1000 lux is maintained.		
26.	Other Requirements	The Entire Power system installed in shelter shall comply with Kerala State Electricity Board Ltd. (KSEBL) for Electrical Earthing. This includes all Earth and Ground pits.		
27.	Other Requirements	The SI shall provide acrylic based polymer coating in three layers to cover entire roof joints to provide rain shield on the shelter and the coating shall withstand UV rays and expansion / contraction under extreme weather condition		

Table 71: Specifications for pre-fabricated shelter

### 1.2.18 Pole

Make Offered:			
Model Offered:			
SL No	Minimum Specifications	Compliance (Yes/No)	Pg. No. in Supporting Document
1.	The street pole shall be of GI Class B of reputed make		
2.	Both outer and inner surfaces shall be galvanized.		
3.	Outer Diameter of Street pole shall be min 100mm		
4.	Height of pole shall be 7 metre above the ground		
5.	The Pole will be fixed on the ground with suitable foundation and over built.		

Table 72: Specifications for Pole

### 1.2.19 OPGW Cable

#### 1.2.19.1. Fibre Optic cable

The OPGW proposed shall be installed under following conditions;

- 1) Live line installation:- On existing line with all circuits of the transmission line charged to their rated voltage.
- 2) Installation in line spans without earth wire in existing line under shutdown condition:- In some of the existing line spans the earth wire will not be available or during installation if earth wire breaks in that condition the SI has to lay the OPGW cable under shutdown condition.
- 3) Installation on transmission lines under construction:- The OPGW cable shall be laid after installation of towers and when ready for stringing

In addition to the above mentioned works, if any other work, required for fully functional system, shall also be in the scope of the SI.

### **1.2.19.2. Cable drums, Marking, Packaging and Transport**

All optical fibre cable shall be supplied on strong wooden drums provided with lagging with adequate strength, constructed to protect the cabling against all damage and display-cement during transit, storage and subsequent handling during installation.

- a) The following marking shall be done on each side of the cable drums.
  - i. Drum number
  - ii. Consignee's name and address
  - iii. SI's name and address
  - iv. Type of cable
  - v. Number of fibres
  - vi. Type of fibres
  - vii. Year of manufacturing, month & batch no
  - viii. Name of manufacturer
- b) Total cable length
- c) Inner end marking and Outer end marking

Packing list supplied with each drum shall have all the information provided on marking on the respective cable drum and following additional information: OTDR length measurement of each fibre and Ratio of fibre and cable length.

### **1.2.19.3. Optical fibre cable marking**

A suitable marking shall be applied in order to identify this cable from other cables. Marking on the cable shall be indelible, of durable quality, shall last long and shall be applied at regular interval of one-meter length. Marking shall be imprinted and must clearly contrast with the surface and colors used must withstand the environmental influences experienced in the field. The accuracy of the sequential marking must be within  $\pm 0.5\%$  of the actual measured length. The sequential length marking must not rub off during normal installation. In case laser printing is used the marking shall not exceed 0.15 mm depth. The optical fibre cable shall have the following markings in every meter.

- i. Type of Cable
- ii. Running meter length
- iii. Number of fibres
- iv. Type of fibre
- v. Laser symbol & caution notice
- vi. Year of manufacture and batch no.
- vii. Manufacturer's name
- viii. Name: KFON Ltd.(for Package A) and KSEBL(for Package B)

### **1.2.19.4. Applicable Standards**

The applicable standards are mentioned in the respective technical section. The offered equipment shall conform to the standards mentioned in the specification except to the extent modified by this specification. In case of any discrepancy between the description given in the specification and the standards, the provisions of the technical specification shall be followed. The parameters not specifically mentioned in this specification shall conform to the standard mentioned in this specification.

Specifications and codes shall be the latest version, inclusive of revisions, which are in force at the date of the contract award. Where new specifications, codes, and revisions are issued during the period of the contract, the SI shall attempt to comply with such, provided that no additional expenses are charged to the KSEBL without KSEBL's written consent.

## Volume- II

---

In the event the SI offers to supply material and/or equipment in compliance to any standard other than Standards listed herein, the SI shall include with their proposal, full salient characteristics of the new standard for comparison.

In case values indicated for certain parameters in the specifications are more stringent than those specified by the standards, the specification shall override the standards.

### **1.2.19.5. OPGW Cabling & Associated Hardware Fittings**

This section describes the functional & technical specifications of **48 fibres OPGW** cabling and associated hardware fittings.

#### **1.2.19.5.1. Required Optical Fibre Characteristics**

This characteristics of optical fibre shall be according to the Technical Specifications for Single Mode Optical Fibre mentioned at to be provided under this specification.

#### **1.2.19.5.2. Fibre Optic Cable Construction**

Overhead Fibre Optic Cables shall be 48 Fibre OPGW (Optical Ground Wire). The OPGW cable is proposed to be installed on 220/110kV transmission lines spread across Kerala State. The list is enclosed as Annexure. The design of cable shall account for the varying operating and environmental conditions that the cable shall experience while in service. The OPGW cable to be supplied shall be designed to meet the overall requirements of all the transmission lines. Normally the tower span of the lines shall not exceed 600m, however, some of the spans may be more than 600m. The exact details shall be collected by the SI during survey. To meet the overall requirement of all the transmission lines, the SI may offer more than one design without any additional cost to Authority, in case span length of more than 600m is found during survey. The typical details of transmission lines are indicated in the Annexure. Any other details, as required for cable design etc. shall be collected by the SI during survey. It may also be noted that some of the transmission line routes may be added or deleted during engineering stage.

#### **1.2.19.5.3. Transmission Line Details**

Details required for the cable design etc. shall be collected by the SI during the survey.

#### **1.2.19.5.4. Optical Fibre Cable Link Lengths**

The estimated optical fibre link lengths for are provided as attachment to this tender as transmission line route length. However, the SI shall supply & install the optical fibre cable as required based on detailed site survey to be carried out by the SI during the project execution. The SI shall verify the transmission line route length during the survey and the Contract price shall be adjusted accordingly.

**For the purpose of payment, the optical fibre link lengths are defined as transmission line route length from the Gantry at one terminating station to the Gantry in the other terminating station.**

The price of optical fibre cable quoted in the Bid price Schedules shall take into account various factors such as sag, service loops, splicing, working lengths & wastage etc. and **no additional payment shall be payable in this regard**. The price of optical fibre cable quoted in the Bid price Schedules shall take into account all such factors.

#### **1.2.19.5.5. Optical Fibre Identification**

Individual optical fibres within a fibre unit and fibre units shall be identifiable in accordance with EIA/TIA 598 or IEC 60304 or Bellcore GR-20 colour-coding scheme.

Colouring utilized for colour coding optical fibres shall be integrated into the fibre coating and shall be homogenous. The colour shall not bleed from one fibre to another and shall not fade during fibre preparation for termination or splicing.

## Volume- II

---

Each cable shall have traceability of each fibre back to the original fibre manufacturer's fibre number and parameters of the fibre. If more than the specified number of fibres are included in any cable, the spare fibres shall be tested by the cable manufacturer and any defective fibres shall be suitably bundled, tagged and identified at the factory by the vendor.

### 1.2.19.5.6. Buffer Tube

Loose tube construction shall be implemented. The individually coated optical fibre(s) shall be surrounded by a buffer for protection from physical damage during fabrication, installation and operation of the cable. The fibre coating and buffer shall be strippable for splicing and termination. Each fibre unit shall be individually identifiable utilizing colour coding. Buffer tubes shall be filled with a water-blocking gel.

### 1.2.19.5.7. Optical Fibre Strain & Sag-tension chart

The fibre optic cable shall be designed and installed such that the optical fibres experience no strain under all loading conditions defined in IS 802. Zero fibre strain condition shall apply even after a 25 year cable creep.

For the purpose of this specification, the following definitions shall apply:

- a) **Maximum Working Tension (MWT)** as the maximum cable tension at which there is no fibre strain.
- b) The **no fibre strain condition** as fibre strain of less than or equal to 0.05%, as determined by direct measurements through IEC/ ETSI (FOTP) specified optical reflectrometry techniques.
- c) The Cable **strain margin** defined as the maximum cable strain at which there is no fibre strain.
- d) The cable **Maximum Allowable Tension (MAT)** as the maximum tension experienced by the Cable under the worst case loading condition.
- e) The cable **max strain** defined as the maximum strain experienced by the Cable under the worst case loading condition.
- f) The cable **Every Day Tension (EDT)** defined as the maximum cable tension on any span under normal conditions.
- g) The **Ultimate /Rated Tensile Strength (UTS/ RTS/ breaking strength)** as the maximum tensile load applied and held constant for one minute at which the specimen shall not break.

While preparing the Sag-tension charts for the OPGW cable the following conditions shall be met:

- (a) The Max Allowable Tension (MAT) / max strain shall be less than or equal to the MWT/Strain margin of the cable.
- (b) The sag shall not exceed the earth wire sag in all conditions.
- (c) The Max Allowable Tension shall also be less than or equal to 0.4 times the UTS.
- (d) The 25 year creep at 25% of UTS (creep test as per IEEE 1138) shall be such that the 25 year creep plus the cable strain at Max Allowable Tension (MAT) is less than or equal to the cable strain margin.
- (e) The everyday tension (EDT) shall not exceed 20% of the UTS for the OPGW cable.
- (f) The Sag-tension chart of OPGW cable indicating the maximum tension, cable strain and sag shall be calculated and submitted along with the bid under various conditions mentioned below:
  - I. 53° C , no wind and no ice
  - II. 32° C, no wind and no ice
  - III. 0°C, no wind and no ice
  - IV. 32° C, full wind and no ice
  - V. 32° C, 75% full wind and no ice

VI. 0° C, 2/3rd / 36% of full wind (IS 802:1977/1995)

The above cases shall be considered for the spans from 100m to 600m or higher span length in the range of 50m spans. Max. vertical sag, max. tension and max sag at 0° C & no wind shall be considered for in line with the design parameter of transmission line. The full wind load shall be considered as the design wind load for all the specified transmission lines as per relevant IS 802 version and the sag-tension chart shall be submitted considering the transmission lines. In case of any span higher than 600m, suitable OPGW cable meeting sag-tension requirement of transmission line shall also be provided by the SI. The SI shall submit the stringing chart for review of Authority.

### **1.2.19.5.8. Cable Materials**

The materials used for optical fibre cable construction, shall meet the following requirements:

#### **1.2.19.5.8.1 Filling Materials**

The interstices of the fibre optic unit and cable shall be filled with a suitable compound to prohibit any moisture ingress or any water longitudinal migration within the fibre optic unit or along the fibre optic cable. The water tightness of the cable shall meet or exceed the test performance criteria as per IEC-794-1-F-5.

The filling compound used shall be a non-toxic homogenous waterproofing compound that is free of dirt and foreign matter, non-hygroscopic, electrically non-conductive and non-nutritive to fungus. The compound shall also be fully compatible with all cable components it may come in contact with and shall inhibit the generation of hydrogen within the cable.

The waterproofing filling materials shall not affect fibre coating, colour coding or encapsulant commonly used in splice enclosures, shall be dermatologically safe, non-staining and easily removable with a non-toxic cleaning solvent.

#### **1.2.19.5.8.2 Metallic Members**

When the fibre optic cable design incorporates metallic elements in its construction, all metallic elements shall be electrically continuous.

### **1.2.19.5.9. Marking, Packaging and Shipping**

This section describes the requirements for marking, packaging and shipping the overhead fibre optic cable.

- a) **Drum Markings:** Each side of every reel of cable shall be permanently marked in white lettering with the vendors' address, the Authority's destination address, cable part number and specification as to the type of cable, length, number of fibres, a unique drum number including the name of the transmission line & segment no., factory inspection stamp and date.
- b) **Cable Drums:** Optical fibre cabling shall be supplied on strong drums provided with lagging of adequate strength, constructed to protect the cabling against all damage and displacement during transit, storage and subsequent handling during installation. Both ends of the cable shall be sealed as to prevent the escape of filling compounds and dust & moisture ingress during shipment and handling. Spare cable caps shall be provided with each drum as required.

The spare cable if any shall be supplied on sturdy, corrosion resistant, steel drums suitable for long periods of storage and re-transport & handling.



There shall be no factory splices allowed within a continuous length of cable. Only one continuous cable length shall be provided on each drum. The lengths of cable to be supplied on each drum shall be determined by a "schedule" prepared by the SI.

### **1.2.19.5.10. OPGW cable installation requirements**

Most of the OPGW fibre optic cables to be installed under this project shall be installed under live line conditions, i.e. with all the circuits of the transmission line charged to their rated voltage. However, some of OPGW cables may be installed in off-line conditions. The actual quantities for both types shall be finalized during project execution after detailed survey.

The OPGW cable shall be installed at the top of the tower by replacing the existing ground wire. The SI shall carry out re-tensioning of the existing earth wire wherever required to maintain the adequate clearances for live line stringing of fibre optic cables. However, in exceptional cases installation of OPGW cable below conductor may also be considered on low voltage lines which shall be decided during detailed engineering.

For new Transmission lines site survey shall be conducted once tower stub setting is completed. Any design data of tower and transmission line etc. for these new routes shall be collected from Authority by the SI. The SI shall lay the OPGW cable after installation of towers by KSEBL's transmission line SI.

Before transporting the OPGW cable to the tower locations from the storage area, the testing (fibre loss and length measurement using OTDR) of OPGW in each drum shall be carried out by the SI in the presence of Authority's/officials designated by Authority. After installation of OPGW cable, the testing of each section shall be carried out again by the SI in presence of Authority's/officials designated by Authority. In case of any damage/high loss in the fibre, the total length of that particular section of OPGW cable shall be replaced by SI. SI shall supply new OPGW cable in place of damaged cable.

Supervision of Installation -The SI shall supervise the stringing at site as per the approved stringing procedure. Site visit for supervision shall be carried out as per instruction of Authority. The Supervision/Inspection work in SI's scope shall mainly include inspection as per stringing procedure, proper location of drum site, installation of stringing blocks/pulleys, proper sagging, proper installation of hardware, proper tension as per Sag-Tension chart, provision of service loops of OPGW in jointing locations etc.

### **1.2.19.5.11. Optical Ground Wire (OPGW)**

OPGW cable construction shall comply with IEEE-1138, 1994. The cable provided shall meet both the construction and performance requirements such that the ground wire function, the optical fibre integrity and optical transmission characteristics are suitable for the intended purpose. The cable shall consist of optical fibre units as defined in this specification. There shall be no factory splices within the cable structure of a continuous cable length.

The composite fibre optic overhead ground wire shall be made up of buffered optical fibre units (fibres in the buffer tube) embedded in a water tight aluminium / aluminium alloy/stainless steel protective central fibre optic unit surrounded by concentric-lay stranded metallic wires in single or multiple layers. The dual purpose of the composite cable is to provide the electrical and physical characteristics of conventional overhead ground wire while providing the optical transmission properties of optical fibre.

### **1.2.19.5.11. Central Fibre Optic Unit**

The central fibre optic unit shall be designed to house and protect multiple buffered optical fibre units from damage due to forces such as crushing, bending, twisting, tensile stress and moisture. The central fibre optic unit and the outer stranded metallic conductors shall serve together as an integral unit to protect the optical fibres from degradation due

## Volume- II

---

to vibration and galloping, wind and ice loadings, wide temperature variations, lightning and fault current, as well as environmental effects which may produce hydrogen.

The OPGW design of dissimilar materials such as stainless steel tube with aluminium or aluminium-clad-steel wire strands are not allowed. Central fibre optic unit may be of aluminium or stainless steel tube with aluminium protective coating. In case of aluminium protective coating, the coating must completely cover the tubes leaving no exposed areas of tubing that can make electrical contact either directly or indirectly through moisture, contamination, protrusions, etc. with the surrounding stranded wires. The tube may be fabricated as a seamless tube, seam welded, or a tube without a welded seam.

### 1.2.19.5.11.2 Basic Construction

The cable construction shall conform to the applicable requirements of this specification, applicable clauses of IEC 61089 related to stranded conductors and the table given below on OPGW Mechanical and Electrical Characteristics. In addition, the basic construction shall include bare concentric-lay-stranded metallic wires with the outer layer having left hand lay. The wires may be of multiple layers with a combination of various metallic wires within each layer. The direction of lay for each successive layer shall be reversed. The finished wires shall contain no joints or splices unless otherwise agreed to by the Authority and shall conform to all applicable clauses of IEC 61089 as they pertain to stranded conductors. The wires shall be so stranded that when the complete OPGW is cut, the individual wires can be readily regrouped and then held in place by one hand.

#### 1.2.19.5.11.3. Breaking Strength

The rated breaking strength of the completed OPGW shall be taken as not more than 90 percent of the sum of the rated breaking strengths of the individual wires, calculated from their nominal diameter and the specified minimum tensile strength.

The rated breaking strength shall not include the strength of the optical unit. The fibre optic unit shall not be considered a load bearing tension member when determining the total rated breaking strength of the composite conductor.

#### 1.2.19.5.11.4. Electrical and Mechanical Requirements

The below given table provides OPGW Electrical and Mechanical Requirements for the minimum performance characteristics. Additionally, the OPGW mechanical & electrical characteristics shall be similar to that of the earth wire being replaced such that there is no or minimal consequential increase in stresses on towers. For the purposes of determining the appropriate Max Working Tension limit for the OPGW cable IS 802:1995 and IS 875: 1987 shall be applied. However the OPGW installation sag & tension charts shall be based on IS 802 version to which the line is originally designed. For the OPGW cable design selection and preparation of sag tension charts, the limits specified in this section shall also be satisfied. The Bidder shall submit sag-tension charts for the above cases with their bids.

1	Everyday Tension	≤ 20% of UTS of OPGW
2	D.C. Resistance at 20°C:	< 1.0 ohm/Km
3	Short Circuit Current:	≥ 6.32 kA for 1.0 second
4	Ultimate Tensile Strength (UTS)	The following parameters of the existing earth wire also shall be considered for UTS design
4a	Outer diameter (220/110KV)	10.98/9.75 mm

## Volume- II

---

4b	UTS (220/110KV)	68.4/56.02 KN
4c	Weight per Km (220/110KV)	583/428 Kgs

*Table 73: OPGW Electrical & Mechanical Requirements*

### **1.2.19.5.11.5 Operating conditions**

Since OPGW shall be located at the top of the EHV transmission line support structure, it will be subjected to Aeolian vibration, Galloping and Lightning strikes. It will also carry ground fault currents. Therefore, its electrical and mechanical properties shall be same or similar as those required of conventional ground conductors.

### **1.2.19.5.11.6 Installation**

OPGW installed under live line condition normally, i.e. with all circuits charged to the rated line voltage as specified in this section shall be generally in accordance with the IEEE Guide to the Installation of Overhead Transmission Line Conductors (IEEE STD. 524 with latest revisions), with additional instructions and precautions for live line working and fibre optic cable handling. The stringing procedure shall be submitted by the SI prior to stringing for Authority's approval.

In case earth wire is not available in certain spans or earth wire is broken during live line installation the SI has to install the OPGW in shunt down condition after taking permit from KSEBL. SI shall inform the Authority of any such cases.

For new Transmission lines the SI shall lay the OPGW cable after installation of towers by the Transmission line SI.

The OPGW cable sections shall normally be terminated & spliced only on tension towers. In exceptional circumstances, and on KSEBL specific approval, cable may be terminated on Suspension towers, but in this case tower strength shall be examined to ensure that tower loads are within safe limits and if required, necessary tower strengthening shall be carried out by the SI.

### **1.2.19.5.12. Installation Hardware**

The scope of supply of the optical cable includes the assessment, supply and installation of all required fittings and hardware such as Tension assembly, Suspension assembly, Vibration dampers, Reinforcing rods, Earthing clamps, Down lead clamps, splice enclosure etc. The Bidder shall provide documentation justifying the adequacy and suitability of the hardware supplied. The SI shall determine the exact requirements of all accessories required to install and secure the OPGW.

The OPGW hardware fittings and accessories shall follow the general requirements regarding design, materials, dimensions & tolerances, protection against corrosion and markings as specified in clause 4.0 of EN 61284: 1997 (IEC 61284). The shear strength of all bolts shall be at least 1.5 times the maximum installation torque. The OPGW hardware & accessories drawing & Data Requirement Sheets (DRS) document shall consist of three parts:

1. A technical particulars sheet
2. An assembly drawing i.e. level 1 drawing and
3. Component level drawings i.e. level 2 & lower drawings. All component reference numbers, dimensions and tolerances, bolt tightening torques & shear strength and ratings such as UTS, slip strength etc shall be marked on the drawings.

## Volume- II

---

The fittings and accessories described herein are indicative of installation hardware typically used for OPGW installations and shall not necessarily be limited to the following:

- a) **Suspension Assemblies:** Armoured grip suspension clamps and aluminium alloy armour rods/reinforcing rods shall be used. The suspension clamps shall be designed to carry a vertical load of not less than 25 kN. The suspension clamps slippage shall occur between 12kN and 17 kN as measured in accordance with type test procedures.  
  
The SI shall supply all the components of the suspension assembly including shackles, bolts, nuts, washers, split pins, etc. The total drop of the suspension assembly shall not exceed 150 mm (measured from the centre point of attachment to the centre point of the OPGW). The design of the assembly shall be such that the direction of run of the OPGW shall be the same as that of the conductor.
- b) **Dead End Clamp Assemblies:** Dead end clamp assemblies shall preferably be of performed armoured grip type and shall include all necessary hardware for attaching the assembly to the tower strain plates. Dead end clamps shall allow the OPGW to pass through continuously without cable cutting. The slip strength shall be rated not less than 95% of the rated tensile strength of the OPGW.
- c) **Clamp Assembly Earthing Wire:** Earthing wire consisting of a 1500 mm length of aluminium or aluminium alloy conductor equivalent in size to the OPGW shall be used to earth suspension and dead end clamp assemblies to the tower structure. The earthing wire shall be permanently fitted with lugs at each end. The lugs shall be attached to the clamp assembly at one end and the tower structure at the other.
- d) **Structure Attachment Clamp Assemblies:** Clamps used to attach the OPGW to the structures, shall have two parallel grooves for the OPGW, one on either side of the connecting bolt. The clamps shall be such that clamping characteristics do not alter adversely when only one OPGW is installed. The tower attachment plates shall locate the OPGW on the inside of the tower and shall be attached directly to the tower legs/cross-members without drilling or any other structural modifications.
- e) **Vibration Dampers:** Vibration dampers type 4R Stockbridge or equivalent, having four (4) different frequencies spread within the Aeolian frequency bandwidth, shall be used for suspension and tension points in each span. The SI shall determine the exact numbers and placement(s) of vibration dampers through a detailed vibration analysis as specified in technical specifications. Vibration damper clamps shall be made of aluminium or aluminium alloy, shall support the dampers during installation and shall maintain the dampers in position without damage to the OPGW and without causing fatigue. Armour or patch rods made of aluminium or aluminium alloy shall be provided as required to reduce clamping stress on the OPGW. The vibration damper body shall be hot-dip galvanised mild steel/cast iron or shall be permanent mould cast zinc alloy.

### 1.2.19.5.13. Fibre Optic Splice Enclosures (Joint Box)

All splices shall be encased in Fibre Optic Splice Enclosures. Suitable splice enclosures shall be provided to encase the optical cable splices in protective, moisture and dust free environment. Splice enclosures shall comply with ingress protection class IP 66 or better. The splice enclosures shall be designed for the storage and protection of required number of optical fibre splices and equipped with sufficient number of splice trays for splicing all fibres in the cable. Not more than 12 fibres shall be terminated in a single splice tray. They shall be filled with suitable encapsulate that is easily removable should re-entry be required into the enclosures.

Splice enclosures shall be suitable for outdoor use with each of the cable types provided under this contract. Splice enclosures shall be appropriate for mounting on transmission line towers above anti climb guard levels at about 10m

## Volume- II

---

from top of the tower and shall accommodate pass-through splicing. The actual mounting height and location shall be finalized after survey. SI shall be responsible for splicing of fibres and installation of splice enclosures.

In addition to the cable entry for OPGW, there shall be minimum two numbers of additional cable entries for 12mm dia.

### **1.2.19.6. Optical Fibre Splices**

Splicing of the optical fibre cabling shall be minimized through careful SI planning. There shall be no mid-span splices allowed. All required splices shall be planned to occur on tower structures.

All optical fibre splicing shall comply with the following:

- a) All fibre splices shall be accomplished through fusion splicing.
- b) Each fibre splice shall be fitted with a splice protection sheath fitted over the final splice.
- c) All splices and bare fibre shall be neatly installed in covered splice trays. Not more than twelve (12) fibres shall be installed in each splice tray.
- d) For each link, bi-directional attenuation of single mode fusion splices, shall not be more than 0.05 dB (average) and no single splice loss shall exceed 0.1 dB when measured at 1550 nm.
- e) For splicing, fibre optic cable service loops of adequate length shall be provided so that all splices occurring at tower structures can be performed at ground level.

### **1.2.19.7. Fibre Optic Distribution Panel**

At each location requiring the termination of at least one fibre within a cable, all fibres within that cable shall be connectorized and terminated in Fibre Optic Distribution Panels in a manner consistent with the following:

- a) All fibre optic terminations shall be housed using FODPs provisioned with splice organizers and splice trays. All fibres within a cable shall be fusion spliced to pre-connectorized pigtails and fitted to the "Back-side" of the provided fibre optic couplings.
- b) FODPs shall be suitable for use with each of the cable types provided as part of this contract. FODPs shall accommodate pass-through splicing and fibre terminations.
- c) FODPs for indoor use shall be supplied in suitable cabinets/racks with locking arrangement
- d) All FODPs shall be of corrosion resistant, robust construction and shall allow both top or bottom entry for access to the splice trays. Ground lugs shall be provided on all FODPs and the SI shall ensure that all FODPs are properly grounded. The FODP shall meet or exceed ingress protection class IP55 specifications.
- e) Flexible protection shall be provided to the patch cord bunches going out from FODP to other equipment.
- f) All patch cords and pigtails supplied along with FODP shall match with the characteristics of fibres provided in the DWDM OPGW cable.
- g) Minimum number of cable entry shall be 8 numbers.

- h) At each station 24 fibres shall be terminated at the FODP procured under Package A (at pre-fabricated shelter) and remaining 24 fibres at the FODP procured under Package B (KSEBL communication /control room).

### **1.2.19.8. Optical Fibre Termination and Splicing**

Optical fibre terminations shall be done in Fibre Optic Distribution Panels (FODP) designed to provide protection for fibre splicing of pre-connectorized pigtails and to accommodate connectorized termination and coupling of the fibre cables. The SI shall provide rack /wall mounted Fibre Optic Distribution Panels (FODPs) sized as per the site condition and shall terminate the fibre optic cabling up to the FODPs. The location of FODP rack (under Package B) shall be fixed by the SI, with the KSEBL's approval.

### **1.2.19.9. Optical Fibre Connectors**

Optical fibres shall be connectorised with FC-PC type connectors preferably. Alternatively connector with matching patch cord shall also be acceptable. Fibre optic couplings supplied with FODPs shall be appropriate for the fibre connectors to be supported. There shall be no adapters.

### **1.2.19.10. Service Loops**

For purposes of this specification, cable and fibre service loops are defined as slack (extra) cable and fibre provided for facilitating the installation, maintenance and repair of the optical fibre cable plant.

- a) Outdoor Cable Service Loops: In-line splice enclosures installed outdoors and mounted on the utility towers, shall be installed with sufficient fibre optic cable service loops such that the recommended minimum bend radius is maintained while allowing for installation or maintenance of the cable to be performed in a controlled environment at ground level.
- b) Indoor Cable Service Loops: FODPs shall provide at least three (3) metres of cable service loop. Service loops shall be neatly secured and stored, coiled such that the minimum recommended bend radius are maintained.
- c) Fibre Units Service Loops: For all fibre optic cable splicing, the cable shall be stripped back a sufficient length such that the fan-out of fibre units shall provide for at least one (1) metre of fibre unit service loop between the stripped cable and the bare fibre fan-out.
- d) Pigtail Service Loops: Connectorized pigtails spliced to bare fibres shall provide at least 1 metre of service loop installed in the FODP fibre organizer and at least one (1) metre of service loop to the couplings neatly stored behind the FODP coupling panels.
- e) Fibre Service Loops: At least 0.5 metre of bare fibre service loop shall be provided on each side of all fibre splices. The bare fibre service loops shall be neatly and safely installed inside covered splice trays.

### **1.2.19.11. Methodology for Installation and Termination**

All optical fibre cable termination, installation, stringing and handling plans, guides and procedures, and engineering analysis (e.g. tension, sag, vibration etc.) shall be submitted to the Authority for review and approval in the engineering/design phase of the project, prior to establishing the final cable lengths for manufacture. Installation procedures including details of personnel and time required shall be documented in detail and submitted to Authority for approval. All installation practices shall be field proven and ISO accredited.

All cable segments shall include service loops as specified in this specification. The maximum allowable stringing tension, maximum allowable torsional shear stress, crush strength and other physical parameters of the cable shall not exceed the limits. The preventative measures to be taken shall be documented in detail and submitted to Authority in advance of installation.

Optical fibre attenuation shall be measured after installation and before splicing. Any increase in attenuation or step discontinuity in attenuation shall not be acceptable and shall constitute a cable segment failure. In the event of cable damage or any fibre damage, the complete section (tension location to tension location) shall be replaced as mid-span joints are not acceptable.

Any or all additional steel work or modifications required to attach the fibre cabling to the overhead transmission/distribution line towers shall also be carried out by the SI. It shall be the SIs responsibility to provide adequate communications among all crew members and support staff to ensure safe and successful installations.

### **1.2.19.12. Fibre Optic Approach cables and its accessories**

#### **1.2.19.12.1 Fibre Optic Approach Cables**

For purposes of this specification, a fibre optic approach cable is defined as the Armoured (non-metallic) underground fibre optic cable required to connect Overhead Fibre Optic Cable (OPGW) between the final in line splice enclosure on the gantry / tower forming the termination of the fibre cable on the power line and the Fibre Optic Distribution Panel (FODP) installed within the building. The estimated fibre optic approach cabling length per station is around 250m. However, the SI shall supply & install the optical fibre approach cable as required based on detailed site survey to be carried out by the SI during the project execution and the Contract price shall be adjusted accordingly.

From the final in line splice enclosure in the tower/line two numbers of approach cable shall be laid, one to the FODP in KSEBL communication /control room and the other to FODP in the KFON pre-fabricated shelter

#### **1.2.19.12.2 Applicable Standards**

The cable shall conform to the standards named below and the technical specifications described in the following sections

- a) ITU-T Recommendations G. 652
- b) Electronic Industries Association, EIA/TIA 455-78A, 455-3A, 455-62A, 455-164A/167A/174, 455-168A/169A/175A, 455-176, 455-59, EIA/TIA 598, EIA 455-104.
- c) International Electro technical Commission standards, IEC60304, IEC60794-1-2, IEC60811-5-1
- d) Bellcore GR-20
- e) Telecom Engineering Centre (TEC), Department of Telecom, Govt. of India(TEC-spec no-GR/OFC-17/01, June 2007)

### **Optical Fibre Characteristics of the approach cable is same as that of OPGW cable**

#### **1.2.19.12.3 General Cable Construction**

The Optical cable shall consist of a central fibre optic unit protected by one or more layers of helically wound anti-hygroscopic tape or yarn. The central fibre optic unit shall be designed to house and protect the fibres from damage due to forces such as crushing, bending, twisting, tensile stress and moisture, wide temperature variations, hydrogen evolution etc. The fibre optic unit shall be of loose tube construction. The inner polyethylene jacket and outer sheath jackets shall be free from pinholes, joints, splits or any other defects. All fibre optic cable shall have a minimum service life span of 25 years. Documentary evidence in support of guaranteed life span of cable & fibre shall be submitted by the SI during detailed engineering.



### **1.2.19.12.4 Colour coding and Fibre Identification**

Individual optical fibres within a fibre unit, and fibre units shall be identifiable in accordance with EIA/TIA 598 of IEC 60304 or Bellcore GR-20 colour-coding scheme. The colour coding system shall be discernible throughout the design life of the cable. Colouring utilized for colour coding optical fibres shall be integrated into the fibre coating and shall be homogenous. The colour shall not bleed from one fibre to another and shall not fade during fibre preparation for termination of splicing. Each cable shall have traceability of each fibre back to the original fibre manufacturer's fibre number and parameters of the fibre. If more than the specified number of fibres are included in any cable, the spare fibres shall be tested by the cable manufacturer and any defective fibre shall be suitably bundled, tagged, and identified at the factory. The colouring scheme shall be submitted along with the cable DRS/drawing for Authority's approval.

### **1.2.19.12.5 Strength Members**

The central fibre optic unit should include a central strength member of Fibre Reinforced Plastic (FRP) or other suitable material. Peripheral strength members and aramid yarns are also acceptable. The central FRP strength member may be slotted type with SZ lay (reverse oscillation lay) of fibre units or it may be cylindrical type with helical lay of fibre units.

### **1.2.19.12.6 Filling Compound**

The interstices of the central fibre optic unit and cable shall be filled with a suitable compound to prohibit any moisture ingress or any longitudinal water migration within the fibre optic unit or along the fibre optic cable. The water tightness of the cable shall meet or exceed the test performance criteria as per IEC60794-1-2-F5. The filling compound used shall be a non-toxic homogenous waterproofing compound that is free of dirt and foreign matter, anti-hygroscopic, electrically nonconductive and non-nutritive to fungus. The compound shall also be fully compatible with all cable components it may come in contact with and shall inhibit the generation of hydrogen within the cable. The filling compound shall remain stable for ambient temperature up to +70°C and shall not drip, flow or leak with age or at change of temperature. Reference method to measure drip point shall be as per IEC 60811-5-1 and drip point shall not be less than 70°C.

### **1.2.19.12.7 The Sheath / Inner jacket**

The sheath shall be black, smooth, concentric, and shall be free from holes, splits, blisters and other surface flaws. The sheath shall be extruded directly over the central fibre optic unit and shall also be non-hygroscopic. The cable sheath design shall permit easy removal without damage to the optical fibres or fibre units. The sheath shall be made from good quality of weather resistant polyethylene compound (Black High Density Polyethylene- HDPE) and thickness shall be  $\geq 1.8\text{mm}$ .

### **1.2.19.12.8 Outer Jacket Construction & Material**

The Approach Cable shall be a UV resistant, rodent proof, termite proof, with non-metallic type of armouring. The outer cable jacket for approach cable shall consist of carbon black polyethylene resin to prevent damage from exposure to ultra-violet light, weathering and high levels of pollution. The jacket shall conform to ASTM D1248 for density.

### **1.2.19.12.9 Rip Cord**

Suitable rip cord(s) shall be provided to open the outer sheath of the cable. The rip cord(s) shall be properly waxed to prevent wicking action and shall not work as a water carrier.

### **1.2.19.12.10 Mechanical Parameters & Tests**

The offered cable shall meet requirement of mechanical characteristic & tests specified in latest TEC specifications.



### **1.2.19.12.1 Installation of approach cable**

The existing cable trenches / cable raceways proposed to be used shall be identified in the survey report. The SI shall make its best effort to route the cable through the existing available cable trenches. Where suitable existing cable trenches are not available, suitable alternative shall be provided after KSEBL's approval. However the approach cable shall be laid through the HDPE pipe in the all conditions. All required fittings supports, accessories, ducts, conduits, couplers and any item not specially mentioned but required for laying and installation of approach cable shall be supplied and installed by the SI.

### **1.2.19.13. PLB HDPE Pipe & Accessories**

The following paragraphs describe the functional requirements, major technical parameters for Permanently Lubricant High Density Polyethylene (PLB HDPE) Pipe. PLB HDPE pipe shall be suitable for underground fibre optic cable installation by blowing as well as conventional pulling. The PLB HDPE pipe shall be suitable for laying in trenches by directly burying, laying through G.I/RCC pipe and laying through trench less digging. The expected service life of HDPE pipe and accessories shall not be less than 25 years. The unit rates quoted in the price schedule shall be the composite price of PLB HDPE pipe along with all accessories.

#### **1.2.19.13.1 Construction of PLB HDPE pipe**

The PLB HDPE pipe shall have two concentric layers viz. outer layer and inner layer. The outer layer shall be made of HDPE material and the inner layer of solid permanent lubricant. These concentric layers shall be co-extruded and distinctively visible in cross-section under normal lighting conditions and generally conform to IS-9938. The colour of the PLB HDPE pipe shall be finalized during detail engineering. In the finished PLB HDPE pipe, the co-extruded inner layer of solid permanent lubricant shall be continuous and integral part with HDPE outer layer and preferably be white in colour. The inner layer of solid permanent lubricant shall not come out during storage, usage and throughout the life of the pipe.

The finished pipe shall be of good workmanship such that the pipe is free from blisters, shrink holes, flaking, chips, scratches, roughness, break and other defects. The pipe shall be smooth, clean and in round shape, without eccentricity. The ends shall be cleanly cut and shall be square with axis of the pipe.

#### **1.2.19.13.2 General**

The HDPE pipe shall conform to the following standard and the technical specifications described in the following sections.

- a) IS: 4984 / IS: 2530/IS:14151/(part1)/ IS:9938/IS:7328/IS12235(Part-9)/ IS:5175
- b) ASTM D 1693/ ASTM D 638/ ASTM D 648/ ASTM D 790 / ASTM D 1712/ ASTM D 2240/ ASTM D 4565 / ASTM F 2160/ ASTM G 154
- c) TEC-spec no. GR/CDS-08/02/NOV-04(including all amendments)-HDPE pipe for use as duct for optical fibre cable.
- d) The Ducts shall be in Grey colour and have the identification markings as per TEC GR wherein Authority logo shall be marked as Authority's name. (Ducts laid under Package B shall bear the name/logo of KSEBL)

#### **1.2.19.13.3 Material**

The raw material used for the PLB HDPE pipe shall meet the following requirements:

- i. The anti-oxidant establishes, color master batch and other additive used shall be physiologically harmless and shall be used only to minimum extent necessary to meet the specification.
- ii. Usage of any additives used separately or together, should not impair the long- term physical and chemical properties of the PLB HDPE pipe.
- iii. Suitable Ultra Violet stabilizers may be used for manufacture of the PLB HDPE pipe to protect against UV degradation when stored in open for a minimum period of 8 months.
- iv. The ash content of the colour master batch shall not be more than 12% when tested as per method detailed below:

## Volume- II

---

- a) Test Method for ash content: About one gram of the sample under test shall be taken and dried at 105°C for two hours in a platinum or glazed porcelain or silica or quartz crucible. The weight of the sample shall be noted. Subsequently, the sample with the crucible shall be transferred to a muffle furnace maintained at 600±50°C and allowed to remain there for three hours. The ash content may be calculated as a percentage of the weight of the original sample.
- v. The base HDPE resin used for manufacturing outer layer of pipe shall conform to any grade of IS-7328 or to any equivalent standard meeting the following requirement when tested as per standards referred in this Section below.
  - a) Density (outer and inner layer): 940 to 958kg/m<sup>3</sup> at 27°C. The density of completed PLB HDPE shall not be differ by more than 0.003gms/cc by this value when tested as per IS:2530 or IS:7328.
  - b) Melt Flow Rate (MFR): 0.2 to 1.1 g/10 minutes at 190°C & 5 kg load: when tested as per IS:2530. The MFR of the outer layer of the completed PLB HDPE pipe shall not differ by more than 30% of this value.
  - c) Tensile Strength at Yield: 20 N/mm<sup>2</sup> minimum, when tested As per ASTM D 638, Type-IV specimens
  - d) Elongation at break: >600%, when tested as per ASTM D638, Type-IV specimens
  - e) Flexural Modulus at 1% strain: 690 N/mm<sup>2</sup> minimum, when tested as per ASTM D 790.
  - f) Hardness, Shore-D: Between 60 and 65 units, when tested as per ASTM D 2240
  - g) Heat Deflection Temperature at 45 g/mm<sup>2</sup>: 65°C minimum, when tested as per ASTM D 648.
  - h) Environmental Stress Crack resistance, When tested with 10% Igepal, CO 0630 Solution 50°C: 96 hrs., when tested as per ASTM D 1693, No cracks.
  - i) Weathering in artificial (UV) light (Specimens shall be as per ASTM D 638 Type-IV) and cut from compression moulded sheet. After exposure for 720 hrs., Tensile strength shall be tested. The variation shall not be greater than 20% compared to tensile strength obtained at above.
  - j) UV Stabilizer Content: Hindered Amine Light Stabilizer minimum 0.15%, when analyzed as per FT-IR method.
  - k) In the inner layer of PLB HDPE pipe, the friction reducing, polymeric material to be used as the inner layer lubrication material shall be integral with HDPE layer. The lubricant materials shall have no toxic or dermatic hazards for safe handling.

### 1.2.19.13.4 Dimension of pipe

The nominal size of the pipe shall be 40mm and shall meet the following requirements.

- |                                       |   |   |
|---------------------------------------|---|---|
| a) Outside diameter                   | : | 40 mm + 0.4 mm  |
| b) Wall thickness                     | : | 3.5 mm (+0.2 mm/ -0.00 mm)  |
| c) Standard length                    | : | 1000 meters ± 100 meter   |
| d) Thickness of permanent lubricant   | : | >0.4 mm   |
| e) Maximum outer diameter of FO cable | : | 13.4±0.5 mm or cable dia whichever is that can be installed by blowing technique higher |

### 1.2.19.13.5 Accessories of PLB HDPE pipe

The following accessories are required for jointing the pipe and shall be supplied along with the pipe. The manufacturers shall provide complete design details, procedure for method of installation and type of the material used for the accessories. No part of the accessories shall contain metal part and minimum pulling force of the coupler shall be 330kgf. The accessories shall pass the ageing test at 70+2°C and there shall be no leakage when tested for 168 hours.

- 1) Plastic coupler: The coupler shall be used to join two PLB HDPE pipes. The coupling shall be able to provide a durable airtight and watertight joint between two pipes without deteriorating the strength of the pipes. The strength of coupler shall match the primary strength of the PLB HDPE pipe and threaded coupler is not

acceptable. The jointing shall meet the air pressure test of 15 kg/cm<sup>2</sup> for a minimum period of 2 hours without any leakage.

- 2) End plug: This shall be used for sealing the ends of empty pipe, prior to installation of FO cable and shall be fitted immediately after laying of the PLB HDPE pipe, to prevent entry of any unwanted elements such as dirt, water, moisture, insects/rodents etc.
- 3) Cable sealing plug: This is used to hold the cable and prevent entry of any unwanted elements, as specified above.
- 4) End cap: This cap is made of hard rubber, shall be fitted with both ends of PLB HDPE pipe to prevent the entry of any unwanted elements such as dirt, water, moisture, insects/rodents during transportation and storage.
- 5) PP Rope: This is optional and SI may use the same on need basis. The PP rope can be ordered along with the PLB duct as required. In this case PP ropes drawn through the HDPE/PLB pipes/coils and safely tied to the end caps at either ends with hooks to facilitate pulling of the Optical Fibre Cables at a later stage. The rope used is 3 strands Polypropylene Para Pro rope having yellow colour and size of 6 mm diameter. It should have a minimum breaking strength of 550 kg. The length of each coil of rope should be 5 meter more than the standard length of duct(or as ordered) and it should conform to (i) BS 4928 Part-II of 1974 (ii) IS 5175 of 1982. It should be of special grade and should have ISI certificate mark. It should be manufactured out of industrial quality Polypropylene.
- 6) Set of installation/maintenance accessories comprising of C-Spanners for tightening plastic coupler (4 nos.), Rotary duct cutter (2 nos.), spare cutting wheel (4 nos. per Rotary Duct cutter), Chamferring tool for giving slight chamfer to the ends of PLB HDPE pipe shall be used during maintenance of the PLB HDPE pipes and these items (1set) shall be supplied along with the pipe.

### 1.3. Data Requirement Sheet

#### 1.3.1 Data Requirements Sheets for Optical Fibre used in OPGW/ ADSS/ UG/ App Cable

Please provide detailed data sheets/manuals etc. as supporting documents

Make			
Model			
SL No.	Parameter	UoM	Guaranteed Value
1.	Optical Fibre		
2.	Type of fibre		
<b>Geometrical Characteristics</b>			
3.	Mode Field Diameter at 1310 nm		
4.	Cladding Diameter		
5.	Cladding non-circularity		
6.	Core Clad concentricity error		
7.	Protective Coating material Primary Secondary		
8.	Diameter Over Primary Coated with double UV cured acrylate		
9.	Protective Coating removal method		
10.	Coating/Cladding Concentricity		
<b>Transmission Characteristics</b>			
11.	Fibre Attenuation before Cabling		@ 1310 nm : Between 1285 and 1380 nm : Between 1390 and 1525 nm : @ 1550 nm: Between 1525 and 1625 nm :
12.	Water Peak Attenuation before Cabling		Between 1380 and 1390 nm :
13.	Fibre Attenuation After Cabling		@ 1310 nm : @ 1550 nm : @ 1625 nm :
14.	Water Peak Attenuation After Cabling		@ 1383 nm ± 3nm :
<b>Dispersion</b>			
15.	Total Dispersion		In 1285-1330 nm band: In 1270-1340 nm band: @1550 nm : @1625 nm :
16.	Polarization Mode Dispersion at 1310nm & 1550 nm		Fibre: Cabled Fibre:
17.	Zero Dispersion Wavelength		
18.	Zero Dispersion Slope		
19.	Cable Cut-off Wavelength for fibres used in cable		
20.	Cable Cut-off Wavelength		
<b>Mechanical Characteristics</b>			
21.	Proof Test for minimum strain level (Test method IEC 60793-1-30)		

**Volume- II**

<b>Make</b>			
<b>Model</b>			
<b>SL No.</b>	<b>Parameter</b>	<b>UoM</b>	<b>Guaranteed Value</b>
22.	Peak Stripability force to remove primary coating of the fibre (Test Method IEC 60793-1-32)		
23.	Dynamic Tensile Strength (Test Method IEC 60793-1-31)		for Un-aged for Aged
24.	Dynamic Fatigue (Test Method IEC 60793-1-33)		
25.	Static Fatigue (Test Method IEC 60793-1-33)		
26.	Fibre Micro Bend (Test Method FOTP-62/IEC 60793-1-47)		
A	Change in attenuation when fibre is coiled with 100 turns on 30 ± 1.0 mm diameter mandrel		@1550nm @1625nm
B	Change in attenuation when fibre is coiled with 1 turn around 32 ± 0.5 mm radius mandrel		@ 1550nm @ 1625nm
27.	Fibre Curl (Test Method IEC 60793-1-34)		
<b>Environment Characteristics</b>			
28.	Operating Temperature (Test Method IEC 60793-1-52) Temperature Dependence of Attenuation: Induced Attenuation at 1550 nm at -60 °C to +85 °C:		
29.	Temperature – Humidity Cycling (Test Method EIA/TIA-455-73) Induced Attenuation at 1550 nm at -10 °C to +85 °C		
30.	Water Immersion 23 °C (Test Method IEC 60793-1-53) Induced Attenuation at 1550 nm due to Water Immersion at 23 ± 2°C		
31.	Accelerated Aging (Temperature) 85°C (Test Method IEC 60793-1-51) Induced Attenuation at 1550 nm due to Temperature Aging at 85 ± 2°C		
32.	Retention of Coating Colour (Test method IEC-60793 – 1 - 51) Coated Fibre shall show no discernible change in color, when aged for relative humidity		
33.	Refractive Index		
34.	Refractive Index profile		
35.	Colour coding scheme		
36.	Colour coding material		

*Table 74: Data Requirement Sheet for optical fibre used in OPGW/ADSS/UG/Approach Cable*

**Volume- II**

**1.3.2 Data Requirement Sheet for 48F ADSS with 100 Kmph wind speed**

Make				
Model				
SL No.	Parameter	UoM	Guaranteed Value	
1.	TEC Compliant			
Installation and Operation Condition				
2.	Max Span length			
3.	Max Ice loading			
4.	Operational Wind Velocity			
5.	Sag of span length			
6.	Temperature Range			
OFC Construction Details				
7.	Tensile Strength			
8.	FRP Rod EAA coated			
9.	Tube ID(min)			
10.	Tube OD			
11.	48F		No.	Colour Schema
			Fibre per tube	
			No. of Loose tube	
12.	No. of dummy cord			
13.	Tube stranding layover strength			
14.	Min. Sheath Thickness		Inner: Outer:	
15.	Outer Sheath Colour			
16.	Aramid Quantity (Minimum)			
17.	Cable Diameter			
18.	Cable Weight			
19.	Fibre strain value used for cable design			
20.	Fibre strain value used for cable testing at defined load			
21.	Max. Tensile Strength			
22.	Minimum bending radius			

## Volume- II

Make			
Model			
SL No.	Parameter	UoM	Guaranteed Value
23.	Splice loss (Max & Min)		
24.	Expected Cable Life		
25.	Fibre cable drum length		

Table 75: Guaranteed Technical Particulars for 48F ADSS Cable with 100 Kmph wind speed

### 1.3.3 Data Requirement Sheet for 48F ADSS with 150 Kmph wind speed

Please provide detailed data sheets/manuals etc. as supporting documents

Make				
Model				
SL No.	Parameter	UoM	Guaranteed Value	
Installation and Operation Condition				
1.	Max Span length			
2.	Max Ice loading			
3.	Operational Wind Velocity			
4.	Sag of span length			
5.	Temperature Range			
OFC Construction Details				
6.	Tensile Strength			
7.	FRP Rod EAA coated			
8.	Tube ID(min)			
9.	Tube OD			
10.	48F		No.	Colour Schema
		Fibre per tube		
		No. of Loose tube		
11.	No. of dummy cord			
12.	Tube stranding layover strength			
13.	Min. Sheath Thickness		Inner: Outer:	
14.	Outer Sheath Colour			
15.	Aramid Quantity (Minimum)			

**Volume- II**

Make			
Model			
SL No.	Parameter	UoM	Guaranteed Value
16.	Cable Diameter		
17.	Cable Weight		
18.	Fibre strain value used for cable design		
19.	Fibre strain value used for cable testing at defined load		
20.	Max. Tensile Strength		
21.	Minimum bending radius		
22.	Splice loss (Max & Min)		
23.	Expected Cable Life		
24.	Fibre cable drum length		

*Table 76: Guaranteed Technical Particulars for 48F ADSS Cable with 150 kmph wind speed*

**1.3.4 Data Requirement Sheet for 24F ADSS with 100 Kmph wind speed**

Make				
Model				
SL No.	Parameter	UoM	Guaranteed Value	
1.	TEC Compliant		Yes/No	
Installation and Operation Condition				
2.	Max Span length			
3.	Max Ice loading			
4.	Operational Wind Velocity			
5.	Sag of span length			
6.	Temperature Range			
OFC Construction Details				
7.	Tensile Strength			
8.	FRP Rod EAA coated			
9.	Tube ID(min)			
10.	Tube OD			
11.	24F		No.	Colour Schema
			Fibre per tube	
			No. of Loose tube	



## Volume- II

Make			
Model			
SL No.	Parameter	UoM	Guaranteed Value
12.	No. of dummy cord		
13.	Tube stranding layover strength		
14.	Min. Sheath Thickness		Inner: Outer:
15.	Outer Sheath Colour		
16.	Aramid Quantity (Minimum)		
17.	Cable Diameter		
18.	Cable Weight		
19.	Fibre strain value used for cable design		
20.	Fibre strain value used for cable testing at defined load		
21.	Max. Tensile Strength		
22.	Minimum bending radius		
23.	Splice loss (Max & Min)		
24.	Expected Cable Life		
25.	Fibre cable drum length		

Table 77: Guaranteed Technical Particulars for 24F ADSS Cable with 100 kmph wind speed

### 1.3.5 Data Requirement Sheet for 12F ADSS with 100 Kmph wind speed

Make			
Model			
SL No.	Parameter	UoM	Guaranteed Value
1.	TEC Compliant		
Installation and Operation Condition			
2.	Max Span length		
3.	Max Ice loading		
4.	Operational Wind Velocity		
5.	Sag of span length		
6.	Temperature Range		
OFC Construction Details			
7.	Tensile Strength		

**Volume- II**

Make					
Model					
SL No.	Parameter	UoM	Guaranteed Value		
8.	FRP Rod EAA coated				
9.	Tube ID(min)				
10.	Tube OD				
11.	12F			No.	Colour Schema
			Fibre per tube		
			No. of Loose tube		
12.	No. of dummy cord				
13.	Tube stranding layover strength				
14.	Min. Sheath Thickness		Inner: Outer:		
15.	Outer Sheath Colour				
16.	Aramid Quantity (Minimum)				
17.	Cable Diameter				
18.	Cable Weight				
19.	Fibre strain value used for cable design				
20.	Fibre strain value used for cable testing at defined load				
21.	Max. Tensile Strength				
22.	Minimum bending radius				
23.	Splice loss (Max & Min)				
24.	Expected Cable Life				
25.	Fibre cable drum length				

*Table 78: Guaranteed Technical Particulars for 12F ADSS Cable with 100 Km/h wind speed*

**1.3.6 Data Requirement Sheet for Aerial Drop Cable**

Make			
Model			
SL No.	Parameter	UoM	Guaranteed Value
1.	TEC GR Compliant		Yes/No
2.	Optical Fibre		
3.	Type of fibre (wavelength band optimized nominal 1310 nm)		
4.	TEC Compliant		
Geometrical Characteristics			
5.	Mode Field Diameter for matched clad		
6.	Cladding Diameter		
7.	Cladding non-circularity		
8.	Core Clad concentricity error		
9.	Diameter Over Primary Coated with double UV cured acrylate (shall be measured on un-coloured fibre)		
10.	Coating/Cladding Concentricity		
Transmission Characteristics			
11.	Fibre Attenuation before Cabling		@ 1310 nm : Between 1285 and 1360 nm : Between 1360 and 1480 nm : Between 1480 and 1525 nm : @ 1550 nm : Between 1525 and 1625 nm : @ 1270 nm : @ 1490 nm : @ 1625 nm :
12.	Fibre Attenuation after Cabling		@ 1310 nm : @ 1550 nm : @ 1490 nm :
Dispersion			
13.	Total Dispersion		In 1285-1330 nm band: In 1270-1340 nm band: @1550 nm : @1625 nm :
14.	Polarization Mode Dispersion at 1310nm & 1550 nm		Fibre: Cabled Fibre: Link Design Value:
15.	Zero Dispersion Wavelength		

**Volume- II**

<b>Make</b>			
<b>Model</b>			
<b>SL No.</b>	<b>Parameter</b>	<b>UoM</b>	<b>Guaranteed Value</b>
16.	Zero Dispersion Slope		
17.	Fibre Cut-off Wavelength		
18.	Cable Cut-off Wavelength		
<b>Mechanical Characteristics</b>			
19.	Proof Test for minimum strain level (Test method IEC 60793-1-30)		
20.	Peak Stripability force to remove primary coating of the fibre (Test Method IEC 60793-1-32)		
21.	Dynamic Tensile Strength (Test Method IEC 60793-1-31)		Un-aged Aged
22.	Dynamic Fatigue (Test Method IEC 60793-1-33)		
23.	Static Fatigue (Test Method IEC 60793-1-33)		
24.	Fibre Micro Bend (Test Method FOTP-62/IEC 60793-1-47)		
A	Change in attenuation when fibre is coiled with 10 turns on 15 mm radius mandrel		@ 1550nm @ 1625nm
B	Change in attenuation when fibre is coiled with 1 turn around 10 mm radius mandrel		@ 1550nm @ 1625nm
25.	Fibre Curl (Test Method IEC 60793-1-34)		
<b>Environment Characteristics</b>			
26.	Operating Temperature (Test Method IEC 60793-1-52) Temperature Dependence of Attenuation: Induced Attenuation at 1550 nm at -60 °C to +85 °C:		
27.	Temperature – Humidity Cycling (Test Method EIA/TIA-455-73) Induced Attenuation at 1550 nm at -10 °C to +85 °C		
28.	Water Immersion 23 °C (Test Method IEC 60793-1-53) Induced Attenuation at 1550 nm due to Water Immersion at 23 ± 2°C		
29.	Accelerated Aging (Temperature) 85°C (Test Method IEC 60793-1-51) Induced Attenuation at 1550 nm due to Temperature Aging at 85 ± 2°C		

**Volume- II**

Make				
Model				
SL No.	Parameter	UoM	Guaranteed Value	
30.	Retention of Coating Colour(Test method IEC- 60793 – 1 - 51) Coated Fibre shall show no discernible change in colour, when aged for relative humidity			
Installation and Operation Condition				
31.	Max Span length			
32.	Max Ice loading			
33.	Operational Wind Velocity			
34.	Sag of span length			
35.	Temperature Range			
OFC Construction Details				
36.	4F		No.	Colour Schema
		Fibre per tube	4	BL,OR,GR, BR
		No. of Loose tube	1	Natural
37.	Tensile force design parameter			
38.	Loose Tube ID/OD			
39.	Loose Tube Material			
40.	Embedded Strength Material			
41.	Diameter of FRP			
42.	Aramid Yarns (Peripheral Strength Member)			
43.	Sheath Material			
44.	Sheath Colour			
45.	Min. Thickness of Sheath Material			
46.	Cable Weight			
47.	Cable Diameter			
Fibre Material Properties				
48.	Substances of which fibre are made of			
49.	Protective material requirement			

**Volume- II**

Make			
Model			
SL No.	Parameter	UoM	Guaranteed Value
I	The physical and chemical properties of the material used for the fibre primary coating		
ii	Coating and for single jacket fibre		
50.	The best way of removing protective coating material.		
51.	Group refractive Index of fibre		

*Table 79: Guaranteed Technical Particulars for Aerial Drop Cable*

**1.3.7 Data Requirements Sheets for ADSS Cable Accessories**

**1.3.7.1 Anchoring (Dead End Assembly)**

Make				
Model				
Sl. No.	Details	Specific Requirement	Compliance Yes/No	Pg. No in Supporting Doc.
1	Type of Clamp	Tension (Dead-end)		
2	Name and address of the Manufacturer			
3	Type of design	Wedge Type		
4	Cable Diameter Range of Clamp	As per cable design requirement		
5	Installation mode	Ready- to-use (Without disassembling). No specific tools required for cable installation. No loose parts allowed.		
6	Mounting	Provision to mount on Bracket and cross arm holes		
7	Type & Grade of the Material			
a.	Clamp Body	UV Resistant Thermoplastic / Aluminum		
b.	Wedge	UV Resistant Thermoplastic		
8	Minimum Breaking Load (in KN)	As per cable design requirement		
9	Marking	To be furnished by the vendor		
10	Dimension & Weight	Drawing to be submitted in the Tender		

*Table 80: Guaranteed Technical Particulars for Anchoring Assembly for ADSS Cable*

**1.3.7.8 Suspension Clamp Assembly**

Make				
Model				
Sl. No.	Details	Specific Requirement	Compliance Yes/No	Pg. No in Supporting Doc.
1	Type of Clamp	Suspension Clamp		
2	Name and address of the Manufacturer			
3	Type of design	Mounting clamp with Insert arrangement. Multiple orientation allowability.		
4	Cable Diameter Range	As per cable design requirement		
5	Mounting	Using Stainless Steel Strap or Bolts		
6	Type & Grade of the Material			
a.	Clamp Body	UV Resistant Thermoplastic		
b.	Insert	Elastomer		
7	Minimum Breaking Load (in KN)	As per cable design requirement		
8	Marking	To be furnished by the vendor		
9	Dimension & Weight	Drawing to be submitted in the Tender		

*Table 81: Guaranteed Technical Particulars for Suspension Assembly for ADSS Cable*

**1.3.7.9 Universal Pole Bracket (for Anchoring Assembly Mounting)**

Make				
Model				
Sl. No.	Details	Specific Requirement	Compliance Yes/No	Pg. No in Supporting Doc.
1	Name and address of the Manufacturer			
2	Type of design	6-Line Servicing		
3	Type and grade of metallic / non-metallic materials	Heat treated Aluminum alloy for bracket		
4	Manufacturing process	Gravity die casting		
5	Min. Ultimate tensile strength	Min 15 KN		

**Volume- II**

Make				
Model				
Sl. No.	Details	Specific Requirements	Compliance Yes/No	Pg. No in Supporting Doc.
6	Marking	To be furnished by the vendor		
7	Dimension & Weight	Drawing to be submitted in the Tender		

Table 82: Guaranteed Technical Particulars for Universal Pole Bracket for ADSS Cable

**1.3.7.Adjustable Cable Storage Bracket**

Make				
Model				
Sl. No.	Details	Specific Requirements	Compliance Yes/No	Pg. No in Supporting Doc.
1	Name and address of the Manufacturer			
2	Type of design	Pole mounting – Adjustable type for Coil		
3	Cable Loop Diameter Range	min 400 to 660mm		
4	Mounting	Using Stainless Steel Strap or Bolts		
5	Type & Grade of the Material			
a.	Bracket	Aluminum alloy		
b.	Sliding Pipes or Rod	Aluminum or Hot dip Galvanized Steel		
6	Minimum Breaking Load (in KN)	As per cable design requirement		
7	Marking	To be furnished by the vendor		
8	Dimension & Weight	Drawing to be submitted in the Tender		

Table 83: Guaranteed Technical Particulars for Adjustable Cable Storage Bracket for ADSS Cable



**1.3.7. Stainless Steel Strap and Buckle**

Make				
Model				
Sl. No.	Details	Specific Requirement	Compliance Yes/No	Pg. No in Supporting Doc.
<b>A</b>	<b>Steel Strap</b>			
1	Name and address of the Manufacturer			
2	Material composition	SS 202		
3	Tensile strength (kN)	Min 7.5		
4	Width of Strap	As per Drawing		
5	Thickness of Strap	As Per Drawing		
6	Length indication marking	Marking required at every 250mm		
7	General Marking engraved in the strap	Manufacturer name and date of marking		
8	Provision for easy and safe usage	To be provided in a thermoplastic dispenser casing with bobbin.		
9	Dimension & Weight	Drawing to be submitted in the Tender		
<b>B</b>	<b>Buckle</b>			
1	Material composition	SS 304		
2	Tensile strength (kN)	Min 7.5		
3	Dimension & Weight	Drawing to be submitted in the Tender		
4	Packing requirement	Supplied as a box of 100 nos each		

Table 84: Guaranteed Technical Particulars for Stainless Steel Strap & Buckle for ADSS Cable

**1.3.7. Down Lead Clamps**

Make				
Model				
Sl. No.	Details	Specific Requirement	Compliance Yes/No	Pg. No in Supporting Doc.
1	Name and address of the Manufacturer			

**Volume- II**

Make				
Model				
Sl. No.	Details	Specific Requirement	Compliance Yes/No	Pg. No in Supporting Doc.
2	Type & Grade of the Material	Pole Mounting & UV Resistant Thermoplastic		
3	Cable Diameter Range	As per cable design requirement		
9	Dimension & Weight	Drawing to be submitted in the Tender		

*Table 85: Guaranteed Technical Particulars for Down Lead Clamp for ADSS Cable*

**1.3.8 Data Requirement Sheet for Drop Cable Accessories**

**1.3.8.1 Anchoring (Dead End) Assembly**

Make				
Model				
Sl. No.	Details	Specific Requirement	Compliance Yes/No	Pg. No in Supporting Doc.
1	Type of Clamp	Anchoring (Dead-end)		
2	Name and address of the Manufacturer			
3	Type of design	Wedge Type		
4	Cable Diameter Range	5 – 7mm		
5	Installation mode	Ready- to-use (Without disassembling). No specific tools required for cable installation. No loose parts allowed.		
6	Mounting	Provision to mount on Bracket and cross arm holes		
7	Type & Grade of the Material			
A	Clamp Body	UV Resistant Thermoplastic		
B	Wedge	UV Resistant Thermoplastic		
8	Minimum Breaking Load (in KN)	As per cable design requirement		
9	Marking	To be furnished by the vendor		

**Volume- II**

Make				
Model				
Sl. No.	Details	Specific Requirements	Compliance Yes/No	Pg. No in Supporting Doc.
10	Dimension & Weight	Drawing to be submitted in the Tender		

*Table 86: Guaranteed Technical Particulars for Anchoring Assembly for Aerial drop cable*

**1.3.8.2 Suspension Clamp Assembly**

Make				
Model				
Sl. No.	Details	Specific Requirements	Compliance Yes/No	Pg. No in Supporting Doc.
1	Type of Clamp	Suspension Clamp		
2	Name and address of the Manufacturer			
3	Type of design	Mounting clamp with body having Multiple orientation allowability.		
3	Cable Diameter Range	5 – 7mm		
4	Mounting	Using Stainless Steel Strap or Bolts		
5	Type & Grade of the Material			
a	Clamp Body	UV Resistant Thermoplastic		
b	Cable Insert	UV Resistant Thermoplastic		
6	Minimum Breaking Load (in KN)	As per cable design requirement		
7	Marking	To be furnished by the vendor		
8	Dimension & Weight	Drawing to be submitted in the Tender		

*Table 87: Guaranteed Technical Particulars for Suspension Clamp Assembly for Aerial drop cable*

**1.3.8. Universal Pole Bracket (for Accessory Mounting)**

Make				
Model				
Sl No.	Details	Specific Requirements	Compliance Yes/No	Pg. No in Supporting Doc.
1	Name and address of the Manufacturer			
2	Type of design	Fixing through Strap or Nail		
3	Type and grade of metallic / non-metallic materials	UV Resistant Thermoplastic		
4	Manufacturing process	Injection Moulding		
5	Min. Ultimate tensile strength	Min 2 KN		
9	Marking	To be furnished by the vendor		
10	Dimension & Weight	Drawing to be submitted in the Tender		

Table 88: Guaranteed Technical Particulars for Universal Pole Bracket for Aerial drop cable

**1.3.8. Adjustable Cable Storage Bracket**

Make				
Model				
Sl No.	Details	Specific Requirements	Compliance Yes/No	Pg. No in Supporting Doc.
1	Name and address of the Manufacturer			
2	Type of design	Pole mounting – Adjustable type for Coil		
3	Cable Loop Diameter Range	For 5 – 7mm: 270 to 400mm		
4	Mounting	Using Stainless Steel Strap or Bolts		
5	Type & Grade of the Material			
	Bracket	Heat Treated Aluminum alloy		
	Sliding Pipes or Rod, Bolts, Nuts etc	Aluminum or Hot dip Galvanized Steel		

**Volume- II**

Make				
Model				
SI No.	Details	Specific Requirements	Compliance Yes/No	Pg. No in Supporting Doc.
6	Minimum Breaking Load (in KN)	As per cable design requirement		
7	Marking	To be furnished by the vendor		
8	Dimension & Weight	Drawing to be submitted in the Tender		

Table 89: Guaranteed Technical Particulars for Adjustable Cable Storage Bracket for Aerial drop cable

**1.3.8. Stainless Steel Strap and Buckle**

Make				
Model				
SI No.	Details	Specific Requirements	Compliance Yes/No	Pg. No in Supporting Doc.
<b>A</b>	<b>Steel Strap</b>			
1	Name and address of the Manufacturer			
2	Material composition	SS 202		
3	Tensile strength (kN)	Min 2.4 KN		
4	Width of Strap	> 10 mm		
5	Thickness of Strap	> 0.4 mm		
6	Length indication marking	Marking required at every 250mm		
7	General Marking engraved in the strap	Manufacturer name and date of marking		
8	Provision for easy and safe usage	To be provided in a thermoplastic dispenser casing with bobbin.		
9	Dimension & Weight	Drawing to be submitted in the Tender		
<b>B</b>	<b>Buckle</b>			
1	Material composition	SS 304		

**Volume- II**

Make				
Model				
Sl No.	Details	Specific Requirements	Compliance Yes/No	Pg. No in Supporting Doc.
2	Tensile strength (kN)	Min 2.4 KN		
3	Dimension & Weight	Drawing to be submitted in the Tender		
5	Packing requirement	Supplied as a box of 100 nos each		

Table 90: Guaranteed Technical Particulars for Stainless Strap & Buckle for Aerial drop cable

**1.3.8. Down Lead Clamps**

Make				
Model				
Sl. No.	Details	Specific Requirement	Compliance Yes/No	Pg. No in Supporting Doc.
1	Name and address of the Manufacturer			
2	Type & Grade of the Material	Pole Mounting & UV Resistant Thermoplastic		
3	Cable Diameter Range	As per cable design requirement		
9	Dimension & Weight	Drawing to be submitted in the Tender		

Table 91: Guaranteed Technical Particulars for Down Lead Clamp for Aerial drop cable

**1.3.9 Data Requirement Sheet for Overhead Fibre Optic Cable - OPGW**

Manufacturer:			
Model:			
Sl. No	Parameter	Units	Guaranteed Value
1	Fibre Manufacturer		
	Dual Window Single-Mode:		
2	No. of Fibres	each	
	Dual Window Single-Mode:		
3	Buffer Type		
4	Buffer Tube Diameter	mm	
5	Buffer Tube material		

**Volume- II**

<b>Manufacturer:</b>			
<b>Model:</b>			
<b>Sl. No</b>	<b>Parameter</b>	<b>Units</b>	<b>Guaranteed Value</b>
6	No. of Buffer Tubes	each	
7	No. of Fibres per Tube	each	
8	Identification/numbering of individual tubes		
9	No. of empty tubes (If any)		
10	Filling material		
11	Filling material compliant with technical specifications?		
12	Strength member(s)		
13	Binding yarn/ tape		
14	Describe Central Core Design		
15	Aluminum Clad steel wire	mm	
	Diameter	each	
	Number		
16	Aluminum Alloy wire	mm	
	Diameter	each	
	Number		
17	Aluminum tube inner diameter	mm	
18	Aluminum tube outside diameter	mm	
19	Cable Diameter (nominal $\pm$ deviation)	mm	
20	Cable cross-section area (Nominal)	mm <sup>2</sup>	
21	Cable cross-section area (Effective)	mm <sup>2</sup>	
22	Fully Compliant with IEEE 1138	Yes/No	
<b>Mechanical Properties of Cable</b>			
23	Max. breaking load/ Ultimate Tensile Strength (UTS)	kN	
24	Fibre strain margin	%	
25	Zero fibre strain up to load	kN	
26	Weight	kg/km	
27	Crush strength	kg/mm	
28	Equivalent Modulus of elasticity	KN/mm <sup>2</sup>	

**Volume- II**

<b>Manufacturer:</b>			
<b>Model:</b>			
<b>Sl. No</b>	<b>Parameter</b>	<b>Units</b>	<b>Guaranteed Value</b>
29	Minimum Bending Radius without microbending	mm	
30	Maximum Bending Radius:Short Term:Long Term (Continuous)	mm	
31	Tensile proof test (Screening) level	KN/mm <sup>2</sup>	
32	Maximum permissible tensile stress	KN/mm <sup>2</sup>	
33	Permissible CTS. tensile stress	KN/mm <sup>2</sup>	
34	Maximum sag at maximum temperature and design span with no wind	mm	
35	Everyday tension at 32°C, no wind	% of UTS	
36	Maximum tension at Every day condition with full wind pressure	Kg	
<b>Thermal Properties of Cable</b>			
37	Coefficient of linear expansion	per °C	
38	Coefficient of expansion		
	Cladding	per °C	
	Core	per °C	
39	Nominal operating temperature range	°C	
40	SC current transient peak temperature	°C	
41	Maximum allowable temperature for lightning strike	°C	
<b>CABLE SPOOL and DRUM</b>			
42	Available length per spool	m	
	Maximum		
	Nominal operating temperature range		
43	Size of drum	m	
44	Weight of empty drum	kg	
45	Weight of drum with cable spooled	kg	
46	Will drum length scheduling be practiced to match transmission line span lengths?	Yes/No	
47	Describe Drum materials		



**Volume- II**

<b>Manufacturer:</b>			
<b>Model:</b>			
<b>Sl. No</b>	<b>Parameter</b>	<b>Units</b>	<b>Guaranteed Value</b>
48	Describe cable end capping and protection against abrasion etc.		
<b>INSTALLATION</b>			
49	Splice Loss		
	Maximum	dB	
	Average	dB	
50	Operating Temperature Range	°C	
51	Rated Isoceraunic No.		
52	Expected Cable Life	Years	
53	Installation rate per team	km/day	
54	No. of persons per team	no.	
55	Max. possible span for specified operating conditions	M	
56	Midspan sag at 0°C with no wind loading	Mm	
57	Midspan sag at max temp. with no wind loading	Mm	
58	Midspan sag at max temp. and wind loading	Mm	
59	Cable swing angles		
	Worst Case		
	Everyday		
60	Describe Installation method(s)		
Sag tension chart parameters like sag and tension at various spans and applicable wind and ice load conditions shall be submitted along with the DRS. The cable parameters like coefficient of liner expansion, modulus of elasticity shall also be indicated.			

*Table 92: Guaranteed Technical Parameters for OPGW Cable*

**1.3.10 Data Requirement Sheet for OPGW Accessories**

Please provide supporting documents for the all the below items

**1.3.10.1. Suspension Clamp Assembly**

Manufacturer				
Model				
Sl. No.	Parameter	Unit	Particular	Pg. No in Supporting Doc.
1	Manufacturer			
2	Type			
3	Drawing No			
4	Minimum vertical Strength	kN		
5	Maximum Slip Strength	kN		
6	Minimum Slip Strength	kN		
7	Length (nominal)	mm		
8	Weight (nominal)	kg		
9	Total Drop (maximum) including shackles	mm		
10	Tightening torque (nominal)	Nm		
11	Details of Armour Rod Set			
	No. of rods per clamp			
	Direction of Lay			
	Overall length	mm		
	Diameter of each Rod	mm		
	Tolerances	±%		
	Diameter of each rod	±%		
	Length of each rod			
	Material of manufacture			
	UTS of each Rod	kN		
Weight	kg			
12	Details of Protection Splice Set (Reinforcing Rods)			
	No. of rods per clamp			
	Direction of Lay			
	Overall length	mm		

Manufacturer				
Model				
Sl. No.	Parameter	Unit	Particular	Pg. No in Supporting Doc.
	Diameter of each Rod	mm		
	Tolerances	±%		
	Diameter of each rod	±%		
	Length of each			
	Material of manufacture			
	UTS of each Rod	kN		
	Weight	kg		

*Table 93: Guaranteed Technical Particulars for Suspension Clamp Assembly*

**1.3.10.2. Dead End Clamp Assembly**

<b>Manufacturer</b>				
<b>Model</b>				
<b>Sl. No.</b>	<b>Parameter</b>	<b>Unit</b>	<b>Particulars</b>	<b>Pg. No in Supporting Doc.</b>
1	Manufacturer			
2	Type			
3	Drawing No			
4	Minimum Slip Load	kN (95% of OPGW UTS)		
5	Length (nominal)			
	Reinforcing Rods	mm		
	Dead End	mm		
6	Weight (nominal)			
	Reinforcing Rods	kg		
	Dead End	kg		
7	Breaking Strength (minimum)	kN		
8	Wire Size			
	Reinforcing Rods	mm		
	Dead End	mm		

*Table 94: Guaranteed Technical Particulars for Dead End Clamp Assembly*

**1.3.10.3. Vibration Dampers**

Make				
Model				
Sl. No.	Parameter	Unit	Particulars	Pg. No in Supporting Doc.
1	Manufacturer			
2	Type			
3	Drawing No			
4	Total Weight	Kg		
5	Weight of each Damper			
6	Material of Damper Weight			
7	Clamp Material			
8	Clamp bolt tightening torque	Nm		
9	Clamp bolt material			
10	Messenger Cable Material			
	No. of Strands in Messenger Cable			
	Breaking Strength of Messenger Cable	kN		
11	Resonance Frequencies			
	First Frequency	Hz		
	Second Frequency	Hz		
	Third Frequency	Hz		
	Forth Frequency	Hz		
12	Minimum Slip Strength of Damper Clamp			
	a) Before Fatigue Test	kN		
	b) After fatigue Test	kN		

*Table 95: Guaranteed Technical Particulars for Vibration Dampers*

**1.3.10.4. Down Lead Clamp/ Fastening Clamp**

Make				
Model				
Sl. No.	Parameter	Unit	Particulars	Pg. No in Supporting Doc.
1	Manufacturer			
2	Type			
3	Drawing No			
4	Material:			
5	Suitable for OPGW (range)	mm		
6	Tightening torques	Nm		
7	Vertical load	kN		
8	Filler details			
	Material	mm		
	Diameter	mm		
9	Tower attachment arrangement			

*Table 96: Guaranteed Technical Particulars for Down Lead Clamp*

**1.3.10.5. Earth Lead Assembly**

Make				
Model				
Sl. No.	Parameter	Unit	Particulars	Pg. No in Supporting Doc.
1	Manufacturer			
2	Type			
3	Drawing No			
4	Weight	kg		
5	Material			
6	length	mm		
7	Short circuit current	KA		

*Table 97: Guaranteed Technical Particulars for Earth Lead Assembly*

**1.3.10.6. Parallel Groove Clamp**

Make				
Model				
Sl. No.	Parameter	Unit	Particulars	Pg. No in Supporting Doc.
1	Manufacturer			
2	Type			
3	Drawing No			
4	Weight	kg		
5	Material			
6	length	mm		
7	Short circuit current	KA		

*Table 98: Guaranteed Technical Particulars for Parallel Groove Clamp*

**1.3.10.7. Inline Splice Enclosures (Joint Boxes)**

Make				
Model				
SI No.	Parameter	Unit	Particulars	Pg. No in Supporting Doc.
1	Manufacturer			
2	Type			
3	Drawing No			
4	Dimensions H * W * D :	cm		
5	Weight :	Kg		
6	Colour and Finish :			
7	Cable Glanding & Fixing			
8	Construction materials & Gauge			
9	Locking arrangements :			
8	IP Protection	Class		
9	Whether filled with suitable encapsulant	Yes/No		
10	Method(s) for mounting with the tower :			
Optical Fibre Cable Accommodations				
13	Cable Glanding :			
14	Maximum number of cables that can be accommodated (2 numbers OPGW +2 no. ADSS cable)	No.		
15	Diameter(s) of cables that can be accommodated :	each		
16	Describe Cable entries :			
Cable Termination Splice Accommodations				
17	Details of Splice Trays :			
	Dimension :			
	Material/Gauge :			
	Weight :	kg		
	Colour & Finish			
	Method of mounting :			
18	Number of splice trays available :			



**Volume- II**

Make				
Model				
Sl No.	Parameter	Unit	Particulars	Pg. No in Supporting Doc.
19	Total number of optical couplings :			
20	Provision of pass through splicing :	Yes/No		
21	Excess length of fibre service loops and provision for coiling / arranging			

*Table 9: Guaranteed Technical Particulars for Inline Joint Enclosures*

**1.3.10.8. Free Standing Cubicle & Wall Mountable Type - FODP**

Manufacturer				
Model				
Sl. No.	Parameter	Unit	Particulars	Pg. No in Supporting Doc.
1	Dimensions H * W * D :	cm		
2	Weight :	kg		
3	Colour and Finish :			
4	Cable Glanding & Fixing :			
5	Construction materials & Gauge			
6	Locking arrangements			
7	Installation Clearances:	cm		
	Front Access			
	Rear Access			
	Top * Bottom * Sides			
8	IP Protection	Class		
9	Whether filled with suitable encapsulant	Yes/No		
10	Method(s) for floor mounting			
Optical Fibre Cable Accommodations				
13	Cable Glanding :			
14	Maximum number of cables that can be accommodated :			
15	Diameter(s) of cables that can be accommodated :	each		
16	Describe Cable entries :			

**Volume- II**

<b>Manufacturer</b>				
<b>Model</b>				
<b>Sl. No.</b>	<b>Parameter</b>	<b>Unit</b>	<b>Particulars</b>	<b>Pg. No in Supporting Doc.</b>
Cable Termination Splice Accomodations				
17	Details of Splice Trays :			
	Dimension :			
	Material/Gauge :			
	Weight :	kg		
	Colour & Finish			
	Tray Type			
	Method of mounting			
	Number of splice trays available	No		
	Type of Adapter			
	Details of Pig tail			
	Number of splices per tray	No		
	Provision of Splice organizers			
18	Do splice trays require a separate enclosure? If so	Yes/No		
19	Manufacturer			
20	Dimensions H * W * D	cm		
21	Weight	Kg		
22	Colour and Finish			
23	Construction materials & Gauge			
24	Method(s) of Mounting			
25	Locking arrangements			
26	Excess length of fibre service loops and provision for coiling / arranging	m		

*Table 100: Guaranteed Technical Particulars for FODP*



**1.3.1 Data Requirements Sheet for Approach Cable /UG Cable**

Please provide detailed data sheets/manuals etc. as supporting documents

<b>Manufacturer:</b>			
<b>Model:</b>			
<b>Sl. No.</b>	<b>Parameter</b>	<b>Unit</b>	<b>Guaranteed Value</b>
<b>Cable Construction &amp; Mechanical Parameters</b>			
1	No. of fibres in the cable		
2	Type of fibres		
3	Cable diameter		
	nominal	mm	
	tolerance	mm	
4	Cable weight	Kg/ km	
5	Max Tensile Strength	KN	
6	Max pulling tension		
	During installation	KN	
	During Service	KN	
7	Minimum bending radius	mm	
	During installation	mm	
	During service		
8	Maximum continuous length	Km	
9	Temperature range		
	Operation	°C	
	Installation	°C	
	Shipping &Storage	°C	
10	Crush strength	KN/M2	
11	Impact resistance		
12	Torsion resistance		
13	Outer jacket thickness		
	Nominal	mm	
	Tolerance	mm	
14	Outer jacket material		

**Volume- II**

<b>Manufacturer:</b>			
<b>Model:</b>			
<b>Sl. No.</b>	<b>Parameter</b>	<b>Unit</b>	<b>Guaranteed Value</b>
15	Description of outer jacket coatings/ additives (eg. For Fire retardant treatment, anti-rodent, ant termite measures etc.)		
16	Inner jacket material		
17	Inner jacket thickness		
18	Inner jacket coatings/ additives/ treatment		
19	Describe cable core binding arrangement (tape or yarn, lay directions, pitch etc.)		
20	Central strength members description		
	Material		
	Diameter	mm	
	Cylindrical or Slotted type		
21	Peripheral strength member description		
22	Central Fibre optic unit	Y/N	
23	Loose tube dia & material		
24	Loose tube lay direction		
25	No of fibres per tube		
26	Total no. of tubes and number of empty tubes		
27	Identification / numbering of individual tubes		
28	Filling compound within tube		
29	Filling compound in cable core interstices		
30	Rip cord (s) provided ?	Y/N	
31	Cable design life	Years	
32	Describe cable termite proofing measures		
33	Describe cable anti-rodent measures		
<b>Cable Drums</b>			
34	Cable drum construction(annex drawing)		
35	Size of drum		
36	Weight of empty drum		

*Table 01 : Guaranteed Technical Particulars for Approach Cable*

**1.3.1 Data Requirements Sheet for PLB Pipe**

Please provide detailed data sheets/manuals etc. as supporting documents

<b>Manufacturer</b>			
<b>Model</b>			
<b>Sl. No.</b>	<b>Parameter</b>	<b>Unit</b>	<b>Guaranteed Value</b>
PLB HDPE Pipe parameters			
1	Manufacturer		
2	Pipe diameter(outside) nominal tolerance	mm	
3	Wall thickness nominal tolerance	mm	
4	Standard Length	mm	
	Nominal	mm	
	Tolerance		
5	Weight	Kg/km	
6	Two concentric layers type/ Homogeneous type Construction		
7	Thickness of permanent lubricant	mm	
8	Construction material of outer layer		
9	Construction material of inner layer		
10	Pipe colour		
11	Inner layer colour		
12	Base HDPE Resin	Kg/m <sup>3</sup>	
	(a)Density at 270 C	g/10	
	(b)Melt flow rate at 1900 C & 5 kg load	minutes	
13	Service life span	year	
14	Maximum outside diameter of FO cable that can be installed by blowing technique	mm	
15	Suitable for underground cable installation by-	Y/N	
	(a) Blowing :		
	(b) Pulling :		
16	Suitable for laying in trenches by-	Y/N	

<b>Manufacturer</b>			
<b>Model</b>			
<b>Sl. No.</b>	<b>Parameter</b>	<b>Unit</b>	<b>Guaranteed Value</b>
	(a)Directly burying		
	(b)Through G.I./RCC hume pipe		
17	Suitable for laying through trench less horizontal direction drilling	Y/N	
18	Tensile strength	N/mm <sup>2</sup>	
19	Elongation at break	%	
20	Internal coefficient of friction		
21	Bend radius	mm	
22	Draw rope details	mm	
	(a) Construction	kg	
	(b) Diameter		
	(c) Material		
	(d) Breaking Load Strength		
23	Describe anti rodent measures of PLB HDPE pipes		
<b>Pipe accessories</b>			
24	Coupler type		
25	Coupler material		
26	Coupler strength		
27	End cap material		

Table 102: Guaranteed Technical Particulars for PLB Pipe

## 1.4. Operational Facilities Requirements Specifications

The selected bidder should adhere to the specifications given below for Non-IT components. It is essential that Fire Proof material be used as far as possible and certification from Fire Department be taken for Network Operations Centre before Go-Live.

### 1.4.1 NOC Layout & Cabling

The Approximate floor layout dimensions are provided below for the NOC setup.

S No	Location	Approx. Dimension in Sq. ft.
1	Server Room	600
2	BMS Room- 3 Seat Arrangement	150
3	PAC/ Utility Room	150
4	Electrical/ UPS Room	450
5	Staging Area	100
6	ISP Room	200
7	Storage room	100
8	Meeting Room	150
9	NOC room – with 10 Seater arrangement	250
10	Helpdesk- with 5 Seat arrangement	150
11	Toilet	60
12	Lunch & Pantry Area	120
13	Wash Area	40
14	Step Passage & Reception	480
15	Manager Room	100
	<b>Total</b>	<b>3100</b>

### 1.4.2 Humidity, Ventilation and Air Conditioning systems

The NOC should be precision environment controlled. The temperature inside Server Farm area should be maintained at 20 degree centigrade with a precision of  $\pm 1$  degrees. It is suggested to provide air supply typically through false flooring.

a. Air conditioning

- 9 Since Server Farm area is a critical area, a separate air conditioning system (precision air conditioning) should be exclusively installed to maintain the required temperature. Other Rooms like NOC, Helpdesk & BMS rooms can have a common air conditioning system for comfort. The general requirements for the two zones are as specified below:
- 9 Server Farm Area – Should be provided with precision air conditioning on a 24 x 7 x 365 days operating basis at least meeting with Tier - III having n+1 redundancy architecture requirements and having enough provision to scale it to next level as may be required in a later stage. The units should be able to switch the air conditioner on and off automatically and alternately for effective usage. The units should be down-flow fashion, air-cooled conditioning system. Precision Air Conditioning systems specifically designed for stringent environmental Control with automatic monitoring and control of cooling, heating, humidification, dehumidification and air filtration function should be installed. The heat load calculation of the system proposed should be provided by the bidder as per the details of the racks given at the power requirement.



The units should be capable to run in synchronized mode to control the temperature and humidity of the area.

- 9 Other Area: Should be provided with split-type comfort air-cooled system (at least meeting with Tier - III architecture requirements). Help Desk & NOC area should be provided with a separate air conditioning system, so that the air conditioning units can be switched off whenever required.
- b. Natural Convection: As the conditioned air is supplied through the grills with volume control dampers on the floor, the cold air-cools the component in a much faster and efficient manner as it does moves up, after extracting heat from the component. This follows the natural convection path of the air. The warm air should be sucked at the top by machine, air-conditioned and then supplied back to the room.
- c. Air Distribution: The air is to be distributed evenly by providing grills with Volume Control Dampers (VCD) in the floor tiles.
- d. Flexibility: The system should give the flexibility of discharging air at wherever point required even if the furniture is relocated. Changing the grill/tiles carrying grills, at suitable location does this.
- e. False Ceiling: The top false ceiling would have 1' 6'' feet of space from the actual Room ceiling. This false ceiling will house AC ducting (if required) and cables of Electrical lighting, Fire-fighting, Rodent Control and CCTV.
- f. The electrical cabling Work shall include the following:
  - 9 Main Electrical Panel
  - 9 Power Cabling
  - 9 UPS Distribution Board
  - 9 UPS Point Wiring
  - 9 Power Cabling for Utility component and Utility Points etc
  - 9 Online UPS
  - 9 Separate Earth Pits for the component
- g. The distribution of power from the UPS room to the following shall be considered:
  - 9 All proposed component for the production environment
  - 9 UPS with static bypass arrangement
  - 9 Sub distribution panels for UPS
  - 9 Final Distribution shall be through Power Distributions Units (PDU)/MCB Distribution Boxes.
- h. The bidder is required to maintain two electrical distribution paths (one normal & one alternate) for the cabling inside the server farm area.
- i. Bunching of Wires – Wires carrying current shall be so bunched in the conduit that the outgoing and return wires are drawn into the same conduit. Wires originating from two different phases shall not be run in the same conduit.
- j. Drawing of Conductors – The drawing Aluminum / Copper conductor wires shall be executed with due regards to the following precautions while drawing insulated wires in to conduits. Care shall be taken to avoid scratches and kinks, which cause breakages.
- k. Joints – All joints shall be made at main switches, distribution boards, socket outlets, lighting outlets and switch boxes only. No joints shall be made inside conduits and junction boxes. Conductors shall be continuous from outlet to outlet.
- l. Mains & Sub-Mains – Mains & sub-mains wires where called for shall be of the rated capacity. Every main and sub-main shall be drawn into an independent adequate size conduit. Adequate size draw boxes shall be provided at convenient locations to facilitate easy drawing of the mains and sub -mains. An independent earth wire of proper rating shall be provided. The earth wires shall run along the entire length of the mains and sub-mains.
- m. Load Balancing – Balancing of circuits in three-phase installation shall be planned before the commencement of wiring.
- n. Color Code of the Conductors – Color code shall be maintained for the entire wiring installation, Red, Yellow, Blue for three phases and “OFF” circuit black for neutral and green for earth (or bare earth).
- o. Fixing of the Conduits – Conduits junction boxes shall be kept in position and proper holdfasts shall be provided. Conduits shall be so arranged as to facilitate easy drawing of the wires through them. Adequate junction boxes of standard shape & size shall be provided. All conduits shall be installed so as to avoid

stream and hot water pipes. After conduits, junction boxes, outlet boxes & switch boxes are installed in position their outlets shall be properly plugged so that water, mortar, insects or any other foreign matter does not enter into conduit system. Conduits shall be laid in a neat and organized manner as directed and approved by the Information Technology Department Personnel or person on their behalf. Conductors shall be planned so as not to conflict with any other service pipe lines / ducts.

- p. Protection – To minimize condensation or sweating inside the conductors all outlets of conduit system shall be adequately ventilated and approved by the proper competent authority. All screwed and socketed connections shall be adequately made fully water tight by use of proper jointing materials.
- q. Switch-Outlet Boxes and Junction Boxes – All boxes shall conform to all prevailing Standards. The cover plates shall be of best quality Hylam sheets or ISI grade Urea Formaldehyde Thermosetting insulating material or equivalent, which should be mechanically strong and fire retardant. Proper support shall be provided to the outer boxes to fix the cover plates of switches as required. Separate screwed earth terminals shall be provided inside the box for earthing purpose.
- r. Inspection Boxes – Rust proof inspection boxes of required size having smooth external and internal Finish shall be provided to permit periodical inspection and to facilitate removal and replacement of wires when required

### 1.4.3.Civil & Architectural work

The scope for civil work in this RFP is to furnish the NOC in all aspects. The furnishing includes but not limited to the following:

- § Glazing
- § False Flooring
- § False Ceiling
- § Storage
- § Furniture & fixture
- § Partitioning
- § Doors and Locking
- § Painting
- § Fire proofing all surfaces
- § Insulating

### 1.4.4.PVC Conduit

- § The conduits for all systems shall be high impact rigid PVC heavy-duty type and shall comply with I.E.E regulations for nonmetallic conduit 1.6 mm thick as per IS 9537/1983.
- § No conduit less than 20mm external diameter shall be used. Conduit runs shall be so arranged that the cables connected to separate main circuits shall be enclosed in separate conduits, and that all lead and return wire of each circuit shall be run to the same circuit.
- § All conduits shall be smooth in bore, true in size and all ends where conduits are cut shall be carefully made true and all sharp edges trimmed. All joints between lengths of conduit or between conduit and fittings boxes shall be pushed firmly together and glued properly.
- § Cables shall not be drawn into conduits until the conduit system is erected, firmly fixed and cleaned out. Not more than two right angle bends or the equivalent shall be permitted between draw and junction boxes. Bending radius shall comply with I.E.E regulations for PVC pipes.
- § Conduit concealed in the ceiling slab shall run parallel to walls and beams and conduit concealed in the walls shall run vertical or horizontal.

### 1.4.5.Wiring

- § PVC insulated copper conductor cable shall be used for sub circuit runs from the distribution boards to the points and shall be pulled into conduits. They shall be stranded copper conductors with thermoplastic insulation. Color code for wiring shall be followed.

## Volume- II

---

- § Looping system of wiring shall be used, wires shall not be jointed. No reduction of strands is permitted at terminations.
- § Wherever wiring is run through trunking or raceways, the wires emerging from individual distributions shall be bunched together with cable straps at required regular intervals. Identification ferrules indicating circuit and D.B. number shall be used for sub main, sub circuit wiring the ferrules shall be provided at both end of each sub main and sub-circuit.
- § Where, single phase circuits are supplied from a three phase and a neutral distribution board, no conduit shall contain wiring fed from more than one phase in any one room in the premises, where all or part of the electrical load consists of lights, fans and/or other single phase current consuming devices, all shall be connected to the same phase of the supply.
- § Circuits fed from distinct sources of supply or from different distribution boards or M.C.B.s shall not be bunched in one conduit. In large areas and other situations where the load is divided between two or three phases, no two single-phase switches connected to different phase shall be mounted within two meters of each other.
- § All splicing shall be done by means of terminal blocks or connectors and no twisting connection between conductors shall be allowed.
- § Metal clad sockets shall be of die cast non-corroding zinc alloy and deeply recessed contact tubes. Visible scraping type earth terminal shall be provided. Socket shall have push on protective cap.
- § All power sockets shall be piano type with associated switch of same capacity. Switch and socket shall be enclosed in a M. S. sheet steel enclosure with the operating knob projecting. Entire assembly shall be suitable for wall mounting with Bakelite be connected on the live wire and neutrals of each circuit shall be continuous everywhere having no fuse or switch installed in the line excepting at the main panels and boards. Each power plug shall be connected to each separate and individual circuit unless specified otherwise. The power wiring shall be kept separate and distinct from lighting and fan wiring. Switch and socket for light and power shall be separate units and not combined one.

### 1.4.6.Cable Work

- § Cable ducts should be of such dimension that the cables laid in it do not touch one another. If found necessary the cable shall be fixed with clamps on the walls of the duct. Cables shall be laid on the walls/on the trays as required using suitable clamping/ fixing arrangement as required. Cables shall be neatly arranged on the trays in such manner that a crisis crossing is avoided and final take off to switch gear is easily facilitated.
- § Each section of the rising mains shall be provided with suitable wall straps so that same can be mounted on the wall.
- § Whenever the rising mains pass through the floor they shall be provided with a built-in fire proof barrier so that this barrier restricts the spread of fire through the rising mains from one section to the other adjacent section.
- § Neoprene rubber gaskets shall be provided between the covers and channel to satisfy the operating conditions imposed by temperature weathering, durability etc.
- § Necessary earthing arrangement shall be made alongside the rising mains enclosure by means of a GI strip of adequate size bolted to each section and shall be earthed at both ends. The rising mains enclosure shall be bolted type.
- § The space between data and power cabling should be as per standards and there should not be any crisscross wiring of the two, in order to avoid any interference, or corruption of data.

### 1.4.7 Electrical Panels

- § The Panels shall be of compartmentalized design so that circuit arc / flash products do not create secondary faults and be fabricated out of high quality CRCA sheet, suitable for indoor installation having dead front operated and floor mounting type.
- § All CRCA sheet steel used in the construction of Panels shall be 2 mm. thick and shall be folded and braced as necessary to provide a rigid support for all components. Joints of any kind in sheet steel shall be seam welded, all welding slag grounded off and welding pits wiped smooth with plumber metal.
- § The Panels shall be totally enclosed, completely dust and vermin proof and degree of protection being not less than IP: 54 to IS: 2147. Gaskets between all adjacent units and beneath all covers shall be provided to

render the joints dust proof. All doors and covers shall be fully gasketed with foam rubber and /or rubber strips and shall be lockable.

- § All panels and covers shall be properly fitted and secured with the frame and holds in the panel correctly positioned. Fixing screws shall enter into holes, taped into an adequate thickness of metal or provided with bolts and nuts. Self-threading screws shall not be used in the construction of Panels.
- § Panels shall be preferably arranged in multi-tier formation. The size of the Panels shall be designed in such a way that the internal space is sufficient for hot air movement. If necessary, openings shall be provided for natural ventilation, but the said openings shall be screened with fine weld mesh. The entire electrical component shall be derated for 50 degree celsius.
- § The Panels shall be provided with removable sheet steel plates at top and bottom to drill holes for cable / conduit entry at site.
- § The Panels shall be designed to facilitate easy inspection, maintenance and repair.
- § The Panels shall be sufficiently rigid to support the equipment without distortion under normal and under short circuit condition. They shall be suitably braced for short circuit duty

### 1.4.8.Circuit Compartments

- § Each MCCB shall be housed in separate compartments and shall be enclosed on all sides. Sheet steel hinged lockable door shall be duty interlocked with the unit in `ON' and `OFF' position.
- § All instruments and indicating lamp shall be mounted on the compartment door. Sheet steel barriers shall be provided between the tiers in a vertical section.

### 1.4.9 Instrument Compartments

- § Separate adequate compartment shall be provided for accommodating instruments, indicating lamps, control contactors/ relays and control fuses etc.
- § These components shall be accessible for testing and maintenance without any danger of accidental contact with live parts, bus bar and connections

### 1.4.1 Busbars

- § The busbar shall be air insulated and made of high quality, high conductivity, high strength Aluminum.
- § The busbar shall be of 3 phases and neutral system with separate neutral and earth bar. The size of neutral busbar in all main panels or lighting panels and feeders for panel shall be equal to phase busbar.
- § The busbar and interconnection between busbars and various components shall be of high conductivity Aluminum.
- § The busbar shall be of rectangular cross-section designed to withstand full load current for phase busbars and half rated current for neutral busbars in case of MCC panels only and shall be extensible on either side.
- § The busbar size shall be as per the rating of the panel. The busbar shall have uniform cross-section throughout the length.
- § The busbars and interconnections shall be insulated with epoxy-coated busbar. The busbar shall be supported on bus insulators of non-flammable type with high creep age and high anti tracking property and non-hydroscopic SMC / DMC insulated supports at sufficiently close intervals to prevent busbars sag and shall effectively withstand electromagnetic stresses in the event of short circuit.
- § The busbar shall be housed in a separate compartment.
- § All busbar connections shall be done by drilling holes in busbars and connecting by chromium plated or tinned plated brass bolts and nuts.
- § Additional cross-section of busbar shall be provided in all Panels to cover up the holes drilled in the busbar. Spring and flat washers shall be used for tightening the bolts.
- § All connections between busbars and circuit breakers / switches and cable terminals shall be through aluminum strips of proper size to carry full rated current. These strips shall be insulated with insulating taps.
- § Panel to panel entry of bus bar shall be effectively sealed by electrical and thermal insulation barriers so that products of flashover do not travel from one panel to another panel creating multiple faults.
- § Busbar calculated on 50 deg. C. ambient temperature and 85 deg. C. for continuous and short time rating. Busbar surrounded air temperature shall be considered 70 deg. C. for bus bar calculation
- § All joint shall have non-flammable insulation shrouds for secondary insulation purpose

### **1.4.1 Electrical Power and Control Wiring Connection**

- § Terminal for both incoming and outgoing cable connections shall be suitable for 1100 V grade, aluminum / copper conductor XLPE insulated and PVC sheathed, armored cable and shall be suitable for connections of solder less sockets for the cable size as per the feeder capacity.
- § Power connections for incoming feeders of the main Panels shall be suitable for 1100 V grade Aluminum conductor (XLPE) cables.
- § Both control and power wiring shall be brought out in cable alley for ease of external connections, operation and maintenance.
- § Both control and power terminals shall be properly shrouded.
- § 10% spare terminals shall be provided on each terminal block. Sufficient terminals shall be provided on each terminal block, so that not more than one outgoing wire is connected to per terminal.
- § Terminal strips for power and control shall preferably be separated from each other by suitable barriers of enclosures.
- § Wiring inside the modules for power, control, protection and instruments etc. shall be done with use of 660 / 1100 V grade, FRLS insulated copper conductor cables conforming to IS.
- § Other control wiring shall be done with 1.5 sq.mm. Copper conductor wires.
- § Wires for connections to the door shall be flexible. All conductors shall be crimped with solder less sockets at the ends before connections are made to the terminals.
- § Control power supply to modules through the control transformer Control power wiring shall have control fuses, (HRC fuse type) for circuit protection. All indicating lamps shall be protected by HRC fuses.
- § Particular care shall be taken to ensure that the layout of wiring is neat and orderly. Identification ferrules shall be filled to all the wire termination for ease of identification and to facilitate checking and testing

### **1.4.12 Terminals**

- § The outgoing terminals and neutral link shall be brought out to a cable alley suitably located and accessible from the panel front.
- § No direct connection of incoming or outgoing cables to internal components of the distribution board is permitted; only one conductor may be connected in one terminal

### **1.4.13 Cable Compartments**

- § Cable compartments of minimum 300 mm size shall be provided in the Panels for easy termination of all incoming and outgoing cables entering from bottom or top.
- § Adequate supports shall be provided in the cable compartments to support cables.
- § All outgoing and incoming feeder terminals shall be brought out to terminals blocks in the cable compartment.

### **1.4.14 Labels**

- § Engraved PVC labels shall be provided on all incoming and outgoing feeders.
- § Single line circuit diagram showing the arrangements of circuit inside the distribution board shall be pasted on inside of the panel door and covered with transparent laminated plastic sheet.

### **1.4.15 Name Plates**

- § A nameplate with the Panels designation in bold letters shall be fixed at top of the central panel.
- § A separate nameplate giving feeder details shall be provided for each feeder module door.
- § Inside the feeder compartments, the electrical components, equipments, accessories like switchgear, control gear, lamps, relays etc. shall suitably be identified by providing stickers.
- § Engraved nameplates shall preferably be of 3 ply, (Red-White-Red or Black-White-Black) lamicold sheet. However, black engraved perplex sheet name plates shall also be acceptable. Engraving shall be done with square groove cutters.
- § Nameplate shall be fastened by counter sund screws and not by adhesives

### 1.4.1 Danger Notice Plates

- § The danger notice plate shall be affixed in a permanent manner on operating side of the Panels.
- § The danger notice plate shall indicate danger notice both in Malayalam and English and with a sign of skull and bones.
- § The danger notice plates, in general, meet the requirements of local inspecting authorities.
- § Overall dimensions of the danger notice plate shall be 200 mm. wide x 150 mm. high.
- § The danger notice plate shall be made from minimum 1.6 mm. thick mild steel sheet and after due pre-treatment to the plate, the same shall be painted white with vitreous enamel paint on both front and rear surface of the plate.
- § The letters, the figures, the conventional skull and bones etc. shall be positioned on plate as per recommendation of IS: 2551-1982.
- § The said letters, the figures and the sign of skull and bones shall be painted in signal red colour as per IS : 5-1978.
- § The danger plate shall have rounded corners. Location of fixing holes for the plate shall be decided to suit design of the Panels.
- § The danger notice plate, if possible, it should be of ISI certification mark

### 1.4.1 Molded Case Circuit Breakers

- § The molded case circuit breaker (MCCB) shall be air break type and having quick make - quick break with trip free operating mechanism.
- § Housing of the MCCB shall be of heat resistant and flame retardant insulating material.
- § Operating handle of the MCCB shall be in front and clearly indicate ON/OFF/TRIP positions.
- § The electrical contact of the circuit breaker shall be of high conducting non-deteriorating silver alloy contacts.
- § The MCCB shall be provided microprocessor based overload and short circuit protection device.
- § All the releases shall operate on common trip busbar so that in case of operation of any one of the releases in any of the three phases, it will cut off all the three phases and thereby single phasing of the system is avoided.
- § The MCCB shall provide two sets of extra auxiliary contacts with connections for additional controls at future date.

### 1.4.1 Contactors

- § The contactors shall meet with the requirements of IS : 2959 and BS : 7755.
- § The contactors shall have minimum making and breaking capacity in accordance with utilization category AC3 and shall be suitable for minimum Class II intermittent duty.
- § If the contactor forms part of a distribution board then a separate enclosure is not required, but the installation of the contactor shall be such that it is not possible to make an accidental contact with live parts

### 1.4.1 Indicating Lamps

- § Indicating lamps assembly shall be screw type with built in resistor having non-fading colour lens. LED type lamps are required.
- § Wiring for Remote ON, OFF, TRIP indicating lamp is required.
- § Colour shade for the indicating lamps shall be as below:
  - 9 ON indicating lamp : Red
  - 9 OFF indicating lamp : Green
  - 9 TRIP indicating lamp : Amber
  - 9 PHASE indicating lamp : Red, Yellow, Blue
  - 9 TRIP circuit healthy lamp : Milky

### 1.4.2 Cable Trays

The cable trays shall be of ladder type / perforated steel section slotted angles. The trays shall be complete with plates, Ts, elbows, risers, and all necessary hardware. The trays shall be galvanized as per IS 2629. The cable trays shall have suitable strength and rigidity to provide adequate support for all cables. It shall not present sharp edges, burrs or projections, injurious to the insulation of the wiring and cables. The trays shall be adequately protected against

corrosion and shall be made of corrosion resistant material. It shall have side rails or equivalent structural members. There shall be a continuous earth strip running on either side of the tray for earthing. The distance between power cable tray/ conduit and data cable tray/ conduit should be between 1 to 1.5 feet.

### 1.4.2 Earthing

- § All electrical components are to be earthen by connecting two earth tapes from the frame of the component ring and will be connected via several earth electrodes. The cable arm will be earthen through the cable glands. Earthing shall be in conformity with provision of rules 32, 61, 62, 67 & 68 of Indian Electricity rules 1956 and as per IS-3043. The entire applicable IT infrastructure in the Control Rooms shall be earthed.
- § Earthing should be done for the entire power system and provisioning should be there to earth UPS systems, Power distribution units, and AC units etc. so as to avoid a ground differential. State shall provide the necessary space required to prepare the earthing pits.
- § All metallic objects on the premises that are likely to be energized by electric currents should be effectively grounded.
- § The connection to the earth or the electrode system should have sufficient low resistance in the range of 0 to 25 ohm to ensure prompt operation of respective protective devices in event of a ground fault, to provide the required safety from an electric shock to personnel & protect the equipment from voltage gradients which are likely to damage the equipment.
- § Recommended levels for equipment grounding conductors should have very low impedance level less than 0.25 ohm.
- § In case of a UPS and Transformer equipment, the Earth resistance shall be automatically measured on an online basis at a pre-configured interval and corrective action should be initiated based on the observation. The automatic Earthing measurements should be available on the UPS panel itself
- § There should be enough space between data and power cabling and there should not be any cross wiring of the two, in order to avoid any interference, or corruption of data.
- § The earth connections shall be properly made.
- § A complete copper mesh earthing grid needs to be installed for the server farm area, every rack need to be connected to this earthing grid. A separate earthing pit needs to be in place for this copper mesh.
- § Provide separate earthing pits for servers, UPS & generators as per the standards.



**SECTION V**  
***Project Management, Training, Inspection & Test  
Documentation***



# 1. Project Management, Schedule and Implementation Plan

This section describes the project management, schedule, quality assurance, and implementation plan requirements for both the packages.

## 1.1. Project Governance Structure

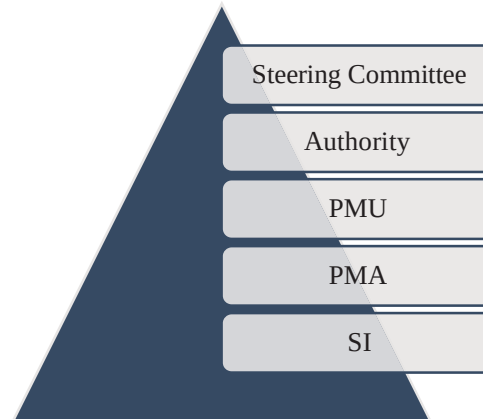


Figure 3: Project Governance Structure

1. The Steering Committee will consist of senior stakeholders from the GoK, Power Dept., Electronics & IT Dept., KSEBL, Authority, its nominated agencies. It will also include key persons from other relevant stakeholders and other officials / representatives by invitation from the Authority.
2. The SI shall participate in the Steering Committee meetings and update Steering Committee on project progress, risk parameters (if any), resource deployment and plan, immediate tasks, and any obstacles in project. The Steering committee meeting will be a forum for seeking and getting approval for project decisions on major changes etc.
3. All relevant records of proceedings of Steering Committee should be maintained, updated, tracked and shared with the SI.
4. During the implementation phase of the project, it is expected that there will be at least monthly Steering Committee meetings. During the O&M phase, the meetings will be held at least once bi-monthly.
5. Other than the planned meetings, in exceptional cases, Authority may call for a Steering Committee meeting with prior notice to the SI.

## 1.2. Stakeholders of the Project & their Responsibilities

The roles of the stakeholders shall change over a period of time as the Project will evolve from design to implementation and enter the operations phase. Stakeholders and their responsibilities for the Package A is given below:

### 1.2.1 Systems Integrator

- ξ Shall carry out the work as specified in the Scope of Work in this tender within the timelines which includes route survey, procurement of material, installation, testing, commissioning and operations & maintenance and any other implementation work

## Volume- II

---

- § Preparation, submission of design & engineering documents/data/reports/progress reports/monthly plans/installation guidelines as required in the required formats and uploading of same in Project Monitoring Tool/ GIS platform etc.
- § Warehouse management (Store/inventory)
- § Engineering and technical assistance during the contract and guarantee period.
- § Adherence to standards, guidelines and procedures laid down by Authority and any statutory compliances/laws that are applicable like labour laws etc.
- § Coordination with the various agencies like Authority, KSEBL, PMA, PMU, government & educational institutions

### 1.2.2 Project Monitoring Agency (PMA)

- § PMA shall verify and certify the quality as well as quantity of the work done for material, PON OTDR Testing, End to End Testing, checks and review of trenching, installation of OFC /Duct, refilling of trench, splicing etc. for all 100% sites
- § Verification of site survey reports and ABDs
- § Quality review of the work done by SI on day to day basis for all 100% sites
- § Complete passive infrastructure shall be validated as per the engineering instructions provided in this RfP
- § Complete acceptance testing of the active and passive equipment shall be done as per the technical specifications mentioned in the RfP
- § Acceptance Testing of the Network Operation Center, PoPs and end locations
- § Preparation, submission of data/reports/certificates as required in the required formats to PMU and uploading of same in Project Monitoring Tool
- § Adherence to standards, guidelines and procedures laid down by Authority
- § Ensuring availability of verification and validation personnel in line with the implementation schedule and site level coordination with SIs for carrying out the tasks.
- § Audit and inspection of material at warehouse maintained by SI

### 1.2.3 Project Management Unit (PMU)

- § Verification of SI's final deliverables including design document, architecture and BoQ made on the basis of verified survey reports, Test reports
- § For each payment milestone, SI will submit all the documents/forms and certificates issued by PMA to the PMU. Payment for the respective milestones will be released after verification of documents by PMU.
- § Creation of project manual comprising:
  - o Project governance structure
  - o Monitoring and evaluation mechanism
  - o Project level procedures including
  - o Implementation guidelines, standards and checklists
  - o Testing and acceptance process
  - o Issues reporting and management process
  - o Other project management and coordination procedures
- § Centralized planning and information sharing between relevant stakeholders
- § Defining and monitoring of implementation and maintenance SLAs

### 1.2.4 KSEBL

- § Appoint nodal officers for coordination with SI/PMA appointed for this project
- § Provide specification of the OFC that has been used in their existing network
- § Shall provide assistance for restoration of the fibre cuts
- § Shall provide required space at substations for installing equipment in pre-fabricated structures for setting up PoPs within the overall safety parameters of KSEBL
- § Shall provide required power supply at substation PoPs
- § Shall grant permission to the personnel authorized by Authority for accessing KFON infrastructure located at substations following the permit system of KSEBL

## Volume- II

---

- § Shall provide site level coordination with personnel authorized by the Authority
- § Shall assist in validating the fibre route network prepared by SI and supply up-to-date KSEBL network data required for expansion/upgradation of KFON
- § Shall guide and provide supervisory services for all obligatory compliances/ Rules/Regulations/SOPs/Safety measures as required by KSERC or KSEBL for accessing power infrastructure
- § SLA compliance during maintenance phase for the network owned by KSEBL, as per the terms agreed with Authority
- § Provide support for fault diagnosis and repair during maintenance phase for the network components owned by KSEBL
- § Participation in factory and site acceptance tests.
- § Providing support and access to facilities at the sites
- § Provide to the extent possible drawings for existing sites and facilities for which equipment installations are planned.

### 1.2.5 Authority

- § Overall project management
- § Decision making/Issue resolution
- § Appointment of agencies like SI/ PMU/PMA for project implementation, its monitoring and management
- § Apply for right of way, access to premises and other relevant permissions for carrying out implementation work like laying of OFC, trenching, terminating network at office locations etc.
- § Sign-offs on test reports/acceptance/design documents, etc. based on the recommendations/certificates issued by PMU/PMA
- § Processing of vendor invoices and recommendation/release of payments.
- § Participation in and approval of factory and site acceptance tests.
- § Release of payments

### 1.3. Project Office & Team

SI shall set up a Project Office during the start of the project in Thiruvananthapuram. The project shall be staffed from the list of project management and engineering personnel presented in the proposal.

SI will also deploy site engineers and site managers to continuously monitor the work being executed simultaneously in different areas of the state. The appropriate number of Site Engineers and Supervisors to be deployed by SI as per the project requirements. They will perform following activities but not limited to:

- § Supervise ongoing work to ensure that all specifications, standards and quality norms are followed.
- § Preparation of ITP (Inspection and Test Plans) reports, splicing reports, LSPM and bi-directional OTDR reports.
- § Provide progress reports to Site Manager along with critical field issues and support required.
- § Coordinate timely active and passive material delivery at site.
- § Coordinate availability of all resources splicing machine, testing tools, labour etc. as per requirement.
- § Installation and commissioning of all active elements with required specifications.
- § Supervise establishment of all major PoP inside existing facilities and any additional set up required in the NOC etc.

## **1.4. Reporting & Meetings**

### **1.4.1 Progress Reporting**

With the intent to assure quality management and project progress as per the implementation schedule, progress reports submitted for each reporting period and Progress Review Meetings shall focus on the following:

#### **1.4.1. Monthly Progress Reports**

The SI shall also circulate written monthly progress reports to Authority, PMU and other stakeholders by ~~of~~ every month. The report shall include activities performed by the SI in the reporting period, Progress against the Project Management Plan, deviations against plan and its impact on the project timelines, status of all risks and issues, training schedule, activities for the next period, intervention required from the Authority, log of all/pending invoices submitted, change requests, list of all deliverables submitted and its acceptance status, exceptions along with recommended resolution etc. It shall include but not limited to:-

- (a) Updated project schedule highlighting any deviations from the previous issue of the project schedule
- (b) Explanation and anticipated effect of each schedule deviation and its implication to the Authority
- (c) Schedule recovery plan for any deviation incurring a delay in delivery date. (All delays shall be factored into the project schedule as soon as they are known to the SI.)
- (d) A summary of activities performed by the SI and the Authority during the previous reporting period
- (e) An updated list of all correspondence transmitted and received by the SI
- (f) Updated documentation schedule
- (g) Updated training schedule
- (h) Updated list of SI and the Authority action items with status, description of required information, and required resolution dates
- (i) Summary of pending and upcoming SI and the Authority activities during the next two reporting periods along with required completion dates
- (j) Status of unresolved contract questions and change requests
- (k) Summary of variances
- (l) Log of invoice status
- (m) Description of current and anticipated project problems and steps to be taken to resolve each problem.

#### **1.4.1. Bi-Monthly Progress Review Meetings**

Progress Review Meetings shall be scheduled by the project manager and attended by the SI and the Authority to review progress of the project. Progress meetings shall be used to review the progress reports for the previous reporting periods, written correspondence exchanged since the last meeting, and open action items.

Progress Review Meetings will be held formally on a monthly basis during the implementation period and once in two months during the O&M period with the Committees constituted by the Authority covering, at a minimum, the agenda items given below. SI shall circulate the Minutes of the meeting within two days.

- ξ Project Progress
- ξ Delays, if any – Reasons thereof and ways to make-up lost time
- ξ Issues and concerns
- ξ Performance and SLA compliance issues;
- ξ Unresolved and escalated issues;
- ξ Project risks and their proposed mitigation plan

## Volume- II

---

- ξ Discussion on submitted deliverable
- ξ Timelines and anticipated delay in deliverable if any
- ξ Any other issues that either party wishes to add to the agenda.
- ξ During the development and implementation phase, there may be a need for more frequent meetings and the agenda would also include:
  - ξ Target dates for connectivity to prioritized locations specified by the Authority.
  - ξ Scope / design changes in fibre routes due to any field constraint / feasibility issue.
  - ξ IT infrastructure procurement and deployment status
  - ξ Status of setting up/procuring of the Helpdesk
  - ξ Any other issues that either party wishes to add to the agenda

The SI shall also attend technical meetings as required to discuss technical aspects of the project and to review the Authority comments on approval documents. When appropriate, these splinter meetings shall be conducted as extensions to the progress meetings.

Other than the planned meetings, in exceptional cases, project status meeting may be called with prior notice to the SI. Authority reserves the right to ask the SI for the project review reports other than the standard monthly review reports.

Record the minutes of each meeting shall be prepared and provided as hard copies to all attendees on the same day whenever possible; but not later than within two working days after the meeting. The below provides a suggested agenda for Progress Review Meetings.

SI. No.	Title	Description
1	Meeting Minutes:	Review minutes from previous meeting, with comments
2	Open Action Items:	Review all outstanding action items
3	Progress Review:	Review with participating Project Managers and SI, most recent project schedule. Update schedule and develop Action Items.
4	Technical Discussion:	Discuss Technical Issues.
5	Action Items:	Assign responsibilities for new action items.
6	Administrative Matters:	Discuss administrative matters
7	Next Meeting:	Schedule time and place for next meeting and agree on agenda
8	Adjourn:	Adjourn meeting.

*Table 103: Suggested Progress Review Meeting Agenda*

### 1.4.2.Transmittals

Every document, letter, progress report, change order, and any other written or electronic media transmissions exchanged between SIs and the Authority shall be assigned a unique transmittal number. Discussions and phone calls where project related information is exchanged shall be documented in a transmittal. The SI shall maintain a

correspondence index and assign transmittal numbers consecutively for all SI documents. The Authority will maintain a similar correspondence numbering scheme identifying documents and correspondence that the Authority initiates.

### **1.4.3. Quality Assurance**

#### **1.4.3.1 General**

The SI shall adhere to a Quality Assurance (QA) program for the preparation of all Contract deliverables, including documentation and hardware. The program shall provide for early detection of actual or potential deficiencies, timely and effective corrective action, and a method of traceability of all such deficiencies.

The relevant ISO 9000 standards to be provided are the following:

- a ISO 9001: model for quality assurance in design, development, production, installation and servicing
- b ISO 9002: model for quality assurance in production and installation
- c ISO 9003: model for quality assurance in final inspection and testing

The Quality Assurance procedures, documentation standards, and software development procedures which were included in the Bidder's proposal will be incorporated into the Contract.

#### **1.4.3.2 Quality Assurance System and Requirements**

The ISO 9001 Certificate and the assessment and visit reports shall be available to the Authority throughout the duration of the contract.

The Quality Assurance program shall be outlined by the SI and shall be finally accepted by the Authority after discussions before the award of contract. A Quality Assurance program of the SI shall generally cover but not limited to the following:

- a Organizational structure for the management and implementation of the proposed quality assurance program.
- b Documentation control system.
- c Qualification data for SI's key personnel
- d The procedure for purchases of materials, parts/components and selection of sub-material inspection, verification of material purchases etc.
- e System for shop manufacturing including process controls and fabrication and assembly controls.
- f Control of non-conforming items and system for corrective action. SI's services including vendor analysis, source inspection, incoming raw material inspection, verification of material purchases etc.
- g Control of calibration and testing of measuring and testing equipment.
- h Inspection and test procedure for manufacture.
- i System for indication and appraisal of inspection status.
- j System for quality audits
- k System for authorizing release of manufactured product to the Authority.
- l System for maintenance for records.
- m System for handling storage and delivery
- n A quality plan detailing out the specific quality control procedure adopted for controlling the quality characteristics of the product.

The Quality Assurance Plan shall be mutually discussed and approved by the Authority after incorporating necessary corrections by the SI as may be required.

This Quality Assurance plan shall then form part of the contractual documentation and shall not be changed without prior agreement with the Authority. The SI shall be required to submit all the Quality Assurance Documents as stipulated in the Quality Assurance Plan at the time of the Authority's inspection of equipment/material.

The Authority or its duly authorized representatives reserve the right to carry out Quality Audit and quality surveillance of the systems and procedures of the SI / his vendor's Quality Management and Control Activities.

### **1.4.4 Document Review and Approval Rights**

To ensure that the proposed systems conform to the specific provisions and general intent of the Specification, the SI shall submit documentation describing the systems to the Authority for review and approval.

The Authority will respond with written comments to the SI within fifteen (15) working days after receipt of the documents. Documents requiring correction must be resubmitted by the SI to the Authority within 15 working days. The Authority will respond to resubmitted documents within fifteen (15) working days after receipt of the document. No implementation schedule relief is to be implied for documents requiring correction and resubmission to the Authority.

The Authority shall have the right to require the SI to make any necessary documentation changes at no additional cost to the Authority to achieve conformance with the Specification.

Any purchasing, manufacturing, or programming implementation initiated prior to written approval of the Authority for the relevant documents or drawings shall be performed at the SI's own risk. Review and approval by the Authority shall not relieve the SI of its overall responsibilities to satisfy system functions and performance requirements in accordance with the Specification.

### **1.5. Project Schedule**

The project schedule shall consist of an implementation schedule, a documentation schedule, and a training schedule.

#### **1.5.1 Implementation Schedule**

The Bidder shall submit a preliminary project implementation schedule along with the Bid. The detailed project implementation schedule shall be submitted by the SI within two weeks of award of contract for Authority's approval. A soft copy of the implementation schedule files shall also be provided to the Authority. The overall project plan shall consist of a Milestone Plan and a Detailed Schedule Plan. The implementation schedule shall include the project milestones as specified in Volume I and the SI activities and the Authority's activities defined in this Section. The project schedule shall be an accurate representation of the progress and planned activities of the project.

The SI shall provide a critical path analysis report and a manpower resource analysis report. Other standard reports will be defined during the Work statement. The project schedule shall include all tasks to track overall direction and integration of the project from inception through completion. The Schedule Plan shall be developed utilizing the concept of Work Breakdown Structures. Each scheduled task shall have an estimated duration for completion and predefined relationships with other tasks. Relationships shall be used to enforce the logical progression of work in as much as certain tasks cannot start until others have been completed. No task shall be greater than 3 weeks in duration.

The actual progress made to date and the scheduled delivery date for the completed systems shall be closely monitored by both the SI and the Authority's PMU. The following information shall be reported to the Authority in a clear and concise manner using the tabular and graphic capabilities of the project management software:

- a) An overview and general assessment of all the Authority and SI activities and any progress or delays in these activities since the last reporting period
- b) Identification of tasks in the critical path together with an analysis indicating any required remedial action
- c) The amount of contingency time (float) remaining in the schedule
- d) Information on each task, including:
  - 1) Estimated start and finish dates
  - 2) Any change in the estimated dates since the last reporting period

- 3) Estimated total number of calendar-days to complete the task
  - 4) Percent of task completed
  - 5) An indication of whether the start date was manually entered or computed.
- e) Total project resources
  - f) The tasks to begin in the next two reporting periods
  - g) The tasks to be completed in the next two reporting periods
  - h) The tasks completed in the last two reporting periods

The content and format of the project schedule shall be subject to the Authority's approval. The SI shall update and submit the project schedule to the Authority at least one week prior to each progress meeting.

### **1.5.1.1SI Activities**

The implementation schedule shall be compiled by the SI summarizing all activities, and shall include but not be limited to the following:

- (a) Survey, Design & Engineering
- (b) Equipment purchases, development, and integration
- (c) Equipment production schedules
- (d) Documentation preparation and release
- (e) Documentation revision and release following the Authority's review
- (f) Type Tests and Factory testing
- (g) Shipment
- (h) Receipt, forwarding and storing
- (i) Installation
- (j) Site Acceptance testing
- (k) Acceptance Tests

Each scheduled task shall have an estimated duration for completion and predefined relationships with other tasks. Relationships shall be used to enforce the logical progression of work in as much as certain tasks cannot start until others have been completed.

### **1.5.1.2Authority's Activities**

The implementation schedule shall contain all the Authority's activities required in order for the SI to complete their systems and integration tasks, including the following:

- (a) Document reviews and approvals
- (b) Licensing and Regulatory Clearances, if any
- (c) Participation in all levels of testing and training
- (d) Any site preparations, if required.

### **1.5.1.3Documentation Schedule**

The documentation schedule shall include an entry for each document and drawing to be delivered throughout the project. Each documentation schedule entry shall include the document or drawing title, number, revision level, actual or future submittal date for the Authority review or approval, date of completion of review or approval by the Authority, and outcome of review or approval by the Authority. When the Authority requires correction to any document, the documentation schedule shall be updated with a new entry for the next revision of the document. The content and format of the documentation schedule shall be subject to the Authority approval.

The documentation schedule shall allow for at least two submissions of each document requiring review or approval. The time schedule for document review or approval by the Authority shall be as specified in this section.



### **1.5.2.Training Schedule**

The training schedule shall identify the dates of all of the training courses. The SI shall work with the Authority to determine the training schedule. The training schedule shall be subject to the Authority approval.

## **2. Hand-Over/Take Over (HOTO)**

SI will hand-over the system at the end of contractual period along with all documentation required to operate and maintain the system. It shall supply to the Authority the following before the expiry of the contract:

- Information relating to the current services rendered and data relating to the performance of the services; Entire documentation relating to various components of the project, any other data and confidential information related to the Project;
- All other information (including but not limited to documents, records and agreements) relating to the products & services of the project to enable the Authority and its nominated agencies, or its replacing Successful Bidder to carry out due diligence in order to transition the provision of the project services to the Authority or its nominated agencies, or its replacing Successful Bidder (as the case may be).

### 3. Operations & Maintenance

1. The operation & maintenance phase will be for seven (7) years from the date of Go-Live for the respective milestone. The Implementation Agency shall operate & maintain the network 24x7x365 following the defined SLAs.
2. The O&M contract can be extended for a further period as agreeable to both the parties at a mutually negotiated rate acceptable to both Authority and SI.
3. O&M would entail undertaking all activities to ensure uptime of the network as per agreed SLAs defined in this this Tender Document.
4. The SI shall prepare an operation & maintenance manual and submit to the Authority for approval. It shall cover the following, but not limited to:
  - o The details of the manpower deployment at the NOC, districts and field staffs for maintenance.
  - o The process/procedure for the periodical maintenance, problem resolution, fault rectification.
  - o The procedure/process for upkeep of NOC, PoPs, fibre infrastructure including periodical maintenance, problem resolution and fault rectification.
  - o Service provision/bandwidth & dark fibre provisioning as per requirement.
5. Resources for Operation and Maintenance of the active and passive network elements would include following but not limited to:
  - o Field engineers with dedicated FRTs (Field Restoration Team)
  - o SI may use two wheeler for patrolling and four wheeler for FRT teams having tools & mobilization of other necessary resources, communication devices to issue reporting and resolution.
  - o Equipment like splicing machine, OTDR, LSPM, Visual fault locators, Fibre optic cleaning kits etc. required for maintenance.
  - o Material storage locations with adequate capacity across the state to speed up material delivery during fault to reduce MTTR.
  - o Spare material including all required active and passive elements in adequate quantity to be maintained at all time at all storage locations.
  - o Field engineers with networking certification to maintain active elements of the network including replacement, installation, configuration and integration.
6. SI shall manage a 24x7 help desk at the NOC. SI shall also monitor and report the network utilization O&M shall also entail ensuring timely upgrade of infrastructure to meet the changing demand scenarios, maintenance & manage spares.
7. SI shall submit periodical reports against the SLA, periodical updating of the ABDs, NMS, BSS, Help desk reports, etc. as per requirement.

## 4. Training & Support Services

This section describes the requirements for SI-supplied training, support services and maintenance of the entire network system. The intent of the training and support program is to ensure a smooth transfer of systems and technologies from the SI to the KSEBL/Authority's employees, and to ensure that KSEBL/Authority's staff are fully trained to operate, maintain and expand the system.

### 4.1. Training

Training is an important aspect of this project, and the Authority expects the Successful Bidder to undertake it in a very professional manner. Bidder has to conduct a proper training need analysis of all the concerned staff and draw up a systematic training plan in line with the overall project plan. For all these training programs the Bidder has to provide necessary course material and reference manuals (user/maintenance/ administration) along with training schedules for all phases. The training shall be held at various office/department locations as finalised by the Authority.

The SI shall provide a comprehensive training program that prepares the KSEBL/Authority's personnel for on-site installation support, operation, and maintenance of the network. Successful Bidder shall arrange formal classroom trainings as well as field visits for the Authority's personnel. Training would cover the following areas, but not limited to:-

Training may be conducted by the SI, the SI's sub-contractors, and/or original equipment manufacturers (OEMs). The training requirements of this Specification shall apply to all such courses.

Training courses shall be conducted by personnel who speak understandable English and who are experienced in instruction. All necessary training material shall be provided by the SI. All charges for training materials and all associated expenses shall be borne by the SI. However all expenses of the KSEBL/ Authority participants will be borne by the KSEBL/ Authority.

Hands-on training shall be provided with equipment identical to that being supplied to the KSEBL/ Authority

The schedule, location and detailed training contents shall be submitted by the SI to the Authority for approval.

### 4.2. Overview Training

The training shall be oriented to a user's point of view. Authority/KSEBL's users will include managers, design & planning personnel, communication support staff and maintenance personnel.

The overview training shall be customized for the specific functions, features, and items purchased by the Authority; it shall not be a general presentation of the SI' standard equipment repertoire. Personnel assigned by the SI to implement the system shall conduct this overview training. The Authority shall review and approve the contents of the overview training at least four (4) weeks prior to the course.

The training courses shall also provide the KSEBL/ Authority's personnel with an in-depth working knowledge of the equipment, and operation of the test equipment / diagnostic tools. The courses shall provide personnel with a theoretical background and extensive hands-on experience.

### 4.3. Supervision, Maintenance and Installation Crew Training at Site

The Installation, Supervision & Maintenance training course shall enable the trainees to effectively supervise the fibre optic cable installation work, NOC monitoring, administering of network infrastructure, etc. from an Authority's perspective.

The training shall cover FO cable handling techniques, stringing and installation, jointing & splicing, OTDR use and OTDR trace analysis, power meter use, operation, preventive maintenance, troubleshooting procedures, corrective

## Volume- II

maintenance, expansion procedures, installation quality checks and safety procedures. It shall also cover an appreciation of restorative procedures required after any likely cable failure such as cable breaks due to storms or falling trees, installation hardware failures or misalignments.

Installation crew training shall be predominantly hands-on training courses provided for a group of persons. The intent of this training is to enable Authority to undertake maintenance & restoration work in case of cable breaks or other such failures, NOC monitoring, issue resolution at PoPs and offices, etc.

The SI shall submit for approval a detailed proposal for this training as per the agreed documentation schedule in consideration with following Authority's proposal. The proposal shall include information such as trainee profile, course duration, training facilities and methodology to be used etc.

### 4.4. Training Course Requirements and schedule (Authority's proposal)

Sl. No.	Details of course	Duration	No of participants	Location	Remarks
1	Overview Training	5 days	30	SIs premises	During Engineering period
2	Supervision , Installation and Maintenance Training	3 days	30	At site	Before starting Installation works
3	Supervision , Installation and Maintenance Training	3 days	30	At site	After two years

Table 104: Training Course Requirement

### 4.5. Manuals and Equipment

The SI, subSI, or OEM shall prepare training manuals and submit them to the Authority for review at least one month prior to the start of Supervision, Installation and Maintenance Training. The training manuals shall be prepared specifically for use as training aids; reference manuals, maintenance manuals may be used as supplementary training material. Principal documents used for training shall be tailored to reflect all the requirements specified by the Authority.

Each course participant shall receive individual soft copies of training manuals and other pertinent material at least two weeks prior to the start of each course. Fifteen (15) numbers of hard copies of all training manuals and materials shall be submitted to Authority as reference documentation.

The SI shall bring all special tools, equipment, training aids, and any other materials required to train participants during training courses.

### 4.6. Support Services

Throughout design, implementation, factory testing, and field installation and testing, the SI shall supply consulting assistance, as required by the Authority for site preparation, field installation, and other areas where technical support may be required.

#### 4.6.1. Technical Support

Consultation with SI's technical support personnel and trained field service personnel shall be readily available on a short-term/long-term basis to assist the Authority's personnel in maintaining, expanding, and enhancing the telecommunication network upon expiration of the warranty period. The SI shall include in their offer(s), a proposal for ensuring continued technical support as stated above.

## 5. Inspection & Testing

### 5.1. General Requirements

All materials furnished and all work performed under this Contract shall be inspected and tested. Deliverables shall not be shipped until all required inspections and tests have been completed, and all deficiencies have been corrected to comply with this Specification and approved for shipment by Authority.

Except where otherwise specified, the SI shall provide all manpower and materials for tests, including testing facilities, logistics, power and instrumentation, and replacement of damaged parts. The costs shall be borne by the SI and shall be deemed to be included in the contract price, except for the expenses of Authority's representative.

Acceptance or waiver of tests shall not relieve the SI from the responsibility to furnish material in accordance with the specifications.

All tests shall be witnessed by the Authority unless the Authority authorizes testing to proceed without witness. The Authority's representative shall sign the test form indicating approval of successful tests.

Should any inspections or tests indicate that specific item does not meet Specification requirements, the appropriate items shall be replaced, upgraded, or added by the SI as necessary to correct the noted deficiencies at no cost to the Authority. After correction of a deficiency, all necessary retests shall be performed to verify the effectiveness of the corrective action.

The Authority reserves the right to require the SI to perform, at the Authority's expense, any other reasonable test(s) at the SI's premises, on site, or elsewhere in addition to the specified tests to assure the Authority of specification compliance.

### 5.2. Inspection

Access to the SI's facility during system manufacturing and testing and to any facility where systems/equipment are being produced / tested / integrated for the network shall be available to the Authority. At all times, Authority/agencies or officials designated by Authority shall have full facilities for unrestricted inspection of such materials or equipment. To facilitate this, SI shall submit for the Authority's approval, a comprehensive quality assurance plan using ISO 9000 as a general guideline. In addition, the QAP shall satisfy the following;

- a) Sufficient office facilities, equipment and documentation necessary to complete all inspections and to verify that the equipment is being fabricated and maintained in accordance with the specification
- b) Authority reserves right to conduct physical inspection of the equipment (active/passive) delivered to ensure that they arrive at the sites in good condition and are free from physical damage and incomplete shipments and shall return the products to the supplier at the supplier's expenses if required quality is not maintained. Physical inspection will also include physical checking and counting of the delivered equipment in presence of the SI. SI's documentation will also be examined to verify that it adequately identifies and describes all offered items and spare parts.
- c) Access to inspect the SI's standards, procedures, and records that are applicable to the supplied equipment shall be provided to the Authority. Documents will be inspected to verify that the SI has performed the required quality assurance activity.
- d) The inspection rights described above shall also apply to sub-contractors whoever responsible for supplying major components described in the specification. These items shall be inspected and tested at the OEM's factory by the Authority's representatives prior to shipping this equipment to the SI's facility or directly to the Authority.

- e) The above inspection rights shall also apply to sub-contractors supplying assemblies, subassemblies and components. However such items will normally be inspected and tested by the Authority 's representatives at the SI's site before acceptance

### **5.3.Test Plans and Procedures**

Test plans and test procedures shall be provided by the SI. It shall ensure that each test is comprehensive and verifies all the features of the equipment to be tested. Test plans and test procedures shall be modular to allow individual test segments to be repeated upon request. The Authority in consultation with the PMA shall review and finalize the detailed acceptance test plan proposed by the SI. The Authority would also conduct audit of the process, plan and results of the Acceptance Test carried out by the SI for both IT & non-IT components. For both IT & Non-IT equipment, software manuals / brochures / Data Sheets / CD / DVD / media for all the project supplied components should be submitted to the Authority.

The SI shall give the Authority twenty one (21) days written notice of any material being ready for testing and Fifteen (15) days prior to the scheduled testing. Authority shall provide written notice to the SI of any drawings, equipment, material, or workmanship in which the Authority's opinion, are not compliant to the specification. The SI shall give due consideration to such objections, if valid, effecting the corrections as necessary or shall prove, in writing, that said modifications are unnecessary for contract compliance.

#### **5.3.1.Test Plans**

A test plan for all tests (factory, site and final acceptance) shall be submitted for the Authority approval, at least four (4) weeks before the start of testing. The test plan shall be a single overview document that defines the overall schedule and individual responsibilities associated with conducting the tests, documenting the test results, and successfully completing the test criteria. Test Plans shall include, at a minimum, the information contained in table below.

<b>Item No</b>	<b>Description</b>
1	Test schedule
2	Record-keeping assignments, procedures and forms
3	Procedures for monitoring, correcting and re-testing variances
4	Procedures for controlling and documenting all changes made to the equipment after the start of testing

*Table 105: Test Plan*

#### **5.3.2.Test Procedures**

Test procedures shall be submitted for the Authority's approval at least four (4) weeks before each individual test. Testing shall not commence without approved test procedures. At a minimum, test procedures shall include the items listed in the table below.

All test equipment and/or instruments shall bear calibration stickers indicating valid calibration on and beyond the testing date. The time elapsed since last calibration shall not exceed the test equipment/ jig manufacturer recommended calibration interval or the interval recommended in the test lab's internal quality procedures.

The SI shall ensure that all testing will be performed by qualified testing personnel well experienced in performing such tests.

<b>Item No</b>	<b>Description</b>
1	Test Title and Revision Level, if applicable
2	List of Standard(s) complied with
3	Function(s) / parameter(s) to be tested
4	Purpose of each test segment
5	List of required test equipment
6	Description of any special test conditions or special actions required. This includes complete descriptions, listings and user interface procedures for all special hardware and software tools and/or display formats to be used during the test.
7	Test setup including test configuration block diagrams and/or illustrations.
8	Test procedures to be followed.
9	Required inputs and expected outputs for each test segment
10	Acceptance criteria for each test segment.
11	List of test data to be supplied by the SI(s) and copies of any certified data to be used
12	Format of test re-ports.

*Table 106: Test Procedure Requirements*

### **5.3.3.Test Records**

Complete and indexed records of all test results shall be maintained and provided to the Authority by the SI in hard & soft copy. The records shall be keyed to the steps enumerated in the test procedures. The minimal items required in test records are described in the table below

<b>Item No</b>	<b>Description</b>
1	Test Title and Revision Level, if applicable; contract references
2	Date and time for test start and test completed
3	Test title and reference to the appropriate section of the test procedures
4	Description of any special test conditions or special actions taken (includes test-case data).
5	Test results for each test segment including an indication of Passed, Conditional Pass, Incomplete or Failed.
6	Test procedure modifications made during testing.
7	Variance Report(s) tracking information and copies (if variance(s) was detected).
8	SI's test engineer(s) identification, signature and remarks
9	Authority's test witness identification, signature and remarks
10	List of all attachments



Item No	Description
11	Attachments (including system logs, printouts, variances, hard copies of visual test result displays, etc.)

*Table 107: Test Record Requirements*

All test records, test certificates and performance curves shall be supplied for all tests carried out as proof of compliance with the specifications and/or each and every specified test. These test certificates, records and performance curves shall be supplied for all tests, whether or not they have been witnessed by the Authority within the specified duration after the completion of test. Information given on such test certificates and curves shall be sufficient to identify the material or equipment to which the certificates refer, and shall also bear the SI's reference and heading.

### **5.3.4 Rejection of Elements**

Any item or component which fails to comply with the requirements of this Specification in any respect, at any stage of manufacture, test, and erection or on completion at site may be rejected by the Authority either in whole or part as considered necessary.

Material or components with defects of such a nature that do not meet the requirements of the Specification by adjustment or modification shall be replaced by the SI at his own expense. After adjustment or modification, the SI shall submit the items to the Authority for further inspection and/or tests.

### **5.4. Acceptance Testing**

The Acceptance Test for the Project shall be carried as per the phases defined in this tender document by an Independent Evaluation Agency - Project Monitoring Agency (PMA) appointed by the Authority. The Successful Bidder should cooperate with the PMA to ensure successful completion of acceptance tests. The PMA shall verify availability of all the defined services as per the contract signed between the SI and the Authority. The SI shall be required to demonstrate all the services, features, functionalities as mentioned in the agreement.

Commissioning shall involve the completion of the site preparation, supply and installation of the required components and making the project available to the Authority for carrying out live operations and getting the acceptance of the same from the Authority. Testing and Commissioning shall be carried out before the commencement of Operations. Acceptance Test shall involve scrutiny of documents for various IT / Non-IT components to verify if the specifications conform to the technical and functional requirements mentioned in the Tender and subsequent corrigendum, if any. Bidder should conduct its own checks against documents/data sheets sheets/user manuals of corresponding OEMs for all items proposed under their solution in this bid. Bidder shall make one or more of these supporting documents available to the client's authority and prove the compliance of items supplied under this project against technical and functional requirements mentioned in the Tender. This equipment will only be acceptable as correct when each received item corresponds with the checklist (prepared by SI and approved by PMA) prior to shipment. Any shortfalls in terms of number of items received may render the delivered equipment incomplete.

The Acceptance shall cover 100% of the project implementation scope, after successful testing by the PMA appointed by the Authority. The Acceptance Test Certificate shall be issued by the PMA approved by the Authority to the SI. The AT shall include the following:

1. All hardware, software, passive items must be installed at respective sites as per the specification.
2. Availability of all the defined services shall be verified.
3. The SI shall be required to demonstrate all the features / facilities / functionalities as mentioned in the RfP.
4. The SI shall arrange the test equipment required for performance verification, and will also provide documented test results.
5. The SI shall be responsible for the security audit of the established system to be carried out by a certified third party as agreed by the Authority.

## Volume- II

---

6. In case of any dependency on client/un-attributable circumstances, w.r.t achievement of above milestones, unresolved beyond a reasonable time frame, the technical committee appointed by the client may provide part acceptance for successfully implemented components in the overall interest of the project progress.

Any delay by the SI in the Acceptance Testing shall render him liable to the imposition of appropriate penalties. However, delays identified beyond the control of SI shall be considered appropriately and as per mutual agreement between the Authority and SI.

The Acceptance Plan proposed by the Authority is given in the Appendix.

## **6. Documentation and Deliverables**

This section describes the documentation requirements and provides a list of deliverables that the SI shall provide to the Authority - complete documentation necessary for the operation and maintenance of both the projects. All the documentation shall be provided in hard copy and also soft copy in full compliance with the specification.

Conditions pertaining to Document Review and Approval Rights and Document Submission Scheduling are also specified in this Section.

As detailed in subsequent sections the documentation shall include the following:

- (a) Inception Report
- (b) Detailed list of the deliverables
- (c) Site Survey Reports
- (d) Description of the products
- (e) Technical Architecture Report
- (f) Technical particulars
- (g) Installation manuals
- (h) Maintenance manuals
- (i) Quality assurance manuals, Manufacturing Quality Plan (MQP) & Field Quality Plan (FQP)
- (j) Tests (type test, production, FAT, SAT, Acceptance) documentation

### **6.1. System Documentation**

A detailed documentation plan and document submission schedule shall be prepared and submitted to Authority for approval.

### **6.2. Supplementary Documentation**

If during the training courses or while performing maintenance on equipment during the warranty period, the Authority determines that additional information is required to perform the maintenance function, the SI and/or its sub-contractors shall provide the specific supplemental information necessary to perform the maintenance function. This information shall be documented in a form suitable for incorporation into the appropriate maintenance document.

### **6.3. Test Documentation**

The SI shall provide documentation for all type test, factory acceptance test (FAT) and site acceptance tests (SAT).

The test documentation shall include the following:

- (a) Test Procedure Document
- (b) Type test documents
- (c) Factory Acceptance Test Documents
- (d) Site/Acceptance Test Documents

### **6.4. Drawings**

All drawings submitted by the SI including those submitted at the time of bid shall be in sufficient detail to indicate the type, size, arrangement, dimensions, material description, Bill of Materials, weight of each component, break-up for packing and shipment, shipping arrangement required, the dimensions required for installation and any other information specifically requested in the Specifications.

Each drawing submitted by the SI shall be clearly marked with the Authority/KSEBL's name, the unit designation, the specification title, the specification number and the name of the Project. All titles, notes, markings and writings on the drawing shall be in English. All the dimensions should be to the scale and in metric units. The drawing revision

level/ issue no, issue date shall be marked on each drawing and the drawing shall carry issue history information and appropriate signatures (eg: originator, checker and approving authority).

### **6.5. Drawing and Document Approval Procedure**

The drawings/documents submitted by the SI shall be reviewed by the Authority or its appointed agencies as far as practicable within stipulated duration and shall be modified by the SI if any modifications and/or corrections are required by the Authority in compliance with the Specifications. The SI shall incorporate such modifications and/or corrections and submit the final drawings for approval. Any delays arising out of failure by the SI to rectify the drawings in good time shall not alter the contract completion date.

The drawings/documents submitted for approval to the Authority shall be in triplicate. One print of such drawings shall be returned to the SI by the Authority marked with one of the categories as listed below:-

Cat I	Approved/Released for implementation.
Cat II	Approved/Released for implementation subject to incorporation of comments. Revised drawing required.
Cat III	To be resubmitted for approval after incorporating comments.
Cat IV	For information and record

*Table 108: Documentation Categories*

The approval of the drawing/document conveyed vide above marked copy shall neither relieve the SI of its contractual obligations and its responsibilities towards weights, qualities, design details, assembly fits, performance particulars and conformity of supplies with the Indian Statutory Laws as may be applicable, nor shall it limit Authority's right under the contract.

Depending upon the category of approval the SI shall resubmit the drawings/documents for review by Authority after incorporating all corrections.

Further work by the SI shall be strictly in accordance with the Cat-I, Cat-II or Cat-IV approved drawings and no deviation shall be permitted without the written approval of the Authority.

All manufacturing and fabrication work in connection with the equipment/material prior to the approval of the drawings shall be at the SI's risk. The SI may make any changes in the design which are necessary to make the equipment/material conform to the provisions and intent of the Contract and such changes will again be subject to approval by the Authority.

Approval of SI's drawing or work by the Authority shall not relieve the SI of any of his responsibilities and liabilities under the Contract.

### **6.6. Final Documentation**

Final documentation shall consist of the documents approved in Cat I and Cat IV. The documents will be used by the Authority's personnel or its appointed agencies for operating and maintaining the equipment after acceptance.

Until acceptance of the equipment by the Authority, the SI shall be responsible for supplying documentation revisions or changes necessitated by inaccuracies, installation requirements, omissions determined by usage, and design or production alterations to the equipment. All changes shall be issued in the form of replacements for the affected

## Volume- II

drawings, diagrams, charts, graphs, tables, lists, and pages in the various documentation such that all documentation describes the equipment "as delivered".

For all Cat I and Cat IV approved documents listed in the below table (except Type, FAT & SAT related), Five (5) sets of the final approved documentation shall be provided to the Authority in hardcopy and two sets in softcopy. The list given in the below table is tentative which shall be finalized during detailed engineering.

All final SI-supplied documentation shall be easily reproducible by the Authority.

SL No	Document	Applicable Equipm item	Brief Description	Category of Approval
1.	Inception report		This document shall contain Scope, Assumptions, dependencies and constraints, Solution architecture, Project approach, project schedule and Deliverables, WBS, Team structure, Manpower, Communication and review plan, Risk management, Project monitoring, etc.	I
2.	Documentation plan & schedule		This document shall contain the list of all documents to be submitted for approval and their submission/ approval schedule	I
3.	Survey guidelines & formats		As per Technical specifications	I
4.	Detailed Technical Architecture Report		Based on the site survey, the detailed technical architecture of the entire system for both packages incl. system architecture diagrams shall be submitted	I
5.	Data Requirement Sheets (DRS) and Guaranteed Technical Parameters & Drawings	For each and every item to be supplied including OFC, OPGW Cable, OF Approach Cable, UG OFC, Optical hardware, FODP, etc.	These describe parameters of the equipment being offered. The DRS shall be submitted for all the items and supported by Technical brochure/Product manual.	Cat-I(for DRS) & Cat-IV (for brochure
6.	Sag Tension charts	For OPGW, OFC cables	Shall accompany the DRS document	I
7.	Standard Documents	For all items	Complete set of all manuals for that product. A set of product brochures, photographs etc.	IV
8.	Previous type test reports	For all items for which type testing is envisaged	Shall be complete in all respect including all test graphs, curves, calculations, photographs etc.	Acceptance letter by Authority
9.	Type test procedures	For all items for which type testing is required	Shall be formatted as per the technical specifications	I
10	Manufacturing Quality Plan	For all items to be supplied		I

**Volume- II**

<b>SL No</b>	<b>Document</b>	<b>Applicable Equipm item</b>	<b>Brief Description</b>	<b>Category of Approval</b>
11	Type test schedule	For all items for which type testing is required.	Shall indicate the start & finish data for each test & sequence of tests if applicable, test labs.	I
12	Type test report	For all items for which type testing is required.		Acceptance letter by Authority
13	Transmission/ HT/LT/Distribution Line , and other route survey reports and engineering analysis	For each FO cable link	Line wise survey reports indicating tower/pole schedules, drum schedules, crossing details, hardware & fitting requirements etc. Shall include line wise sag-tension charts and other engineering analysis such as tower/pole strengthening analysis etc.	I (for drum schedule) and IV for other detailed report
14	Link and site survey reports & engineering analysis	For each Fibre Optic link and site	Milestone wise survey reports incl. link wise as specifications, link calculations etc.	I
15	Bill of Quantity	For each item and each line		I
16	Factory Acceptance tests: test plan, procedures and report format	For all items to be supplied	This document shall include the list of Factory Acceptance Tests, the administrative & functional test plans, test procedures and formats for recording & reporting factory acceptance test results.	I
17	Factory acceptance test report	For all Factory acceptance tests		Acceptance letter by Authority
18	Transportation & Handling Procedures	For all items	This document shall describe the procedures & precautions to be observed during overseas & inland transportation, equipment handling during transport, storage & include packing details and pre-installation. It shall also package labelling details.	IV
19	Manual	Cable/Hardware/Software	Installation & O&M activities description	I
20	Jointing Manual	For each type of FO cable/joint box to be supplied	This document shall describe the installation of joint box (splice enclosures) and other jointing gang activities	I

**Volume- II**

SL No	Document	Applicable Equipm item	Brief Description	Category of Approval
21	Site Acceptance tests (SAT) test plan, procedures and report format	System document	This document shall include the list of Site acceptance tests, the administrative & functional test plans, test procedures and formats for recording & reporting site acceptance test results. This document shall be restricted to describing the acceptance tests listed in this technical specification, and other similar tests which shall be conducted in Authority's presence for Site acceptance.	I
22	Field Quality Plan	One Document with multiple subdocuments if required	Field Quality Plan shall describe the quality control to be exercised during the field activities. This document can include the following information: (a.) The list of performance & safety checks applied to installation equipment, tools & tackles, checks, check on physical health & training records of installation crew etc. (b.) The list of Site Acceptance tests (including statement of acceptance criteria). The list of site acceptance tests in FQP is analogous to the inclusion of list of FAT in the MQP. The formats for recording & reporting Site acceptance tests can also be reproduced	I
23	Approach Cable/ UG OFC Installation Document General	Approach cable/UG OFC	This document shall describe the general approaches to be adopted for installation of Approach cables, for example the document shall try to answer questions such as whether cable trenches or cable raceways shall be used? Or whether any conduits/ ducts will be used, if so, of what type? etc. In case of UG OFC how many manholes are required, route indicators, what type, duct laying practices, its type, etc.	Cat- I
24	Approach Cable/ UG OFC	For each site & FODP layout document- site wise Areas where laying of aerial OFC is not possible	To describe the layout of approach cable at each site and the floor plan of the FODP. Describe the layout of UG OFC	Cat- I
25	Training	System document Manuals	An advance copy of all training material.	IV
26	Maintenance Philosophy & Procedures	System document	Shall cover breakdown maintenance procedures, preventive maintenance schedules and procedures	IV

**Volume- II**

SL No	Document	Applicable Equipm item	Brief Description	Category of Approval
27	SAT reports	Per Link		Acceptance letter by Authority

*Table 109: Documentation Plan*

SL No	Chapters	Description
1	Installation procedure	For all the active/passive systems Description of activities of installation: Preparation & Setting up, Stringing, sagging, attaching hardware, attaching down lead clamps & cable routing on the tower, securing cable ends (for protection before work by jointing gang). Precautions for preventing cable damage shall be highlighted. Installation of software and other hardware components
2	Safety Instructions	Instructions & procedures related to ensuring installation crew safety: personnel grounding & safety, installation equipment safety, Safety for power system & environment (viz preventing accidental tripping, precaution for railway crossings etc)
3	Description of Installation Equipment	Sketches, drawings, photographs, safe working ratings of installation equipment, tools & tackles etc., handling instructions & precautions.
4	Cable layout	Illustrations of the positions of tower attachment clamps (down lead clamps), routing of FO cable on the tower, service loop(s), joint box position. References to other related documents covering the test - Shall submit the detailed cabling layout including cable routing, telecommunication closets and telecommunication outlet/ connector designations. The layout shall detail locations of all equipment and indicate all wiring pathways.
5	References	installation, jointing & testing, such as SAT administrative & functional test plans & procedures Jointing Procedures Field Quality Plan & Field Quality Audit Storage & Handling Instructions FO cable & hardware drawings, technical parameters, DRS etc. Authority & Statutory safety rules, safety manuals, standards, codes of practices etc.

*Table 110: Expected Contents & Structure of FO Cable Installation Manual for Overhead FO cable*

**Note**The Successful Bidder will ensure upkeep and updating of all documentation and manuals during the contractual period. The ownership of all documents, supplied by the Successful Bidder, will be with Authority.



## **7. Health, Safety and Environmental Plan**

The health and safety requirements are the minimum for the SI employed to do construction works. Authority's requirements, SI's own standards, local regulations or laws may stipulate higher, and or additional requirements, the higher standard shall always be followed. These requirements form an integral part of the contract between Authority and the SI.

It is the SI's responsibility to ensure that the Health, Safety and Environment planning requirements are implemented and followed by his employees and of all who may be affected by the construction works.

### **7.1. Contract Conditions**

The conditions set out in this document shall form an integral part of the contract between Authority and the SI. They shall apply to all SIs throughout the duration of the contract, to ensure that the work is completed without any risk or liability to Authority or third person.

### **7.2. General Requirements**

The SI is responsible to follow and further develop the content of these health and safety requirements in his own plan, and to comply with the elements of Authority's Construction Health and Safety Plan.

SI's shall:-

- (a) Ensure the tender is based on compliance with the requirements of this HSE plan
- (b) Prepare and maintain a construction Health care and safety plan, aligned to Authority's. The SI shall submit the same to Authority at least 21 days prior to the scheduled start date on site
- (c) Complete risk assessments for all assigned activities of the project and provide safe method statements. Method statements shall be submitted at least 21 days before planned start of the work activity, for approval by the Authority.
- (d) Identify all potential emergency situations regarding health, safety and environment aspects in all activities at site and have emergency action plans for these situations.
- (e) Ensure that all his sub-contractor's personnel working at site are informed/ consulted in health, fire safety, labour safety and environmental aspects and trained in how to avoid health, safety and environmental damage caused in own work procedures.
- (f) Ensure that all of his and his sub-contractor's personnel working at site comply with the requirements set out in this document.
- (g) Ensure that all of his and his sub-contractor's personnel working at site have adequate training and information of Live Electrical Working and/or near of Electrical Working hazards.
- (h) Ensure that ID/Names of all of his and his sub-contractor's personnel are available at SI's site management
- (i) Ensure that competent and adequately resources are used by himself and his sub-contractors
- (j) Ensure, when appointed as SI that co-ordination of activities are completed to ensure effective project execution.
- (k) Ensure that only authorized persons enter the site and that they are given a health and safety induction/orientation training that includes requirements of the construction health and safety plan, and this instruction.
- (l) Maintain a high standard of housekeeping, and cleanliness on site.
- (m) Appoint a named health and safety advisor to co-ordinate and monitor the site works in line with the health, safety and environment requirements
- (n) Ensure liability insurance for his activity.

The above requirements shall be reviewed in the periodical progress review meetings.

### **7.3. Reporting of incidents, and hours worked**

All incidents and hours worked shall be reported to the Authority.

Incident records shall as a minimum contain the following:

- I. Project and site,
- II. Date and time
- III. Incident type and description, related circumstances must be documented, main cause of the accident, first aid related measures etc.
- IV. Root causes and corrective actions taken
- V. Responsible person for corrective actions,
- VI. Signed report with photographs if available

### **7.4. Non-compliance**

The Authority's representative shall:-

- a. have the power to exclude any person from the site, after reasonable warning, if that person is deemed to be non-compliant with the requirements of this document, and/or are working unsafely. There shall be no cost to Authority as a consequence.
- b. have the power to stop work at any time if of the opinion that the SI is working unsafely, or where there is a significant risk to others who may be affected by the work or to the environment, or where the SI is in direct contravention with the requirements of this instruction. In such circumstances the SI shall bear any costs that may arise as a result of not being able to complete the work at the time.

### **7.5. Site Health and Safety Controls**

#### **7.5.1 Project Planning**

The SI shall have a formal health and safety management system that ensures the creation of project health and safety plans that achieve the requirements of this document.

- (1) Only trained for the related hazards, qualified, personnel are allowed to work on or near installations energized or capable of being energized.
- (2) It is the responsibility of the site engineer of the SI working in a site to make sure that they have a written work permit / live line permit from the KSEBL
- (3) During cable laying work, which have to be done in close proximity to live parts the site Engineer shall ensure the men, material etc. are within safe limits.
- (4) When working in substations, demarcation of a work area is one of the main control measures to ensure clear boundaries between safe and unsafe workplaces. The site engineer shall arrange shutdown permit work from KSEBL in case live line work is not safe in substation area.
- (5) Before vehicles and heavy machinery are allowed to enter into live areas the site engineer of the SI shall ensure that sufficient clearance from overhead lines are maintained.
- (6) Power supply to all electrical equipment and hand tools shall be provided with a ground fault circuit interrupter.
- (7) Personal Protective Equipment:- Approved PPE shall be worn by all the working team members of the SI during installation works such as hard hat, safety foot wear, safety belt, high visibility safety vest and any other PPE required for the work.
- (8) While pulling cable and during removal of earth wires through towers the site Engineer shall ensure that the earthing /grounding had provided through running earthing arrangement.
- (9) The site engineer shall ensure that the winch load shall be in safe limit while pulling the cable.

## Volume- II

---

- (10) On no account is lone working is permitted even if other people are working on or near to electrical installations.
- (11) While pulling cable across EHT lines, the site engineer of the SI shall ensure that necessary additional precautions due to induction from EHT lines.
- (12) While pulling cable over EHT/HT/LT lines, the site engineer of the SI shall ensure that all the above lines are under shutdown condition during pilot wire pulling using traction machine in that line span.
- (13) It is the responsibility of the Site Engineer of the SI to check the condition of existing clamps on earth wire / earth wire is sufficient to take the load of pulling traction machine. In case the clamps are found weak, additional support clamp shall be provided temporarily. If the earth wire is found weak, shut down permit shall be arranged from KSEBL.

## Annexure I - Installation Guidelines for ADSS Cable

This section is intended to provide guidelines for selection of appropriate methodology for aerial installation of ADSS optical fibre cable on existing electrical poles of 33kV, HT & LT lines.

Additional poles should be erected if required to keep the span length within the specified limits. Care should be taken that the alignment is easily accessible from the road.

### **Installation Techniques**

The techniques used in installation of Aerial ADSS Optical Fibre Cables are described here. With the proper installation hardware and skilled resource, any of these methods can be used to install ADSS cable. Many a times, it will become necessary to use a combination of these methods to achieve full installation.

Selection of the specific technique (i.e. Moving Drum method, Stationary Drum method or Manual Installation method), or a combination thereof, shall largely depend on the actual site conditions. The SI shall select the most appropriate installation technique suitable to the site conditions.

- a. ***Moving Drum Method*** This method the cable is pulled directly from the cable drum mounted on a moving vehicle as it drives along the pole line. The cable drum must be mounted on a proper support to allow easy cable pay off. At the dead-end point, the cable is terminated using Termination Assembly sets and tensioned using turnbuckles to maintain cable sag within permissible value.

To start installation, park the vehicle with the cable drum approximately 15 - 20 meters away from the pole facing away from it down the pole line. The cable must pay off from top of the drum towards the rear of the vehicle.

Install the termination supports and temporary hooks on the poles at the starting point and subsequent poles. Pull off the necessary amount of slack, lift the dead-end to the top of the pole and mount on the termination assembly.

Once the cable is fixed at both ends with at the terminating assemblies, carry out tensioning. After the cable section is properly tensioned and secured at both ends lift the cable out of the hooks at each of the intermediate pole and support it with the suspension set assemblies.

- b. ***Stationary Drum Method*** This method of aerial cable installation, the cable is pulled along the cable route through temporary support hardware. Stationery drum installation method requires installation of temporary support hardware such as pulley blocks.

A rope wound on the tension limiting winch is passed through the pulleys and connected to the cable on the drum installed on a stand which allows free rotation of the drum. The pulling load should normally not exceed 60% of the maximum permissible cable tension recommended by cable supplier.

The cable drum and winch locations must have vehicular access. The cable drum should always be placed on levelled ground so that its flanges are vertical thus avoiding rubbing of cable against flanges. The orientation should be such that the cable pay-off is directly in the direction of pull. Always pay-out the cable from top of the drum and not from bottom. The drum should have provision to allow controlled pay-out of cable. Cable pay-out needs to be controlled to prevent free running or jerking.

Once the cable is completely pulled end to end, it is then ready for installation of permanent supporting system of terminating and suspension set assemblies at required locations and tensioning for sag control.

- c. ***Manual Installation Method*** Manual installation method technique is similar to stationary drum method, except that in this case the cable is uncoiled from the drum and placed on the ground in the shape of 8. The pulling operation is same as in stationary drum method. The hardware requirement and pulling equipment

## Volume- II

also remains same. For pulling in both directions, two loops of shape of 8 can be made and each can be pulled in separate directions. Loops of size 4 to 5m x 1.5m should be sufficient in most cases.

### **Machinery / Equipment / Tools:**

- ξ Ropes and light weight ladder for installation of termination/suspension assemblies, clamps etc.
- ξ Temporary supports, dynamometer, chain hoists, temporary dead ends, steel cables, etc. required during cable laying and/or cable pulling and cable tensioning operations as applicable will have to be arranged by the SI.
- ξ Van with portable splicing machines and OTDR, power meter, cable preparation kits, etc. for splicing and testing of installed ADSS Optical Fibre Cable.
- ξ Other tools and tackles shall include wrenches, spanners, screw drivers, hammer, ropes etc.
- ξ All safety equipment such as safety belts, insulating and cotton gloves and hard hats, fluorescent vests etc. as required

### **Live Line Installation Requirement**

All of the ADSS fibre cable under this project shall be installed under live line condition i.e. with all the circuits of the line charged to their rated voltage. The ADSS cable shall be installed on power transmission poles of voltage 33 kV and HT/LT distribution poles of 11kV and below. The SI shall carry out proper tensioning wherever required to maintain the adequate ground clearance and clearance from the live conductor. The detailed installation methodology shall be furnished in the detailed engineering and finalized with the Authority.

The installation shall be generally in accordance with the latest version of IEEE Guide to the Installation of Overhead transmission Line Conductor with additional instructions and precautions for live line working and fibre optic cable handling. The SI shall ensure that there shall be no outage of the distribution line during the live line stringing of ADSS cable and live line strengthening of the poles.

A minimum ground clearance of 3.05 m shall be maintained for the cable taken along the street concerned. A minimum vertical clearance of 1.2 m shall be maintained for cable from the lowest power conductor i.e. any functional conductor including that of the street main or any earthed conductor. When cables are drawn across the road, a minimum ground clearance of 5.8 m shall be maintained.

In order to safeguard against electric shock from lightning and the energized lines, the minimum safe distance from the electrified body must be in accordance with the stipulations in the below given table.

**Note** The Work rules of the NESC-230E1 Section 43 and 44 should be used to determine safe approach to live line systems.

Reference Voltage (kV)	Safe Distance(m) as per IEEE
0.415 – 11	0.7
11 – 35	1.0
35 – 60	1.2
60 – 100	1.5
100 – 154	2.0
154 – 220	3.0

Table 111: Minimum safe distance from live wires Reference Voltage (kV) Safe Distance (m)

### **Analysis for Support augmentation / strengthening**

After finalization of the ADSS cable design, analysis shall be carried out by the SI to ensure that with the stringing of ADSS cable, the pole remains stable as per the relevant standards. The bidder shall consider the requirement of such analysis to meet the specified requirement and no separate payment shall be payable for any design analysis for the poles / ADSS/underground armored optical fibres parameter finalization.

The successful bidder is required to provide pole strengthening mechanisms such as cross arms, pole stays/guys etc. to ensure that the safety of the existing power infrastructure is not compromised. This requirement has not been

## Volume- II

---

reflected as a separate item in the price schedule and therefore any costs associated with it should be included in the item price of other items included in the price schedule.

### **Steps recommended for installation**

The following steps are recommended:

1. The condition of the existing pole (damaged/ which require immediate replacement), reduced clearance/sag of the power line conductors against the standards, and any other such things which require rectification prior to OFC installation shall be recorded and submitted to Authority
2. Statutory clearance has to be maintained along the street and for road crossings. If there is no adequate statutory clearance in some road crossing locations, it would be better to go for a post insertion in such a way that the fibre can be drawn along the same side.
3. Recording of pole number should also be done for preparing the final schematic diagram in which the locations such as, road crossing portions, splice/splitter locations etc. shall be indicated.
4. Install the accessories and fixtures as per the requirement of the individual poles its tension and suspension fittings.
5. Install the pulley on all the poles in the section before pulling the cable.
6. Keep the cable drum over the jack near the 1st pole at the beginning of the section.
7. Attach anti twist device and the shackle hook along with the rope to the front end of the cable on pulling eye or on the cable grip. Carry the attached rope over the demountable pulleys for pulling the cable.
8. Depute one person at each pole to monitor and in case it is required to guide the cable over the demountable pulley during pulling operation.
9. The cable should be pulled till the cable reaches the last pole of the section.
10. Wherever in the pulling section; through pulling is difficult; half section or one fourth, action pulling method may be adopted by using figure of a techniques.
11. The feeding and pulling of the cable should be synchronized by using communication link. Care is required to be taken so that the cable is not accumulated at any one point during pulling operation and sharp bends are avoided.
12. Once the cable reaches the other end actual tensioning of the cable and fixing the installation of the accessories and fixtures shall be taken up with the help of cable pulling winch. The pulling tension must be monitored during tensioning.
13. Install the tension fittings and accessories at the 1st pole.
14. Fix a flat twin open type cable grip on the cable after tension pole for tensioning the cable in the preceding tension section.
15. The cable shall be tensioned to a tension of 1-3 to 1-6 times of the cable weight.
16. The sag shall be monitored and kept between 0.25 to 0.5% of the span length.
17. The cable should be lifted between two poles by using cable pole fork during tensioning and fixing of the cable.
18. During the fixing operation the cable shall remain under required tension for minimizing the sag in the splice section.
19. Now install tension fitting and accessories at the all tensioned pole at the end of the tension section.
20. Install the suspension fitting and accessories on the intermediate poles in the tensioned section.
21. Similarly installation should be carried out in each tension pole in the entire section and the tension and suspension fittings are installed.
22. At the tension poles the cable shall be kept loose and shall be supported by cable jumper clamp.
23. The fibre joint locations shall be identified for fixing outdoor splice boxes. The location of outdoor splice box is to be fixed at every fibre joint location. The fibre termination shall be made at the termination boxes provided at all locations where fibre is terminated such as horizontal offices etc. Splitter shall be provided in poles/locations as per the site requirements.
24. The location of the fibre slack (fibre loop for future maintenance) is to be decided and intimated in the survey report with necessary reference numbers after the detailed site survey. Based on the site conditions, the loop length shall be approximately 10% of sectional fibre length.
25. Test the installed OF cable.
26. Coil the OF cable and keep it safe in the splice location for splicing.

27. All the installation equipment must be kept, maintained and operated according to instructions of the manufacturer. All the disqualified equipment and tools, such as dropped, damaged or faulty ones shall be removed from site.

## Annexure II - Engineering Guidelines for UG Cable Laying

### 1. Optical Fibre Cable Laying Approach

Generally, Optical Fibre Cable may preferably be laid straight as far as possible along the road near the boundaries, away from the burrow pits. When the Optical Fibre Cable is laid along the National Highways, Cable should run along the road land boundary or at a minimum distance of 15 meters from the centre line of the road where the road land is wider as the OFC carries high capacity traffic and is planned for about 25 years of life. It is essential that the cable is laid after obtaining due permission from all the concerned authorities to avoid any damage (which may result in disruption of services / revenue loss) and shifting in near future due to their planned road widening works.

In special cases where it may be necessary to avoid burrow pits or low lying areas, the Cable may be laid underneath the shoulders at a distance of 0.6 meter from the outer edge of the road embankment provided the same is located at least 4.5 meters away from centre line of road.

### 2. General

**Soil Classification:** shall be classified under two broad categories Rocky and Non Rocky, The soil is categorized as rocky if the cable trench cannot be dug without blasting and / or chiseling. All other types of soils shall be categorized as Non Rocky including Murrum & soil mixed with stone or soft rock.

**Rocky soils:** the terrain which consists of hard rocks or boulders where blasting/ chiseling is required for trenching such as quartzite, granite, basalt in hilly areas and RCC (reinforcement to be cut through but not separated) and the like.

**Non Rocky soils:** will include all types of soil- soft soil/hard soil/Murrum i.e. any strata, such as sand, gravel, loam, clay, mud, black cotton murrum, shingle, river or nullah bed boulders, soling of roads, paths etc. (All such soils shall be sub-classified as kachcha soil) and hard core, macadam surface of any description (water bound, grouted tarmac etc.), CC roads and pavements, bituminous roads, bridges, culverts (All such soils shall be classified as Pucca soils)

### Laying of the Optical Fibre Cable

The Optical Fibre Cable shall be laid through PLB HDPE Ducts buried at a nominal depth of 165cm. The steps involved in Optical Fibre Cable laying are as under:

- § Excavation of trench up to a nominal depth of 165 cm in non-Rocky soil, according to construction specifications along National/State Highways/other roads and in built up /rural areas. Under exceptional conditions/ genuine circumstances due to site constraints/ soil conditions, relaxation can be granted by the competent authority for excavation of trench to a depth lesser than 165cm. Such relaxation shall be given as per the laid down norms/ procedures being set by Authority and with the approval of the competent authority. The payment in such cases shall be made on pro-rata basis as per the laid down norms adopted by the Authority.
- § Laying of PLB HDPE Ducts/coils coupled by sockets in excavated trenches, on bridges and culverts, as per construction specification and sealing of PLB HDPE Ducts pipe ends at every manhole by end -plugs of appropriate size. Optical Fibre Cables should be blown through Permanently Lubricated HDPE Duct of 40 mm-OD and 33 mm ID Pipe of 500/1000 meter coil which meets the specification as given in G/R No-G/CDS-08/02 Nov 2004 with latest amendments shall only be used for laying the OFC. Wherever DWC pipe or GI pipes or R.C.C. pipes are used for protection, the two ends of the pipes should be properly sealed to protect HDPE pipe from sharp edge of GI pipe and to bar the entry of rodents. For providing additional protection Split RCC/GI pipes should be used from top instead of full RCC/GI pipes.
- § Providing additional protection by R.C.C. Pipes/ GI pipes and/or concreting/chambering, wherever required according to construction specification.



- § Fixing of GI pipes/troughs with clamps on culverts/bridges and/or chambering or concreting of G.I. Pipes/troughs, wherever necessary. Normally, RCC/DWC pipes shall be used and use of GI pipes shall be avoided. However, in case it is felt that GI pipe is unavoidable in certain circumstances this should be done with the prior approval of competent authority within the concerned Authority. This shall be recorded appropriately.
- § Laying Protection Pipes on Bridges and Culverts. In case trenching and pipe laying is not possible on the culverts, the pipes shall be laid on the surface of the culverts/bridges after due permission from the competent authority within the concerned Authority as per construction specification.
- § Back filling and Dressing of the Trench according to construction specifications.
- § Making manhole of size (2.0 m length x 1.0 m width x 1.65 m Depth) at every Cable pulling location for housing the Optical Fibre Cable loop & Pulling Optical Fibre Cable using proper tools and accessories. Sealing of both ends of the PLB HDPE pipe in manhole by hard rubber bush of suitable size to avoid entry of rodents into the PLB HDPE Ducts, putting split PLB HDPE Ducts and split RCC pipes with proper fixtures over cable in the manhole to protect the bare cable.
- § Digging of pit of size 2 meter x 2 meter x 1.8 meter (depth) for fixing of Jointing chambered-cast RCC cover or stone of suitable size on jointing chamber to protect the Joint and backfilling of jointing chamber with excavated soil.
- § Digging of pits 500 cm to 1000 cm towards jungle side at every manhole and jointing chamber along the route to a depth of 75 cm fixing of route Indicator/joint indicator, concreting and backfilling of pits. Painting of route indicators with Blue colour and joint Indicator by Grey colour and sign writing denoting route/joint indicator number, kilometre, and marked as decided by Authority, as per construction specification.

### 3. Duct integration Test (DIT) for HDPE ducts

- § SI shall ensure that the trench does not have any sharp bend and the couplers are tightened to the maximum.
- § SI shall ensure the backfilling and the compaction of the trench are satisfactory prior to start of DIT.
- § SI shall ensure to pass the compressed air at 8Kg/Sq.cm and clean the duct from deposits like mud and small stones.
- § SI shall insert a medium density sponge into the duct and push it with compressed air of 8Kg/Sq.cm. The sponge should eject with full force.
- § The mandrill made of hard rubber or polished wood in the shape of cylinder of diameter 0.75 x D in diameter of HDPE duct and 75 mm long shall be used.
- § On completion of test seal the ends with end plugs.
- § SI shall ensure that there is no pressure leakage during DIT

### 4. Method of Blowing of Fibre Optic Cable through HDPE duct

- § SI shall ensure the duct Integrity test has been completed.
- § Drum should be kept approximately at the center of two adjacent chambers. (I.e. if drum length is 4 Km, at 2 Km.) So that on either side 2 Km blowing can be done.
- § Cable drum should be mounted on jack, which shall be kept on a plain surface.
- § Cable blowing to be done with the help of compressor, hydraulic power pack and blowing Machine. Anti-twist tool can be used to avoid twisting of cable while blowing.

### 5. Stripping/Cutting of the Cable

- § The cable is stripped of their outer and inner sheath with each sheath staggered approximately 10mm from the one above it.

- § Proper care must be taken when removing the inner sheath to ensure the fibres are not scratched or cut with the stripping knife or tool to prevent this, it is best to only score the inner sheath twice on opposite sides of the cable, rather than cut completely through it. The two scores marking on either side of the cable are then stripped of the inner sheath by hand quite easily.
- § The fibres are then removed from cable one by one and each fibre/ribbon is cleaned individually.

### 6. Material for Providing Additional Protection

- § RCC Full Round Pipes: Reinforced cement concrete pipes (spun type) coupled with RCC collars sealed with cement mortar used to provide additional protection to PLB HDPE Ducts/coils at lesser depths should be of full round, NP-2 class and size 100 mm (internal diameter), conforming to IS standard 458-1988 with latest amendments. The pipes should have a nominal length of 2 meters.
- § The RCC collars should be properly sealed using cement mortar 1:3 (1:53 grade cement of reputed brand, 3: fine sand without Impurities). If case of long spans, every third joint will be embedded in a concrete block of size 60 cm (L) x 40cm (W) x 25 cm (H) of 1:2:4 cement concrete mix (1: cement, 2: coarse sand, 4: stone aggregate of 20 mm nominal size) so that the alignment of RCC pipes remain firm and intact. Also, both ends of RCC pipes spans will be sealed by providing concrete block of size 40 cm (L) x 40 cm (W) x 25 cm (H) of 1:2:4 cement concrete mix to avoid entry of rodents.
- § RCC Split Pipes: The split Reinforced cement concrete pipes (spun type) with in-built collars are used to provide additional protection to PLB HDPE Ducts/coils should be of 100mm internal dia.(Spotted), Class-- NP-3, Thickness: 25mm, Length: 2 Meters with inbuilt collaret one end, Conforming to ISI Specification IS: 458, 1988 with latest amendment
- § G.I. Pipes: G.I. pipes should be of medium duty class having inner diameter of 50 mm and should conform to specifications as per IS 554/1985 (revised up to date) IS 1989 (Part-I), 1900 Sockets (revised up to date) & IS 1239 (Part-II) 1992 (revised up to date).
- § DWC Pipes: Use of normal duty DWC (Double walled corrugated) HDPE pipe – conforming to TEC GR no.GR/DWC-34/01 Sep.2007 with latest amendments shall be preferably utilized as first choice for protection of Optical Fibre Cable instead of GI pipes. The DWC pipes used shall be of size 75/61mm as per table 2 of the said TEC GR.
- § M.S. Weld Mesh: The PLB HDPE Ducts can also be protected by embedding it in concrete of size of 25 cm x25 cm reinforced with MS weld mesh. The MS weld mesh used should be of 50 mm x 100 mm size, 12 SWG, 120 cm in width in rolls of 50 m each. One meter of MS weld mesh caters to approx. 3 meters of concreting. (See figure '2' for details). The strength of RCC/CC is dependent on proper curing, therefore, it is imperative that water content of CC/RCC mix does not drain out into the surrounding soil. In order to ensure this, the RCC/CC work should be carried out by covering all the sides by yellow PVC sheets of weight not less than 1 kg per 8 sq. metre to avoid seepage of water into the soil.
- § Joint Chamber: The Joint chamber shall be provided at every joint location to keep the Optical Fibre Cable joint well protected and also to house extra length of cable which may be required in the event of faults at a later date. The Joint chamber shall be of pre-cast RCC type as per construction specification. Brick chamber can also be made with prior permission of Authority.
- § Rubber Bush: To prevent entry of rodents into PLB HDPE DUCTS, the ends of PLB HDPE DUCTS are sealed at every manhole and joint using rodent resistant hard rubber bush (cap) after Optical Fibre cable is pulled. The rubber bush should be manufactured from hard rubber with grooves and holes to fit into 40 mm PLB HDPE DUCTS pipe, so that it should be able to prevent the entry of insects, rodents, mud, and rainwater into the PLB HDPE DUCTS pipe. It should conform to TEC GR with latest amendments. (See Figure-3).
- § Route/Joint Indicator: The Route/Joint indicators are co-located with each manhole/joint chamber. In addition Route indicators are also to be placed where route changes direction like road crossings etc. Either

RCC/Pre-cast or Stone based route indicators can be used. The detailed specification and design of the same shall be as per construction specification. Generally, Stone Route indicators shall be used.

## **7. Excavation of Trenches**

### **7.1.Trenching**

- ξ Location and Alignment of the Trench: In built up areas, the trench will normally follow the foot-path of the road except where it may have to come to the edge of the carriage way cutting across road with specific permissions from the concerned authorities maintaining the road (such permissions shall be obtained by the department.). Outside the built up limits the trench will normally follow the boundary of the roadside land. However, where the road side land is full of burrow pits or afforestation or when the cable has to cross culverts/ bridges or streams, the trench may come closer to the road edge or in some cases, over the embankment or shoulder of the Road (permissions for such deviations for cutting the embankment as well as shoulder of the road shall be obtained). The alignment of the trench will be decided by a responsible official of the Authority. Once the alignment is marked, no deviation from the alignment is permissible except with the approval of Authority. While marking the alignment only the centre line will be marked and the SI shall set out all other work to ensure that, the excavated trench is as straight as possible. The SI shall provide all necessary assistance and labour, at his own cost for marking the alignment. SI shall remove all bushes, undergrowth, stumps, rocks and other obstacles to facilitate marking the centre line without any extra charges. It is to be ensured that minimum amount of bushes and shrubs shall be removed to clear the way and the SI shall give all, consideration to the preservation of the trees.
- ξ The line-up of the trench must be such that PLB pipe(s) shall be laid in a straight line, both laterally as well as vertically except at locations where it has to necessarily take a bend because of change in the alignment or gradient of the trench, subject to the restrictions mentioned elsewhere.
- ξ Line-Up: The line-up of the trench must be such that PLB HDPE Ducts shall be laid in a straight line except at locations where it has to necessarily take a bend because of change in the alignment or gradient of the trench, subject to the restrictions mentioned elsewhere.

### **7.2.Method of Excavation**

- ξ In built up areas, the SI shall resort to use of manual labour / HDD only to ensure no damage is caused to any underground or surface installations belonging to other public utility services and/or private parties.
- ξ However, along the Highways and cross country there shall be no objection to the SI resorting to mechanical means of excavation, provided that no underground installations existing the path of excavation, if any, are damaged.
- ξ There shall be no objection to resort to horizontal boring to bore a hole of required size and to push through G.I. Pipe (50 mm ID) through horizontal bore at road crossing or rail crossing or small hillocks etc.
- ξ All excavation operations shall include excavation and 'getting out'. 'Getting out' shall include throwing the excavated materials at a distance of at least one meter or half the depth of excavation, whichever is more, clear off the edge of excavation. In all other cases 'getting out' shall include depositing the excavated materials as specified.
- ξ In Rocky strata excavation shall be carried out by use of electro mechanical means like breakers/ jack hammers or by blasting wherever permissible with express permission from the competent authority. If blasting operations are prohibited or not practicable, excavation in hard rock shall be done by chiseling/ jack hammers.
- ξ Trenching shall as far as possible be kept ahead of the laying of pipes. SI shall exercise due care that the soil from trenching intended to be loose for back filling is not mixed with loose debris. While

trenching, the SI should not cause damage to any underground installations belonging to other agencies and any damage caused should be made good at his own cost and expense.

- ξ Necessary barricades, night lamps, warning board and required watchman shall be provided by the SI to prevent any accident to pedestrians or vehicles. While carrying out the blasting operations, the SI shall ensure adequate safety by cautioning the vehicular and other traffic. The SI shall employ sufficient man-power for this with caution boards, flags, sign writings etc.
- ξ The SI should provide sufficient width at the trench at all such places, where it is likely to cave in due to soil conditions without any extra payment. A minimum free clearance of 15 cm should be maintained above or below any existing underground installation. No extra payment will be made towards this. In order to prevent damage to PLB HDPE DUCTS over a period of time, due to the growth of trees, roots, bushes, etc., the SI shall cut them when encountered in the path of alignment of trench without any additional charges.
- ξ In large burrow pits, excavation may be required to be carried out for more than 165 cm in-depth to keep gradient of bed less than 15 degrees with horizontal. If it is not possible as stated above, alignment of trench shall be changed to avoid burrow pit completely.

### 7.3.Depth and Size of the Trench

The depth of the trench from top of the surface shall not be less than 165 cm unless otherwise relaxation is granted by Authority under genuine circumstances. In rocky terrain, less depth shall be allowed only in exceptional circumstances with additional protection where it is not possible to achieve the normal depth due to harsh terrain/ adverse site conditions encountered. This shall be done only with the approval of the Authority. This shall be properly documented. In all cases, the slope of the trench shall not be less than 15 degrees with the horizontal surface. The width of the trench shall normally be 45 cm at the top & 30 cm at the bottom. In case, additional pipes (HDPE/GI/RCC Pipes) are to be laid in some stretches, the same shall be accommodated in this normal size trench. When trenches are excavated in slopes, uneven ground and inclined portion, the lower edge shall be treated as top surface of land and depth of trench will be measured accordingly. In certain locations, such as uneven ground, hilly areas and all other Places, due to any reason whatsoever it can be ordered to excavate beyond standard depth of 165 cm to keep the bed of the trench as smooth as possible. Near the culverts, both ends of the culverts shall be excavated more than 165 cm to keep the gradient less than 15 degree with horizontal. For additional depth in excess of 165 cm, no additional payment shall be applicable.

If excavation is not possible to the minimum depth of 165 cm, as detailed above, full facts shall be brought to the notice of the Authority in writing giving details of location and reason for not being able to excavate that particular portion to the minimum depth. Approval shall be granted by the Authority in writing under genuine circumstances. The decision of the Authority shall be final and binding on the SI. All the relaxations granted as specified above shall be dealt with as per the laid down norms and procedure of Authority.

- Dewatering: The SI shall be responsible for all necessary arrangements to remove or pump out water from trench. The SI should survey the soil conditions encountered in the section and make his own assessment about dewatering arrangement that may be necessary. No extra payment shall be admissible for this.
- Wetting: Wherever the soil is hard due to dry weather conditions, if watering is to be done for wetting the soil to make it loose, the same shall be done by the SI. No extra payment shall be admissible for this.
- Blasting: For excavation in hard rock, where blasting operations are considered necessary, the SI shall obtain approval of the Authority in writing for resorting to blasting operation. The SI shall obtain license from Authority for undertaking blasting work as well as for obtaining and storing the explosive as per the Explosive Act, 1884 as amended up to date and the explosive Rules, 1983. The SI shall purchase the explosives fuses, detonators, etc. only from a licensed dealer. Transportation and storage of explosive at site shall conform to the aforesaid Explosive Act and Explosive Rules. The SI shall be responsible for the safe custody and proper accounting of the explosive materials. Fuses and detonators shall be stored separately and away from the explosives. The Authority or his authorized representative shall have the right to check the SI's store and account of explosives. The SI shall

provide necessary facilities for this. The SI shall be responsible for any damage arising out of accident to workmen, public or property due to storage, transportation and use of explosive during blasting operation. Blasting operations shall be carried out under the supervision of a responsible authorized agent of the SI (referred subsequently as agent only), during specified hours as approved in writing by the Authority. The agent shall be conversant with the rules of blasting. All procedures and safety precautions for the use of explosives drilling and loading of explosives before and after shot firing and disposal of explosives shall be taken by the SI as detailed in IS: 4081 safety code for blasting and related drilling operation.

- Trenching Near Culverts/ Bridges: The PLB HDPE Ducts shall be laid in the bed of culvert at the depth not less than 165 cm protected by RCC pipes as decided by Authority. Both ends of culverts shall be excavated more than 165 cm in depth to keep the gradient of not less than 15 degree with horizontal. The bed of trench should be as smooth as possible.
- While carrying out the work on bridges and culverts, adequate arrangement for cautioning the traffic by way of caution boards during day time and danger lights at night shall be provided. In case of small bridges and culverts, where there is a likelihood of their subsequent expansion and remodelling, the cable should be laid with some curve on both sides of the culvert or the bridge to make some extra length available for readjustment of the cable at the time of reconstruction of culvert or the bridge.

### 8. Laying Of PLB HDPE Ducts

- § After the trench is excavated to the specified depth, the bottom of the trench has to be cleared of all stones or pieces of rock and levelled up properly. A layer of soft soil/or sand (in case the excavated material contains sharp pieces of rock/stones) of not less than 5 cm is required for levelling the trench to ensure that the cable when laid will follow a straight alignment. Adequate care shall be exercised while laying so that the Optical Fibre Cables are not put to undue tension/pressure after being laid as this may adversely affect the optical characteristics of cables with passage of time.
- § The SI shall ensure that trenching and pipe laying activities are continuous, without leaving patches or portions incomplete in between. In case intermediate patches are left, measurement of the completed portions will be taken only after work in such left over patches are also completed in all respects.
- § Preparatory to aligning the pipe for jointing, each length of the PLB HDPE Ducts shall be thoroughly cleaned to remove all sand, dust or any other debris that may clog, disturb or damage the Optical Fibre Cable when it is pulled at a later stage. The ends of each pipe and inside of each Socket shall be thoroughly cleaned of any dirt or other foreign materials.
- § After the trench is cleaned the PLB HDPE Ducts/Coil shall be laid in the cleaned trench, jointed with Sockets. Drawing up of PP rope is optional as per TEC GR. In case of use of PP Rope, at every manhole approximately at every 200 m or at bends or turns the PP rope will be tied to the HDPE end caps used for sealing the PLB HDPE Ducts, to avoid entry of rodents/mud etc.
- § At the end of each day work, the open ends of the pipes sections shall be tightly closed with endcaps to prevent the entry of dirt/mud, water or any foreign matter into PLB HDPE Ducts until the work is resumed. In built up area falling within Municipal/Corporation limits, the PLB HDPE Ducts shall be laid with protection using RCC Pipes/ Concreting reinforced with weld mesh (only in exceptional cases).
- § For lesser depths requiring additional protection in built up areas, towns and cities falling within the municipal limits, suitable protection shall be provided to PLB HDPE pipes/coils using RCC/DWC full round/split pipes or GI pipes or cement concreting reinforced with MS weld mesh or a combination of any of these as per the site requirement. This shall be done only with the prior instructions/approval of the Authority. The specifications for providing each of these protections are given later in this document.
- § Moreover, in cross country routes, if depth is less than 1.2 meters, protection by using RCC/DWC Pipe shall be provided. Authority shall decide about such stretches and type of protection to be provided in view of the site requirements. Normally 100 mm RCC /DWC Pipes shall be used for protecting PLB HDPE Ducts but if more than one PLB pipe is to be laid and protected, RCC/DWC Pipe of suitable size to accommodate the required number of PLB Pipes shall be used.



- § The PLB HDPE Ducts shall be laid in RCC Full Round spun Pipes/GI Pipes as required at Road crossings. The RCC pipes/GI pipes shall extend at least 3 meters on either side of the road at Road crossings. At Road crossings, extra GI/PLB HDPE Ducts may be laid as per the direction of the Authority. On Rail bridges and crossings, the PLB HDPE Ducts shall be encased in suitable cast iron as prescribed by the Railway Authorities.
- § Wherever RCC pipes are used for protection, the gaps between the RCC collars and the RCC pipes shall be sealed using cement mortar 1:3 (1:53 grade cement of reputed brand, 3: fine sand without impurities) to bar entry of rodents. Every third collar of RCC pipes (normally of 2 meters length) and also both ends of RCC Pipes will be embedded in a concrete block of size 40 cm (L)x 40 cm(W) x 25 cm (H) of 1:2:4 cement concrete mix (1:53 grade cement of reputed brand, 2: coarse sand, 3: stone aggregate of nominal size of 20 mm ) so that the alignment of RCC pipes remain firm and intact and to avoid entry of rodents.
- § Wherever GI pipes are used, special care should be taken to ensure that G.I. Pipes are coupled properly with the sockets so as to avoid damage to PLB pipe and eventually the Optical Fibre Cable in the event of pressure coming on the joint and G.I. Pipe joint giving its way. Rubber bushes shall be used at either ends of the GI pipes to protect PLB pipe. Both the ends of G.I. Pipe will be embedded in a concrete block of size 40 cm (L) x 40 cm ((W) x 25 cm (H) of 1:2:4 cement concrete mix (1:53 grade cement of reputed brand, 2: coarse sand, 3: stone aggregate of nominal size of 20 mm) so that the alignment of G.I. Pipes remain firm and intact and to avoid entry of rodents.
- § In case of protection by concreting at site, the nominal dimension of concreting shall be 250 mm x250 mm section. Cement Concrete Mixture used shall be of 1:2:4 composition i.e. 1:53 grade Cement of a reputed company, 2: Coarse Sand, 4: Graded Coarse Stone aggregate of 20 mm nominal size, reinforced with MS weld mesh. As the RCC is cast at site, it is imperative to ensure that special care is taken to see that proper curing arrangements are made with adequate supply of water. The SI shall invariably use mechanical mixer at site for providing RCC protection, to ensure consistency of the mix.
- § For carrying out concreting work in trenches, yellow PVC sheets of width not less than 1.0 M and of weight not less than 1 kg. Per 8 sq. meters shall be spread and nailed on sides of the trench to form trapezoidal section for concreting in the cleaned trench, to avoid seepage of water into the soil.
- § A bed of cement concrete mixture of appropriate width and 75 mm thickness shall be laid on the PVC sheet, before laying PLB HDPE ducts. The PLB HDPE Ducts shall then be laid above this bed of concrete. After laying the PLB HDPE Ducts, MS weld mesh is wrapped around and tied and concrete mix is poured to form the cross sectional dimensions as instructed by the Authority.
- § The strength of RCC is dependent on proper curing therefore, it is imperative that water content of RCC mix does not drain out into the surrounding soil. Portions where cement concreting has been carried out shall be cured with sufficient amount of water for reasonable time to harden the surface. After curing, refilling of the balance depth of the trench has to be carried out with excavated soil.
- § The PLB HDPE Ducts/RCC/GI Pipes shall be laid only in trenches accepted by Authority or his representative. The SI shall exercise due care to ensure that the PLB HDPE Ducts are not subjected to any damage or strain.
- § Water present in the trench at the time of laying the PLB HDPE Ducts shall be pumped out by the SI before laying the pipes in the trench to ensure that no mud or water gets into the pipes, thus choking it.
- § In case of nallahs, which are dry for nine months in a year, the PLB HDPE Ducts shall be laid inside the RCC Pipes laid at a minimum depth of 165 cm, as instructed by the Authority. The mechanical protection shall extend at least 5 meters beyond the bed of nallah on either side.
- § Notwithstanding anything contained in clauses referred above, the Authority may order, based on special site requirements, that the PLB HDPE Ducts may be encased in reinforced cement concrete, as detailed, in bid. While laying the pipes, a gap of 2 M is kept at convenient locations approx. 200 m apart and at the bends and turns, which will be used as manholes during Optical Fibre cable pulling. Ends of the PLB HDPE Ducts at the manholes shall be sealed using end caps after tying the PP rope to the end caps to avoid choking of the pipes. In a similar manner, manholes shall be kept while approaching bridges, road crossings etc., as instructed by the Authority. The location of the manholes will be decided by the Authority.

### **8.1. Laying Protection Pipes on Bridges and Culverts:**

- § In case trenching and pipe laying is not possible on the culverts, the pipes shall be laid on the surface of the culverts/bridges after due permission from the Authority. Of late the bridge construction authorities are providing channel ducts on the footpaths on the bridges for various services. The RCC/DWC/ G.I. Pipes can be laid in these ducts for pulling cables. However, for laying cables on existing bridges, where duct arrangement does not exist, one of the following methods may be adopted.
- § In case of the Bridges/Culverts, where there are no ducts and where the cushion on the top of the Arch is 50 cm to 100 cm or more, G.I. Pipe (Carrying PLB HDPE pipe and cable) may be buried on the top of the Arch adjoining the parapet wall, by digging close to the wheel guards. Every precaution shall be taken to see that no damage occurs to the arch of the culvert. After burying the GI pipe, the excavated surface on the arch shall be restored.
- § Where the thickness of the Arch is less than 50 cm, the pipe must be buried under the wheel guard masonry and the wheel guard rebuilt.
- § If neither of the two methods is possible, the G.I. Pipes/GI Troughs must be clamped on the parapet wall with the clamps. If necessary, the pipes may be taken through the parapet wall at the ends where the wall diverges away from the road.
- § Methods cited in above clauses should be carried out under close supervision of Road authorities. The surface to be concreted should be thoroughly cleaned and levelled before concreting. At both ends of the Bridges/Culverts, where the GI Pipes /GI Troughs slope down and get buried, the concreting should be extended sufficiently to ensure that no portion of the GI Pipes/GI Troughs is exposed as approved by the Authority to protect the pipe/trough from any possible externally caused damage.
- § Where white wash/colour wash is existing on the Bridges/ Culverts, the same should also be carried out on the concreted portion to ensure uniformity.

### **9. Back Filling and Dressing of the Trench**

- § Provided that the PLB HDPE pipes have been properly laid in the trench at the specified depth, the back filling operation shall follow as early as practicable. The earth used for filling shall be free from all roots, Grass, shrubs, vegetation, trees, saplings and any other kind of garbage or pebbles. The back filling operation shall be performed in such a manner so as to provide firm support under and above the pipes and to avoid bend or deformation of the PLB HDPE pipes when the pipes get loaded with the back filled earth.
- § At locations where the back filled materials contains stones/sharp objects which may cause injury to the PLB HDPE pipes and where the excavated or rock fragments are intended to refill the trench in whole or in part, the trench should be initially filled, with a layer of ordinary soil or loose earth (free from any stones/pebbles) not less than 10 cm thick over the pipes.
- § Back filling on public, roads, railway crossings, footpaths in city areas shall be performed immediately after laying the HDPE pipes. Back filling at such locations shall be thoroughly rammed, so as to ensure original condition so that it is safe for the road traffic. All excess soil/ material left on road/ footpath/railway crossing shall be removed by SI. However, along the highways and in country side, the excess dug up material left over after refilling should be kept in a heap above over the trench.
- § In city limits, at any given time not more than 50 Meters length of trench should be kept open and in all places where excavation has been done, no part of the trench should be kept open over night to avoid occurrence of any mishap or accident in darkness.

### **10. Restoration of Road Surface**

Road restoration work to be made with bituminous macadam for semi grouting 50 mm thick and premix carpet surfacing 25 mm thick over the grouted surface (total up to 75 mm thick) including supply of asphalt etc. to evenly match the road, including consolidation and rolling as per standard specification of DSR 1997. Road restoration work with cement concrete 1:4:8 mix for thickness varying from 150 mm to 225 mm, including supply of concrete to be made to evenly match the road.

## 11.Cable Pulling and Joining/Splicing

### 11.1.Cable Pulling

- § Manholes marked during PLB HDPE Ducts pipe laying of approx. size of 2.0 m length x 1.0 m width x 1.65 m depth shall be excavated for pulling the cables. There may be situations where addition manholes are required to be excavated, for some reasons, to facilitate smooth pulling of cable. Excavation of addition manholes will be carried out, without any extra cost. De-watering of the manhole, if required, will be carried out without any extra costs. Dewatering/ De-gasification of the Ducts, if required, will be carried out without any extra costs.
- § The Optical Fibre Cables are available in drums in lengths of approx. 2 km. The cables shall be blown / manually pulled (in exceptional cases) through already laid PLB HDPE DUCTS. This work is to be carried out under the strict supervision of site in-charge. It shall be ensured that during the blowing / pulling of Cable the tension is minimum and there is no damage to the Cable/Optical Fibres.
- § After pulling of the drum is completed, both ends of the PLB HDPE DUCTS pipe in each Manhole should be sealed by hard rodent resistant rubber bush, to avoid entry of rodents/mud into PLBHDPE Ducts.
- § The Manholes are prepared by providing 40 mm split PLB HDPE DUCTS pipe of 2.5 to 3m length and closing the split PLB HDPE Ducts by providing necessary clamps/ adhesive tape as per the directions of Authority. Afterwards, the split/cut PLB HDPE DUCTS pipe are covered with 100 mm split RCC pipe of 2m length and sealing the ends of RCC pipe with lean cement solution for protecting bare cable in the manhole . After fixing of RCC Split Pipes necessary back filling/reinstatement and dressing of manholes should be carried out as referred under trenching. The location of the pulling manhole should be recorded for preparation of documentation.

### 11.2.Jointing/ Splicing

The required fibres are to be spliced at every Joint & at both ends (Terminations) in the equipment room as directed by Authority. The Infrastructure required for cable splicing i.e. Splicing machine, OTDR, Optical talk set, Tool kit, etc. will be arranged by the SI and also any additional accessories. e. g. Engine etc. required at site for splicing will also be arranged by the SI.

The Optical Fibre Cable thus jointed end-to-end will be tested by the Authority/ Acceptance Testing unit of the concerned Authority for splice losses and transmission parameters as specified by Authority and prevalent at that time. The through Optical Fibre should meet all the technical parameters, specified and no relaxation will be granted.

### 11.3.Splicing of Fibres

- § Wash hands thoroughly prior to connecting this procedure.
- § Place the bare fibre inside 'V' groove of the splicing machine by opening clamp handle such that the end of fibre is app.1 mm. over the end of the 'V' groove towards the electrodes.
- § Repeat the same procedure for other fibre; however first insert heat shrink splice protector.
- § Press the start button on the splice controller.
- § The machine will pre fuse, set align both in 'X' and 'Y' direction and then finally fuse the fibre.
- § Inspect the splice on monitor if provided on the fusion splicing machine and assure no nicking, bulging is there and cores appear to be adequately aligned if the splice does not visually look good repeat the above procedure.
- § Slide the heat shrink protector over the splice and place in tube heater. Heat is complete when soft inner layer is seen to be 'oozing' out of the ends of the outer layer of the protector.



- ξ Repeat the same procedure for all the other fibres.

### **11.4 Organizing Fibre and Finishing Joint**

- ξ After each fibre is spliced, the heat shrink protection sleeve must be slipped over the bare fibre before any handling of fibre takes place, as uncoated fibres are very brittle and cannot withstand small radius bends without breaking.
- ξ The fibre is then organized into its tray by coiling the fibres on each side of the protection sleeve using the full tray side to ensure the maximum radius possible for fibre coils.
- ξ The tray is placed in the position.
- ξ OTDR reading taken for all splices in this organized state and recorded on the test sheet to confirm that all fibres attenuation are within 0.1 db per splice. This OTDR test will confirm fibres were not subjected to excessive stress during the organizing process.
- ξ After this the joint can be closed with necessary sealing etc. and ready for placement in the pit

### **11.5 Placing of Completed Joint in Pit**

- ξ Joint is taken out from the vehicle and placed on the tarpaulin provided near the pit.
- ξ The cable is laid on the ground, loop the cable such that pen mark previously placed on the cable line up. Tape these loops together at the top of the coil.
- ξ The joint can now be permanently closed and sealed mechanically. However, before closing, silica gels to be kept inside for moisture protection.
- ξ Now the joint closure is fixed to the bracket on the pit wall and pit is closed.

## **12. Construction of Jointing Chamber**

The joint chambers are provided at every joint to keep the Optical Fibre Cable joint well protected and also to keep extra length of cable, which may be, required to attend the faults at a later date. Jointing chambers are to be prepared normally at distance of every 2 km. Actual location of jointing chamber depends on length of cable drum and appropriateness of location for carrying out jointing work. The location is finalized by Authority. The jointing chambers are constructed by way of fixing pre-cast RCC chambers/Brick Chambers and covers as per the instructions from Authority.

### **12.1 Pre cast RCC chamber**

For fixing pre cast RCC chamber, first a pit of size 2 m x 2 m x 1.8 m depth shall be required to be dug. Pre cast RCC chamber shall consist of three parts (i) round base plate of 140 cm diameter and 5 cm thickness in two halves (ii) full round RCC joint chamber with diameter of 120 cm and height of 100 cm and thickness of 5 cm (iii) round top cover will be in two halves with diameter of 140 cm and thickness of 5 cm having one handle for each half in centre and word 'CG OFC' engraved on it. (See figure '4'). After, fixing the pre cast RCC joint chamber, the joint chamber is filled with clean sand before closing. Back filling of joint chamber pit with excavated soil shall be carried out in the end.

### **12.2 Brick Chamber**

For constructing brick chamber, first a pit of size 2m x 2 mx 1.8 m depth is shall be required to be dug, then, base of the chamber shall be made using concrete mix of 1:5:10 (1 cement, 5 coarse sand, 10 graded stone aggregate of 40mm nominal size) of size of 1.7m x 1.7 m and 0.15 m thickness. Wall of brick chamber should be constructed on this base having wall thickness of 9" using cement mortar mix of 1:5 (1: cement, 5: fine sand). The chamber should have internal dimensions of 1.2 m x 1.2 m and 1 m height. The bricks to be used for this purpose should be of size 9" x 4.5" x 3", best quality available and should have smooth rectangular shape with sharp corners and shall be uniform in colour and emit clear ringing sound when struck.

The joint chamber should be so constructed that PLB pipe ends remain protruding minimum 5 cm inside the chamber on completion of plastering. The PLB pipes should be embedded in wall in such a way that, the bottom brick should support the pipe and upper brick should be provided in a manner that PLB HDPE pipe remains free from the weight of the construction. The joint chamber should be plastered on all internal surfaces and top edges with cement mortar of 1:3 (1: cement, 3: coarse sand), 12 mm thick finished with a floating coat of complete cement as per standard. Pre-cast RCC slab with two handles to facilitate easy lifting, of size 0.7 m x 1.4 m and of thickness of 5 cm having one handle for each half in centre and word 'OFC' engraved on it are to be used to cover the joint chamber. Two numbers of such slabs are required for one joint chamber. This pre-cast slab should be made of cement concrete mix of 1:2:4 (1: cement, 2: coarse sand, 4: stone aggregate 6 mm nominal size) reinforced with steel wire fabric 75 x 25 mm mesh of weight not less than 7.75 Kg per sq. Meter. The joint chamber is filled with clean sand before closing. Back filling of joint chamber pit with excavated soil shall be carried out in the end

### 13. Fixing of Route Indicators / Joint Indicators

Pits shall be dug around every 250 m towards jungle side at every Manhole and Jointing chamber for fixing of Route/Joint Indicator. In addition, Route Indicators are also required to be placed where Optical Fibre Cable changes directions like road crossing etc. The pits for fixing the indicator shall be dug for a size of 60 cm x 60 cm and 75 cm (depth).

The indicator shall be secured in upright position by ramming with stone and murrum up to a depth of 60 cm and concreting in the ratio of 1:2:4 (1: cement, 2: coarse sand, 4 stone aggregate 20 mm nominal size) for the remaining portion of 15 cm. Necessary curing shall be carried out for the concreted structure with sufficient amount of water for reasonable time to harden the structure.

#### 13.1 RCC/Pre cast Route Indicators

The route /joint indicator made of pre-cast RCC should have the following dimensions:  
Base - 250 mm x 150 mm Top - 200 mm x 75 mm Height - 1250 mm (See Figure '5')

#### 13.2 Stone based Route Indicators

The route /joint indicators made of Sand/lime Stone Should have the following dimension. The word 'CG OFC' should be engraved on the Route/Joint indicators.

- i. Stone to be used (Sand/lime Stone)
- ii. Indicator Top surface to be rounded
- iii. Base 155 mm × 100 mm
- iv. Upper 500 mm length to be Tapered width wise as shown in the drawing and homogeneously finished.
- v. Height 650mm (Straight) + 400 mm (Tapered)
- vi. The route indicators should be engraved with word 'OFC' of size 80mm length & 50mm, width.
- vii. Length 3.5 Ft., top 4"x4" dressed 1Ft. from top & tapered.

(See figure for details of Stone Route Indicators)

The Route indicators shall painted Blue and placed at 500 to 1000 cm away from the centre of the trench towards jungle side. The Joint indicators are placed at OFC joints and placed 500 to 1000 cm away from wall of the joint chamber facing jungle side and are painted Grey. The engraved word "CG OFC" should be painted in white, on route as well as joint indicators. Numbering of route indicators/joint indicators should also be done in white paint. The numbering scheme for route indicators will be Joint No. /Route Indicator No. for that joint. For example, 2/6 marking on a route indicator means 6th route indicator after 2nd joint. Additional joints on account of faults at a later date should be given number of preceding joint with suffix A, B, C, and D. For example sign writing 2A on a joint indicator means, additional joint between joint No. 2 and 3. The numbering of existing route/joint indicator should not be disturbed on account of additional joints. Enamel paints of reputed brand should be used for painting and sign writing of route as well joint indicators.

## Volume- II

The route and joint indicator shall be painted with primer before painting with oil paint. The material used should bear ISI mark. The size of each written letter should be at least 3.5 cm. The colours of painting and sign writing is as under:

- i. For Joint Indicator: Grey color
- ii. For Route Indicator: Blue color
- iii. For Authority OFC & Nos: White color

### **Penalty for Deviation from Standard Engineering Instructions**

#### **Underground Laying**

Normally depth of the trench should 1.65 m in normal & mix soil and 1.2m in hard soil. Deviations due to field conditions will be required to have necessary protections in case of less depth. The cases and solutions are as following;

- Minimum depth of burial in general shall be 1.65m
- In rocky area (including Murrum & soil mixed with stone or soft rock) depth of burial shall be 1.2m at the minimum.
- In case of utility where depth is 90 to 120 cm then DWC protection is to be used in normal/mix soil case.
- In some areas where the depth is 60cm, in those cases reinforced concrete casing of 4"(Four inch) round should be provided.
- For hard strata/rock soil layer for 60 to 90 cm cases DWC with wire mess and PCC is to be used. However, for depth relaxation photograph (with GPS) proof and justification is required.

Above ground installation of ducts shall be limited to culvert and bridge crossings only. At such locations, ducts shall be installed inside GI pipe or HDPE DWC pipes with metal sheet protection (GI sheet wrapping) of appropriate size (4" to 6") suitable for number of ducts to be installed

The relaxation by the competent authority prescribed below shall be obtained giving reasons for not achieving standard depth;

Size/Type of Cable	Standard Depth cms.	Minimum acceptable Depth without Relaxation	Powers delegated for Relaxation, For depth upto	
			Designated Authority appointed Off -1	Designated Authority appointed Officer -2
OFC	165	90%	80%	30% As per latest EI and latest instructions with protection

*Table 112: Relaxation on excavation standards*

In case, SI does not adhere to the mentioned Engineering Instructions and does not provide requisite protection, then the SI is liable to penalty as per below;

Depth between	Reduction in rates	Rate Payable
<165cm. to $\geq$ 150cm.	5% of approved rates	95% of the approved rates for the achieved depth
<150cm. to $\geq$ 130cm.	12.5% of approved rates	87.5% of the approved rates for the achieved depth
<130cm. to $\geq$ 100cm.	25% of approved rates	75% of the approved rates for the achieved depth

**Volume- II**

Depth between	Reduction in rates	Rate Payable
<100 cm.	40% of approved rates	60% of the approved rates for the achieved depth

*Table 113: Penalty for deviation from excavation standards*

**Note:** In case of depth below 1.2m, instructions as per latest EI and instructions for protection etc. will be followed.

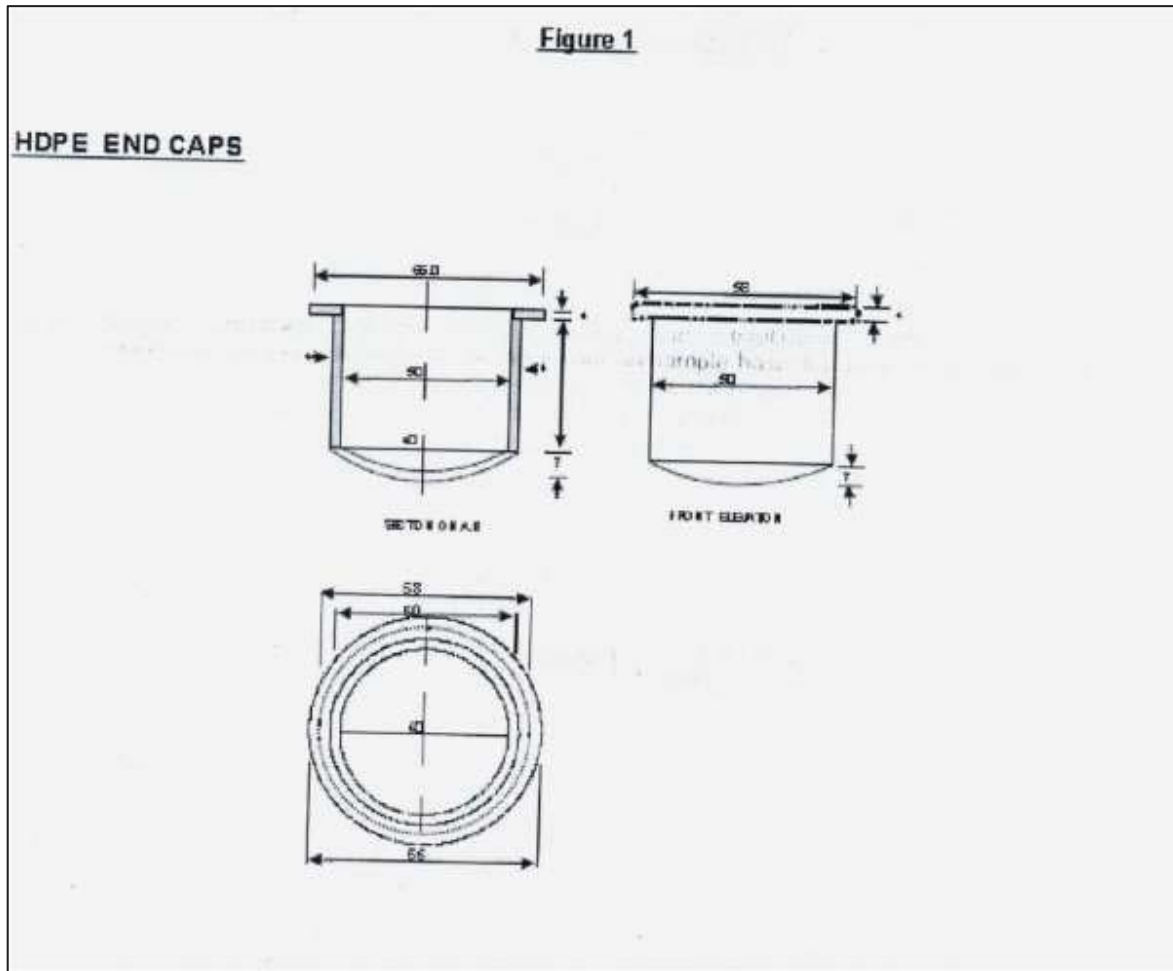
Assuming that the standard depth required is 165 cm and the rate approved is Rs.100/- for the standard depth, then as per the above formula, for a depth of 100 cm the rate worked out is

Rate Applicable =  $100 \times 0.75 = \text{Rs.}75/-$  per running meter

Actual amount to be paid =  $(100/165) \times 75 = \text{Rs.}45.455/- = \text{Rs.}45.5/-$  per running meter

**FIGURES**

1. **End Cap**

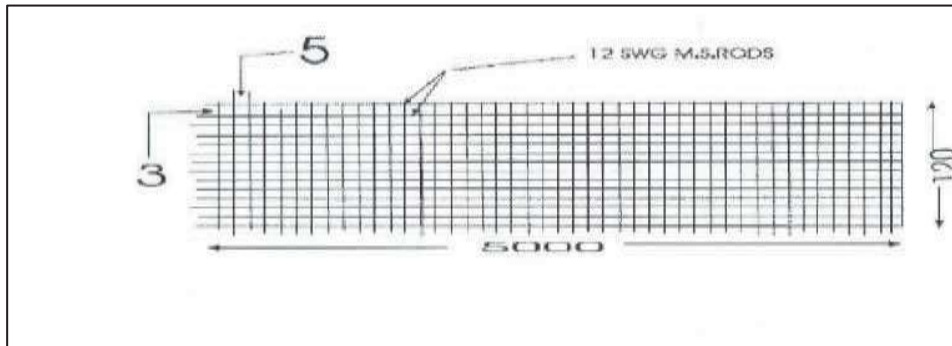


*Figure 4: HDPE End Caps*

**M.S. WELDMESH**

DETAILS OF 100 MM X 50 MM, 12 SWG MILD STEEL WELD MESH HAVING WIDTH OF 120 CM.

## Volume- II



### Note:

- All Dimensions are in mm
- Dimensions are only for guidance.
- Tapper should be such that it should be tightly fixed into Type A & Type B HOPE 50 mm OO pipes

### Rubber Cork

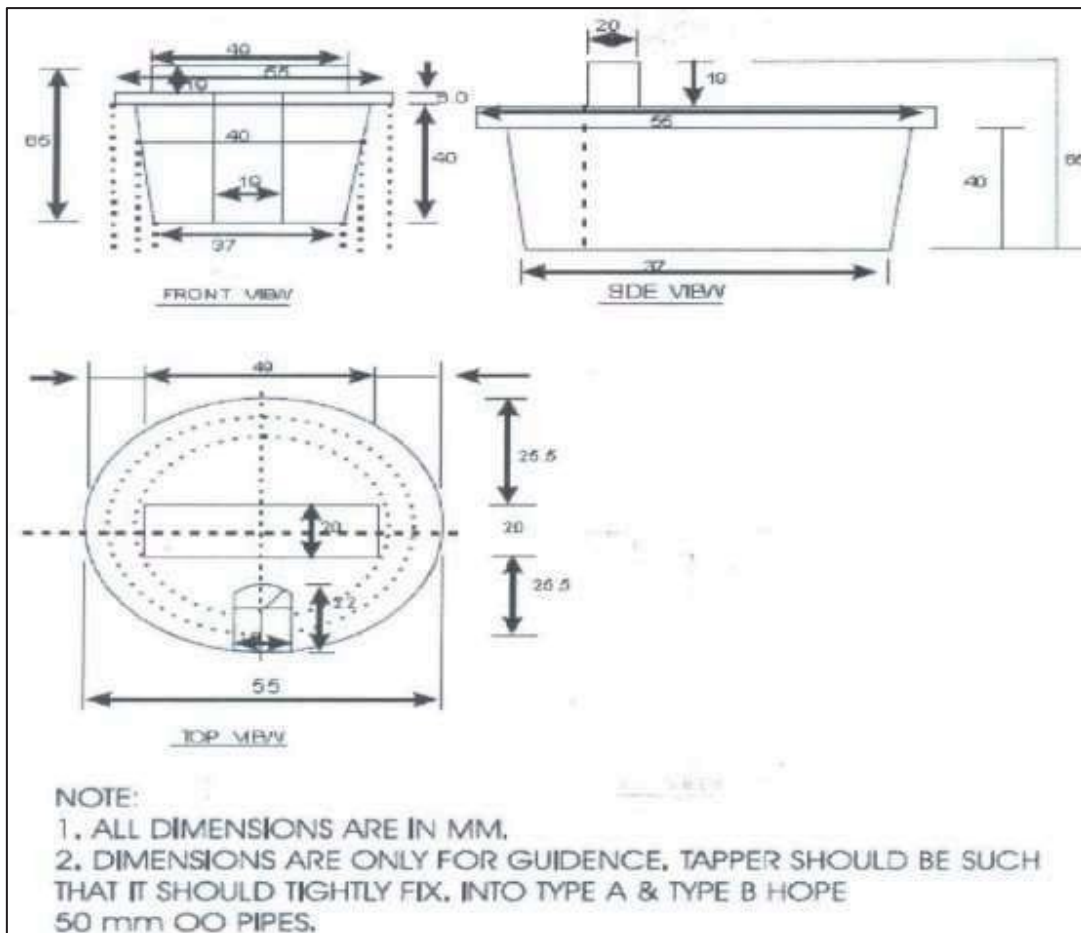


Figure 5: Rubber Cork

### Reinforcement Details

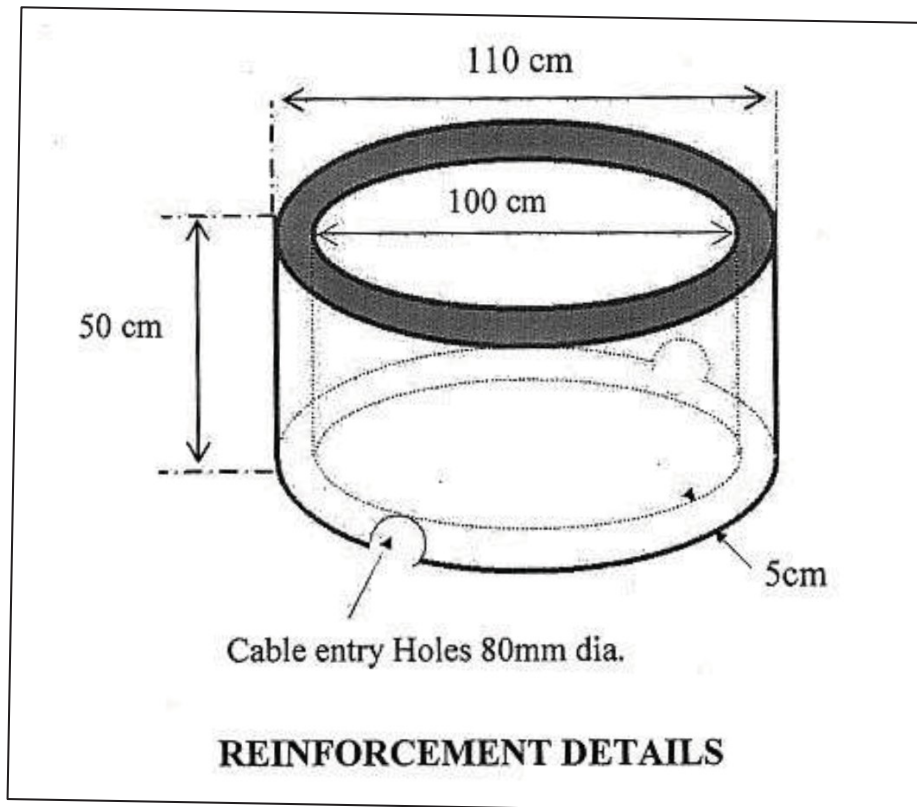
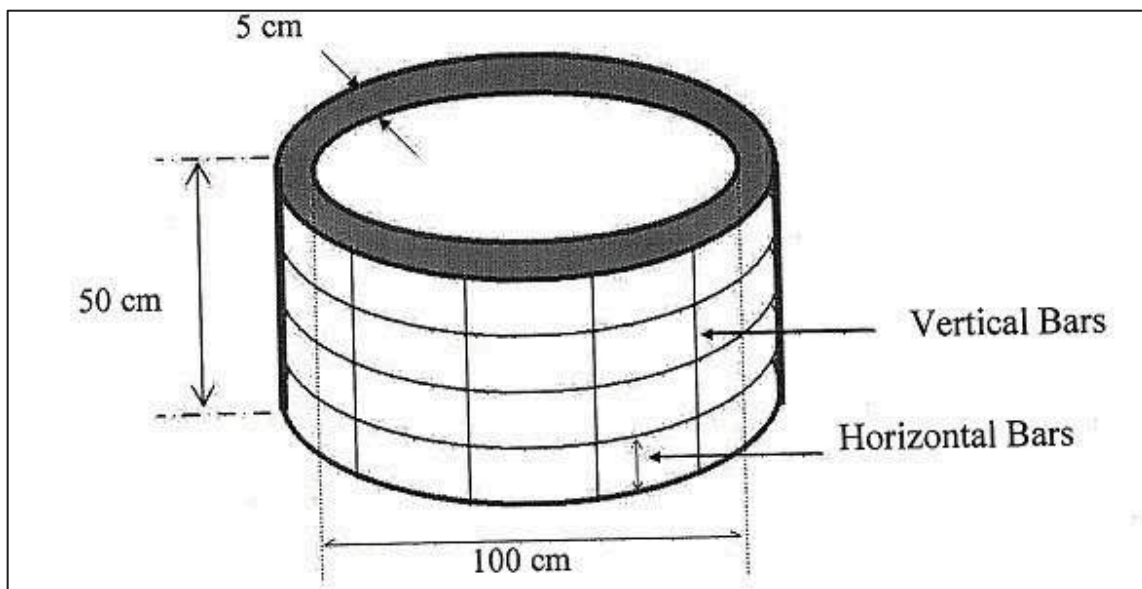


Figure 6: TECHNICAL SPECIFICATION AND REINFORCEMENT DETAILS OF PRECAST RCC CHAMBER - RINGS / COLLAR



Specifications

## Volume- II

---

- 1) Inner Diameter : 100 cm
- 2) Outer Diameter : 110 cm
- 3) Height : 50 cm
- 4) Thickness : 5 cm
- 5) Two number of 80 mm diameter semi-circular holes for cable entry diametrically opposite to each other at bottom end of the collar.
- 6) RCC Rings shall be NP-2 Class. The ring may be supplied either as two rings of 25 cm each or as one ring of 50 cm. One single ring shall be preferred.

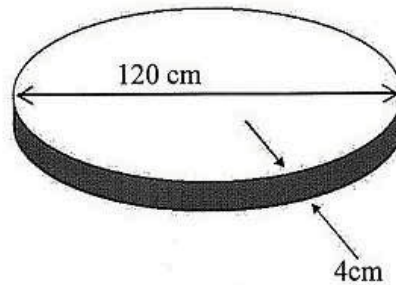
### Reinforcement Details

- 1) 6 mm Horizontal Iron round rings – 4 Nos.
- 2) 6 mm Vertical bars – 12 mm Nos.
- 3) 12 gauge GI wire mesh to be wrapped before reinforcing the concrete.
- 4) Concrete Mix: 1:2:3 (1 cement : 2 sand : 3 graded stone aggregate 20 mm nominal size)
- 5) Finishing: Smooth

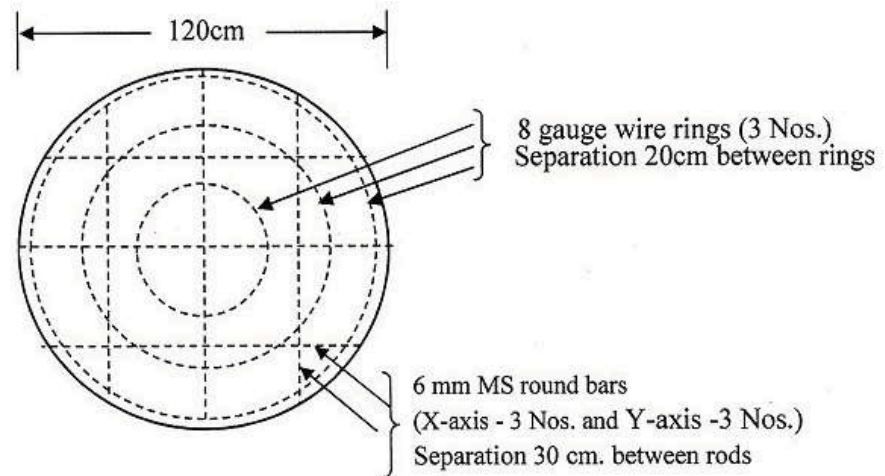


Figure-4.2

**TECHNICAL SPECIFICATION AND REINFORCEMENT DETAILS**  
**PRECAST RCC CHAMBER-ROUND BASE PLATE**



**REINFORCEMENT DETAILS**



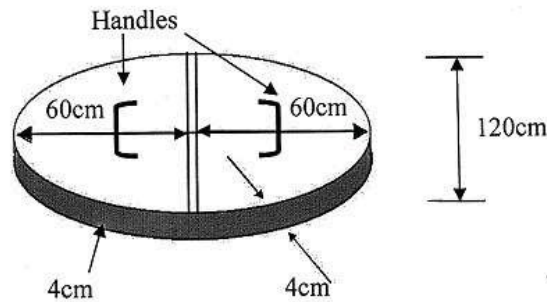
**Specifications and Reinforcement Details**

1. 120 cm outer diameter circular plate with 4 cm thickness.
2. 8 gauge wire rings -3 Nos. at equidistance.
3. The separation of 6mm MS round rings shall be about 20cm between the rings.
4. 6 mm MS round bars on X axis - 3Nos and on Y axis - 3Nos.
5. 6 mm MS round bars separation shall be about 30 cm.
6. Concrete Mix – 1:2:3 ( 1 cement : 2 sand : 3 graded stone aggregate 20 mm nominal size)
7. Finishing; smooth.
8. The base plate can be supplied in two halves also. However in such cases 6 mm MS round bars shall be 3 Nos. on X axis and 2 Nos. on Y axis.

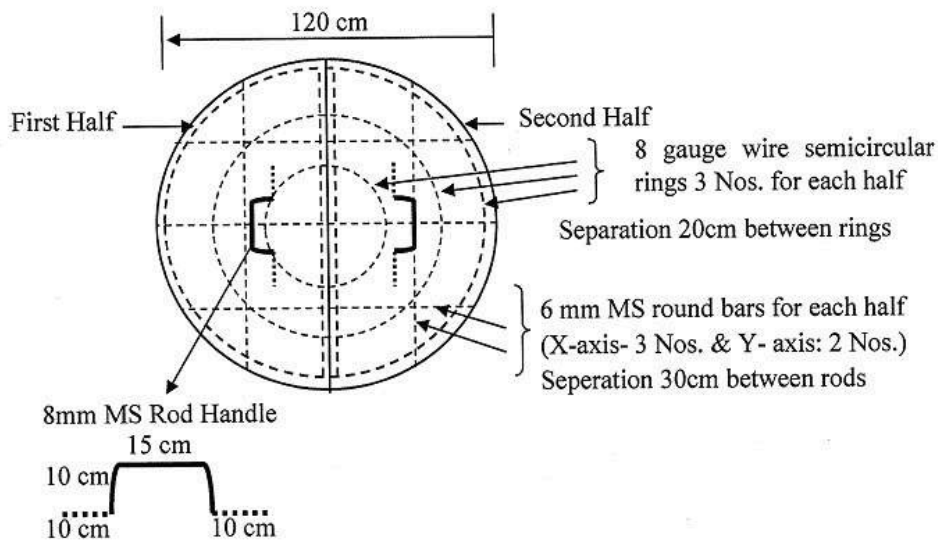


Figure-4.3

**TECHNICAL SPECIFICATION AND REINFORCEMENT DETAILS OF  
PRECAST RCC CHAMBER-ROUND TOP COVER**



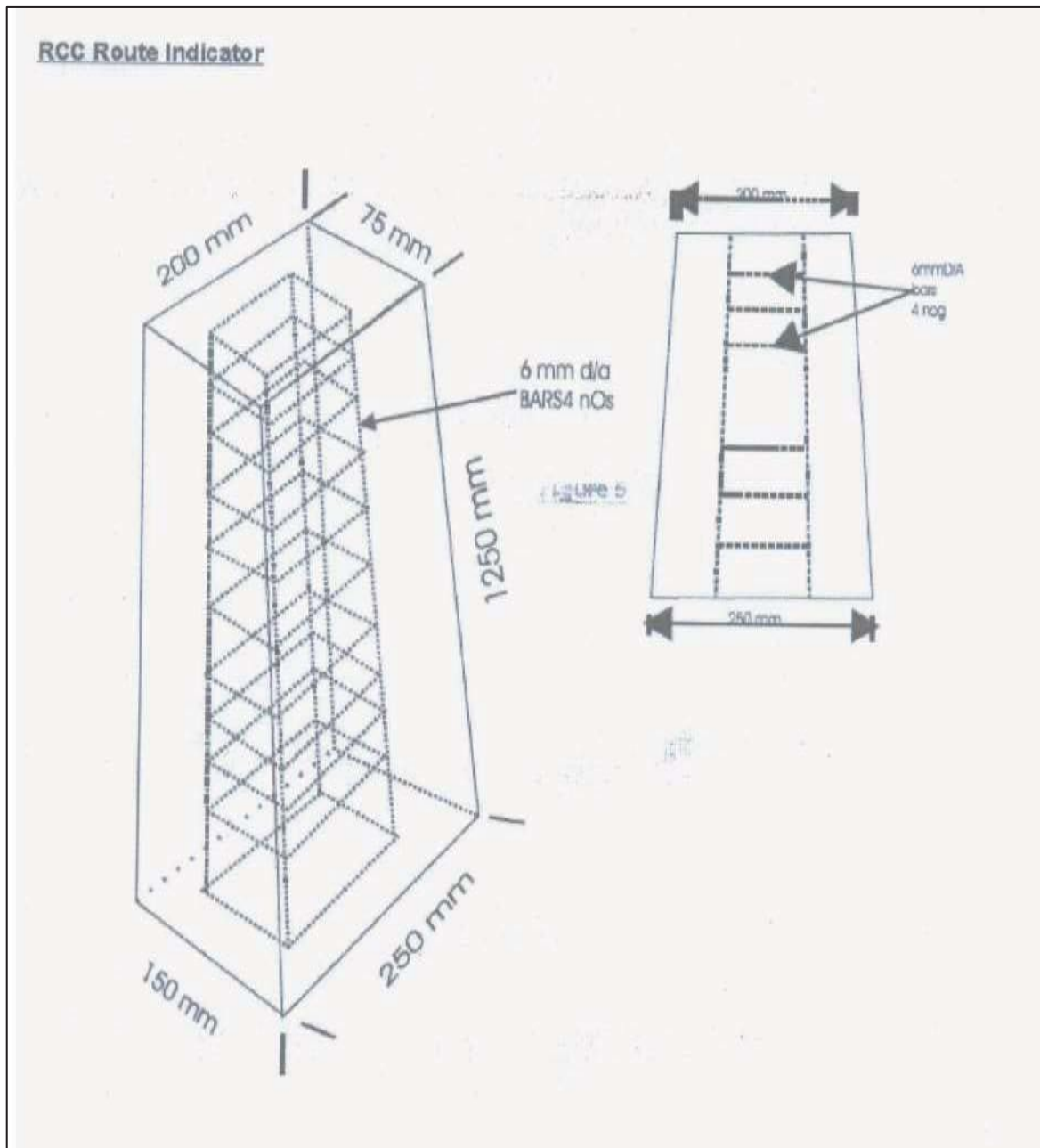
**REINFORCEMENT DETAILS**

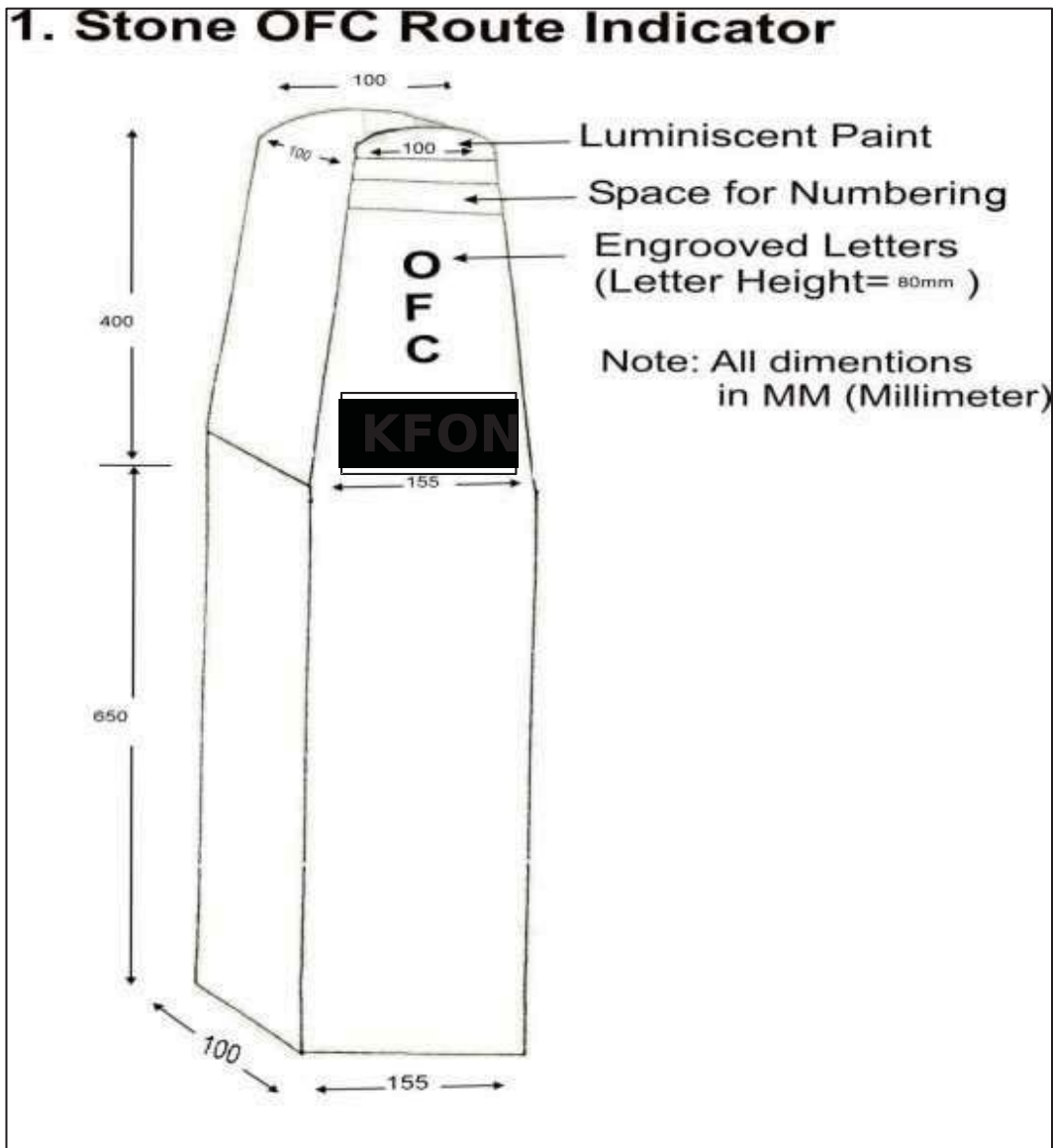


**Specifications and Reinforcement Details**

1. Two numbers of semicircular plates of 120 cm diameter (60 cm radius)
2. 8 gauge wire semicircular rings 3 Nos. for each half. Separation between the rings shall 20 cm.
3. 6 mm MS round bars X-axis: 3 Nos. and Y- axis: 2 Nos. for each half. Separation between the bars shall be 30 cm.
4. One handle shall be provided for each half in centre for handling and for smooth opening of joint Chamber. The hooks size shall be of size 15 cm x 10cm of 8 mm MS rod and properly secured with the reinforcement.
5. The word "BNL OFC" shall be engraved on each half.
6. Concrete Mix : 1:2:3 ( 1 cement : 2 sand : 3 graded stone aggregate 20mm nominal size)
7. Finishing : smooth

**RCC Route Indicator**





## Annexure III - General Guidelines Regarding Execution of V

### SAFETY PRECAUTIONS

#### 1. Safety Precautions when excavating or working in excavations close to electric cables

The Authority of the work will assist SI to get full information from KSEBL regarding any electric cables, which are known or suspected to exist near the proposed excavation and unless this is done, excavation should not be carried out in the section concerned. The work should be preceded with close consultation with them.

Only wooden handled hand tools should be used until the electric cables have been completely exposed. Power Cables, not laid in conduits, are usually protected from above by a cover slab of concrete, brick or stone. They may or may not be protected on the sides. It is safer, therefore, always to drive the point of the pick axe downwards then uncovering a cable, so that there is less chance of missing such warning slabs. No workman should be permitted to work alone where there are electric cables involved. At least one more man should be working nearby so that help can be given quickly in case of an accident. If disconnection of power could be arranged in that section it will be better. No electric cables shall be moved or altered without the consent of the KSEBL and they should be contacted to do the needful. If an electric cable is damaged even slightly, it should be reported to the KSEBL and any warning bricks disturbed during excavation should be replaced while back filling the trench. Before driving a spike into the ground, the presence of other underground properties should be checked. Information on plans regarding the location of power cables need not to be assumed as wholly accurate. Full precautions should be taken in the vicinity until the power cable is uncovered. All electric cables should be regarded as being live and consequently dangerous. Any power is generally dangerous, even low voltage proving fatal in several cases.

#### 2. Electric shock-Action and treatment

Free the victim from the contact as quickly as possible. He should be jerked away from the live conductors by dry timber, dry rope or dry clothing. Care should be taken not to touch with bare hands as his body may be energized while in contact. Artificial respiration should begin immediately to restore breathing even if life appears to be extinct. Every moment of delay is serious, so, in the meanwhile, a doctor should be called for.

#### 3. Safety Precautions while working in public street and along railway lines

Where a road or footpath is to be opened up in the course of work, special care should be taken to see that proper protection is provided to prevent any accidents from occurring. Excavation work should be done in such a manner that it will not unduly cause inconvenience to pedestrians or occupants of buildings or obstruct road traffic. Suitable bridges over open trenches should be so planned that these are required for the minimum possible time. Where bridges are constructed to accommodate vehicular traffic and is done near or on railway property, it should be with the full consent and knowledge of the competent railway authorities.

#### 4. Danger from falling material

Care should be taken to see that apparatus, tools or other excavating implements or excavated materials are not left in a dangerous or insecure position so as to fall or be knocked into the trench thereby injuring any workman who may be working inside the trench.

#### 5. Care when working in Excavations

Jumping into a trench is dangerous. If it is deep, workmen should be encouraged to lower themselves. Workers should work at safe distance so as to avoid striking each other accidentally with tools. If the walls of the trench contain glass bits, corroded wire or sharp objects they should be removed carefully. If an

obstruction is encountered, it should be carefully uncovered and protected if necessary. If an obstruction is encountered, it should be carefully uncovered and protected if necessary. Care must be taken to see that excavated material is not left in such a position that it is likely to cause any accident or obstruction to a roadway or waterway. If possible the excavated material should be put between the workmen and the traffic without encroaching too much on the road.

### **6. Danger of cave in**

When working in deep trenches in loose soil, timbering up/shoring the sides will prevent soil subsidence. The excavated material should be kept at sufficient distance from the edge of the trencher pit. Vehicles or heavy equipment must not be permitted to approach too close to the excavation.

When making tunnelled opening, it should be ensured that the soil is compact enough to prevent cave in even under adverse conditions of traffic. Extra care should be taken while excavating near the foundations of buildings or retaining walls. In such cases, excavation should be done gradually and as far as possible in the presence of the owners of the property.

### **7. Protection of Excavations**

Excavations in populated areas, which are not likely to be filled up on the same day should be protected by barriers or other effective means of preventing accidents and the location of all such openings must in any event be indicated by red flags or other suitable warning signs. During the hours from dusk to dawn, adequate number of red warning lamps should be displayed. Supervisory officers should ensure that all excavations are adequately protected in this manner as serious risk and responsibility is involved. Notwithstanding adoption of the above mentioned precautions, works involving excavations should be so arranged as to keep the extent of opened ground and the time to open it to a minimum.

### **8. Precautions while working on roads**

The period between half an hour after sun-set and half an hour before sunrise, and any period of fog or abnormal darkness may also be considered as night for the purpose of these instructions, for the purpose of providing the warning signs.

Excavation liable to cause danger to vehicles or the public must at all times be protected with fencing of rope tied to strong uprights or bamboo poles at suitable height or by some other effective means. Any such temporary erection which is likely to cause obstructions and which is not readily visible should be marked by posts carrying red flags or boards with a red background by day and by continuously lighted lamps at night.

The flags and the lamps should be placed in conspicuous positions so as to indicate the pedestrians and drivers of vehicles the full expanse i.e. both width and length of the obstruction. The distance between lamps or between floors should not generally exceed 1.25 m along the width and 6m along length of the obstruction in non-congested areas, but 4 meters along the length in congested areas.

If the excavation is extensive, sufficient notice to give adequate warning of the danger, should be displayed conspicuously not less than 1.25 m above the ground and close to the excavation. Where any excavation is not clearly visible for a distance of 25m to traffic approaching from any direction or any part of the carriage way of the road in which the excavation exists, a warning notice should be placed on the kerb or edge of all such roads from which the excavation or as near the distance as is practicable but not less than 10 m from the junction of an entering or intersecting road in which the excavation exists. All warnings, in these should have a red background and should be clearly visible and legible. All warning lamps should exhibit a red light, but white lights may be used in addition to facilitate working at night. Wherever required a passage for pedestrians with footbridge should be provided. At excavations, cable drums, tools and all materials likely to offer obstructions should be properly folded round and protected. This applies to jointer's tents as well. Leads, hoses etc. stretched and across the carriageway should be guarded adequately for their own protection and also that of the public.

### **9. Traffic Control**

The police authorities are normally responsible for the control of traffic and may require the setting up of traffic controls to reduce the inconvenience occasioned by establishment of a single line of traffic due to restriction in road width or any other form of obstruction caused by the work. As far as possible, such arrangements should be settled in advance. If there are any specific regulations imposed by the local authorities, these should be followed.

### **10. Work along Railway Lines**

Normally all works at Railway crossing is to be done under supervision of the railway authorities concerned, but it is to be borne in mind that use of white, red or green flags by the Departmental staff is positively forbidden to be used when working along a railway line as this practice may cause an accident through engine drivers mistaking them for railway signals. When working along double line of railway, the men should be warned to keep a sharp look on both the "UP" and 'DOWN" lines to avoid the possibility of any accident when trains pass or happen to cross one another near the work spot.

### **11. Procedure and Safety Precautions for use of explosives during blasting for trenching**

In areas where the cable trench cannot be done manually on account of boulders and rocks, it is necessary to blast the rocks by using suitable explosives. The quality of explosive to be used depends on the nature of the rocks and the kind of boulders. A few types of explosive fuses and detonators normally used for making trenches for cable works are detailed below:

- i. Gun powder
- ii. Nitrate Mixture
- iii. Gelatine
- iv. Safety fuse
- v. Electric Detonator
- vi. Ordinary Detonator

#### **a. Procedure**

A detailed survey of the route is to be done to assess the length of the section where trenching is to be done with the help of blasting. A route diagram of the rocky section may be prepared indicating the length of the route where the explosives are to be used. For the purpose of obtaining license, a longer length of route should be given in the application as in many cases, after digging, rocks appear which was not initially anticipated.

Next a license will have to be obtained for use and storing of explosive in that section. If the area falls under a police commissioner, the authority for granting such license is the police commissioner of the concerned area. When the route does not fall in the jurisdiction of a police commissioner, the authority for issuing license is the District Magistrate.

The concerned authority from Authority should be applied in prescribed form with a route map. The concerned authority will make an enquiry and issue license for using/storing explosives for cables trenching work. Such license will be valid for 15 days only. The license should be got renewed if the blasting operation needs to be extended. Once the license is granted, it is the responsibility of the holders of the license for the proper use of explosives, its transportation and storing.

#### **b. Method of using**

The safest explosive is the Gelatin and electric detonator. Gelatin is in the form of a stick. Electric detonator is a type of fuse used for firing the explosive electrically. Holes are made at suitable intervals on rocky terrain or boulders either by air compressor or by manual chipping. The depth of the holes should be 2 to 3 ft. Fill up the holes with small quantity of sand for about 6". First the electric detonator is to be inserted into the Gelatin and the Gelatin is to be inserted into the holes keeping the + ve and - ve wirings of electric detonators outside the holes. Again refill the holes with sand. These +ve and -ve insulated wires of detonator are then extended and finally connected to an EXPLoder kept at a distance of not less than 100 m.



Now the explosive is ready for blasting. But, before connecting wires to exploder for blasting, all necessary precautions for stopping the traffic, use of red flags, exchange of caution signals, etc. should be completed and only then Exploder should be connected and operated.

**c. Operation of exploder (IDL schaffler type 350 type exploder)**

The type 350 blasting machine consists of a bearing block with blasting machine system and the explosion proof light- alloy injection moulded housing. The exploder is held with the left hand. The twist handle is applied to the drive pin, clapped with the right hand turned in the clo ck wise direction in continuous measurements at the highest speed from the initial position until it reached to a stop. At this stage an indication lamp will glow. When the indication lamp glows, “press button switch” should be pressed. This will extend the electric current to detonator and Gelatin will be detonated. The rock will be blasted out of the trench. Number of holes can be blasted in a single stroke by connecting all such detonators in series connection and finally to the exploder. After blasting, again mazdoors are engaged on the work to clear the debris. If the result of the first blasting is not satisfactory, it should be repeated again on the same place.

**d. Warning**

There may be two reasons for unsatisfactory results of the blasting

- I.** Misfire of Gelatin due to leakage of current from detonator.
- II.** Over loading because of overburdens.

Never pull the broken wire pieces form the holes in such cases. Attempt should not be made to reblast the misfired Gelatin. The safest way is to make a fresh hole by its side and put fresh Gelatin in that hole and blast it.

**12.Precautions**

The abstract of Explosives Rules 1983 which are relevant to our work is given below:

**a. Restriction of delivery and dispatch of explosives**

No person shall deliver or dispatch any explosives to anyone other than a person who is the holder of a license to possess the explosives or the agent of a holder of such a license duly authorized by him in writing on his behalf?

OR

Is entitled under these rules to possess the explosives without a license.

The explosives so delivered or dispatched shall in no case exceed the quantity, which the person to whom they are delivered or dispatched is authorized to possess with or without a license under these rules.

No person shall receive explosives form any person other than the holder of a license granted under these rules. No person shall receive from or transfer explosives to any person for a temporary storage or safe custody in a licensed premise unless prior approval is obtained from the Chief Controller.

A person holding license for possession of explosives granted under these rules shall store the explosives only in premised specified in the license.

**b. Protection from Lightening During Storing**

Every magazine shall have attached there to one or more efficient lightening conductors designed and erected in accordance with the specification laid down in Indian Standard Specifications No.2309 as amended from time to time. The connections to various parts of earth resistance of the lightening conductor terminal on the building to the earth shall be tested at least once in every year by a qualified electrical engineer or any other competent person holding a certificate of competency in this behalf from the State Electricity Department. A certificate showing the results of such tests and the date of the last test shall be hung up in conspicuous place in the building.

**c. Precautions during thunder-storm**

When a thunder- storm appears to be imminent in the vicinity of a magazine or store house every person engaged in or around such magazine and store house shall be withdrawn to a safe distance from such magazine or store house and the magazine and store house shall be kept closed and locked until the thunder storm has ceased or the threat of it has passed.

**d. Maintenance of records**

Every person holding a license granted under these rules for possession, sale or use of explosives shall maintain records in the prescribed form and shall produce such record on demand to an Inspection Officer.

**e. Explosives not to be kept in damaged boxes**

The licensee of every magazine or store house shall ensure that, the explosives are always kept in their original outer package. In case, the outer package gets damaged so that the explosive contained therein cannot be stored or transported, such explosives shall be repacked only after the same are examined by controller of explosives.

**f. Storage of explosives in excess of the licensed quantity**

The quantity of any kind of explosives kept in any licensed magazine or store house shall not exceed the quantity entered in the license against such kind of explosives. No explosives in excess of the licensed quantity shall be stored in the magazine or store house unless a permit in this behalf is obtained from the licensing authority by a letter or telegram.

**g. Precautions to be observed at Site**

The electric power at the blasting site shall be discontinued as far as practicable before charging the explosives. No work other than that associated with the charging operations shall be carried out within 10 meters of the holes unless otherwise specified to the contrary by the licensing authority.

When charging is completed, any surplus explosive detonators and fuses shall be removed from the vicinity of the hole and stored at a distance which should prevent accidental detonation in the event of a charge detonating prematurely in any hole. The holes which have been charged with explosive shall not be left unattended till the blasting is completed. Care shall be taken to ensure that fuse or wires connected to the detonation are not damaged during the placing of stemming materials and tamping.

**h. Suitable warning procedure to be maintained**

The licensee or a person appointed by the licensee to be in charge of the use of explosives at the site shall lay down a clear warning procedure consisting of warning signs and suitable signals and all persons employed in the area shall be made fully conversant with such signs and signals.

**i. Precautions to be observed while firing**

The end of the safety fuse (if used in place of a detonator should be freshly cut before being lighted. The exploders shall be regularly tested and maintained in a fit condition for use in firing. An exploder shall not be used for firing a circuit above its rated capacity. The electric circuits shall be tested for continuity before firing. All persons other than the shot-firer and his assistant, if any, shall be withdrawn from the site before testing the continuity.

For the purpose of jointing, the ends of all wires and cables should have the insulation removed for a maximum length of 5 cm. and should, then be made clear and bright for a minimum length of 2.5 cm. and the ends to be joined should be twisted together so as to have a positive metal contact. Then these should be taped with insulation to avoid leakage when in contact with earth. In case of blasting with dynamite or any other high explosive, the position of all the bore holes to be drilled shall be marked in circles with white paint. These shall be inspected by the SI's agent. Bore holes



shall be of a size that the cartridge can easily pass down. After the drilling operation, the agent shall inspect the holes to ensure that drilling has been done only at the marked locations and no extra hole has been drilled. The agent shall then prepare the necessary charge separately for each bore hole. The bore holes shall be thoroughly cleaned before a cartridge is inserted. Only cylindrical wooden tamping rods shall be used for tamping. Metal rods or rods having pointed end shall never be used for tamping. One cartridge shall be placed in the bore hole and gently pressed but not rammed down. Other cartridges shall then be added as may be required to make up the necessary charge for the bore hole. The top most cartridge shall be connected to the detonator which shall in turn be connected to the safety fuses of required length. All fuses shall be cut to the length required before being inserted into the holes. Joints in fuses shall be avoided.

Where joints are unavoidable, a semi-circular niche shall be cut in one piece inserted into the niche. The two pieces shall then be wrapped together with string. All joints exposed to dampness shall be wrapped with rubber tape.

The maximum of eight bore holes shall be loaded and fired at one occasion. The charges shall be fired successively and not simultaneously. Immediately before firing, warning shall be given and the agent shall see that all persons have retired to a place of safety. The fuses of the charged holes shall be ignited in the presence of the agent, who shall see that all the fuses are properly ignited. Careful count shall be kept by the agent and other of each blast as it explodes. In case all the charged bore holes have exploded, the agent shall inspect the site soon after the blast but in case of misfire the agent shall inspect the site after half an hour and mark red crosses (X) over the holes which have not exploded. During this interval of half an hour, nobody shall approach the misfired holes. No driller shall work near such bore until either of the following operations has been done by the agent for the misfired boreholes.

The SI's agent shall very carefully (when the tamping is a damp clay) extract the tamping with a wooden scraper and withdraw the primer and detonator.

The holes shall be cleaned for 30 cm of tamping and its direction ascertained by placing a stick in the hole. Another hole shall then be drilled 15 cm away and parallel to it. This hole shall be charged and fired. The misfired holes shall also explode along with the new one.

Before leaving the site of work, the agent of one shift shall inform the agent relieving him for the next shift, of any case of misfire and each such location shall be jointly inspected and the action to be taken in the matter shall be explained to the relieving agent. Authority shall also be informed by the agent of all cases of misfire, their cause and steps taken in that connection.

### **j. General Precautions**

For the safety of persons red flags shall be prominently displayed around the area where blasting operations are to be carried out. All the workers at site, except those who actually ignite the fuse, shall withdraw to a safe distance of at least 200 metre from the blasting site. Audio warning by blowing whistle shall be given before igniting the fuse.

Blasting work shall be done under careful supervision and trained personnel shall be employed. Blasting shall not be done within 200 meters of an existing structure, unless specifically permitted by the Authority in writing.

### **k. Precautions against misfire**

The safety fuse shall be cut in an oblique direction with a knife. All saw dust shall be cleared form inside of the detonator. This can be done by blowing down the detonator and tapping the open end. No tools shall be inserted into the detonator for this purpose. If there is water present or if the borehole is damp, the junction of the fuse and detonator shall be made water tight by means of tough grease or any other suitable material. The detonator shall be inserted into the cartridge so that about one-third of the copper tube is left exposed outside the explosive. The safety fuse just above the detonator shall be securely tied in position in the cartridge. Waster proof fuse only shall be used in the damp borehole or when water is present in the borehole. If a misfire has been found to be due to defective fuse, detonator or dynamite, the entire consignment from which the fuse,

detonator or dynamite was taken shall be inspected by the Authority or his authorized representative before resuming the blasting or returning the consignment.

**I. Precaution against stray currents**

Where electrically operated equipment is used in locations having conductive ground or continuous metal objects, tests shall be made for stray current to ensure that electrical firing can proceed safely.

**13.ALLIED ACTIVITIES**

- ξ Storing/Warehousing of Materials: SI will be responsible for storing and warehousing of all the material and accessories, but not limited to, supplied by him at his own cost. No storing/warehouse shall be provided by Authority.
- ξ Transportation of Materials: The SI shall be responsible for transporting the materials, to be supplied to execute the work under the contract, to site at his/ their own cost. The costs of transportation are subsumed in the standard quoted Rates and therefore no separate charges are payable on this account.
- ξ Disposal of Empty Cable Drums: The SI shall be responsible to dispose of the empty cable drums after laying of the cables. The cost of various sizes of empty cable drums recoverable from the SI will be fixed taking into account the prevailing market rates.
  - o It shall be obligatory on part of the SI to dispose of the empty cable drums at his/their level and the amount fixed for various empty cable drums shall be recovered from the bill for the work for which the drum (s) was/were issued or from any other amount due to the SI or the Security Deposit.
  - o The SI shall not be allowed to dump the empty cable drums in Govt. /Public place which may cause inconvenience to public. If the SI does not dispose of the empty cable drums within 3 days of becoming it empty, the Authority shall be at liberty to dispose-off the drums in any manner deemed fit and also recover the amount fixed in this contract from the bill/security deposit/ any other amount due to the SI.
- ξ Supply of Materials: There are some materials (Accessories) other than as mention in BOQ required to be supplied by the SI for execution of work under this contract like Bricks, Cement, Wire Mesh and Steel for protection, etc., besides using other consumables which do/don't become the part of the asset. The SI shall ensure that the materials supplied are of best quality and workmanship and shall be strictly in an accordance with the specifications.
- ξ Social auditing: While carrying out the execution work of cable/Equipment, videography may be carried out on sample basis for duration of 15 to 30 minutes per District which may also involve the local people of the District and same may be submitted in a form of CD along with the documentation sets for information.

## Annexure IV - Acceptance Test Procedure

PMA shall conduct all pre-defined tests for ensuring quality of work done by SI testing of OFC route from PoP to PoP Complete Installation, Integration, Commissioning and Testing of the created network which shall include OTDR link test, Power On & Self-Testing, IP-MPLS ring fail over testing for both cases i.e. in case of path/equipment failure, GPON network testing, As Build Diagram (ABD reports with optical power loss budget), integration with NOC and Final acceptance certificate For all such testing the requisite tools shall be provided by the SI to the PMA.

The Authority shall have the right to cause an audit and technical examination of the work and the final bills of the SI including all supporting vouchers, abstract etc. to be made after payment of the final bill and if as a result of such audit and technical examination any sum is found to have been overpaid in respect of any work done by the SI under the contract or any work claimed by him to have been done by him under the contract and found not to have been executed, the SI shall be liable for refund of the amount of over payment and it shall be lawful for the Authority to recover the same from SI.

- i. The Authority shall be entitled to recover any sum overpaid.
- ii. Any sum of money due and payable to the SI (including security deposit returnable to him) under this contract may be appropriated by the Authority for the payment of a sum of money arising out or under any other contract made by the SI with the Authority.

### 1. Measurement & Inspection

- i. Measurement: The measurement books are to be prepared by SI PoP-wise and are to be certified by PMA. One hard bound copy (duly signed on each page by SI and PMA) and soft copies (scanned) in three CDs will be handed over by PMA to the Authority.
- ii. Method of recording of complete nomenclature of items, as given in the agreement need not be reproduced in the measurement sheet for recording the measurement but corresponding item code as provided, shall be used.
- iii. The measurements of various items of work shall be taken and recorded in the measurements sheet. The measurements shall be taken and recorded by SI which will be countersigned by the PMA. PMA shall be directly responsible for supervision of work, shall be responsible for accuracy of 100% of measurements. All the support in terms of tools, availability of manpower at sites and all other assistance etc. shall be provided by the SI. The Authority, without any prejudice, reserves the right to carry out any kind of inspection of the works being carried out by PMA and SI at any time to ascertain its quantity and quality.
- iv. Site Images (Photographs) for PoP locations and others shall be taken by SI through Digital Cameras during Acceptance Testing and verification of measurement book. The images should be minimum resolution of 1024 x 768 pixels. The images must display the date and time of capture of the image on its bottom right corner. The digital camera should also have the capability to record the GPS co-ordinates of the location and embed the co-ordinates (Latitude, Longitude and Altitude) as EXIF data in the image. No alteration or fabrication or makeover of any kind should be made to the Site images being submitted. Site images shall be captured at every 500 meters and at PoP site. The site images are to be captured in such a manner so that the object being captured is clearly visible and the surrounding areas are also identifiable or distinguishable. The photographs shall be printed in sizes 5" x 7" (matte) and attached along with the Field Acceptance Test Report. The site images, in soft copies, are to be maintained in separate folders / directories and nomenclature as per the PoP. The site images should be so arranged such that they are easily locatable and identifiable in the folder where they are stored. The site images are to be monthly recorded on a non-erasable, good quality Compact Disk and sent to the Authority along with the Monthly Status Reports. The site images are to be uploaded and GIS co-ordinates are to be entered by SI in the project management tool and GIS tool. Printing of site images to be arranged by the SI.
- v. Method of measurement: The measurement of the work shall be done activity-wise as and when the item of work is ready for measurement. The methods of measurement of various items are enumerated as under:

- a. Measurement of length of cable: The length of cables laid on towers/poles shall be measured by use of PON OTDR. The length should be cross-verified with the marking of lengths on the cables. The lengths shall be recorded in sheet provided in the measurement book.
- b. Measurement of other items: The measurement/ numerical details of other items shall be recorded in the sheets provided for respective items viz.
  - i. Termination of Cable in equipment room
  - ii. The number of joints
  - iii. Record splice loss details for each joint.
- c. The PMA & SI shall sign all the measurement recorded in the measurement sheet/book. This will be considered as an acceptance by the PMA of measurements recorded in the MB by SI.
- d. Measurement of the work of cable for calculation of services portion will be taken equal to the length cable on pole/tower (as measured in the Roadometer) and not the total length of the cable laid through pole/tower.
- e. Measurement Book (MB): The SI shall also maintain a Measurement Book for each District. This will be maintained as compilation of copies of the measurement sheets verified by PMA. The SI shall remove all the defects pointed out by PMA in the Measurement Sheet. The PMA / SI shall also be at liberty to note their difficulties etc. in these sheets. The hard-bounded measurement sheets shall invariably be consulted at the time of making final payments to the PMA / SI.

### **2. Procedure for preparation, processing and payment of bill for works**

- a. For claiming the payment on successful completion of the milestones defined in payments Section, the SI shall prepare the bill along with testing and acceptance document of all the works, measurement books and submit the same to PMU. The final bill shall be prepared as per measurements of all items involved in execution of complete route.
- b. The PMU will scrutinize the final bill against the works entrusted and accord necessary certificates stating that the work has been executed satisfactorily in accordance with Specification and terms and condition of the contract. The PMU shall verify the quantities of items of work done by SI with reference to measurement recorded in the measurement sheet, Test reports and exercise the prescribed checks on the bills provided by SI and make recommendations for payments to Authority.

### **3. Procedure for Payment for Sub-Standard Works**

The SI is required to execute all works satisfactorily and in accordance with the Specification. If certain items of work are executed with unsound, imperfect or unskilled workmanship or with materials of any inferior description or that any materials or articles provided by him for execution of work or unsound or of a quality inferior to that contracted for or otherwise not in accordance with the contract (referred to as substandard work hereinafter), the Authority shall make a demand in writing specifying the work, materials or articles about which there is a complaint.

### **4. Timely Action by PMA**

1. Timely reporting and action, to a great extent, can prevent occurrence of sub-standard work, which will be difficult or impossible to rectify later on. It is incumbent on the part of PMA for supervision of work to point out the defects in work in time during progress of the work. The PMA responsible for supervision of work shall without any loss of time submit a report of occurrence of any sub-standard work to the Authority besides making an entry in the site order book. A notice in respect of defective work shall be given to the SI in writing during the progress of work asking the SI to rectify/replace/remove the sub-standard item of work and also definite time period within which such rectification/removal/replacement has to be done. After expiry of the notice period, if the SI fails to rectify/ replace/ remove the sub-standard items, the defects shall be

## Volume- II

---

rectified/replaced/removed by the Authority, at its sole discretion, through some other agency at the risk and cost of the SI.

2. Non-reporting of the sub-standard work in time on the part of PMA shall not in any way entitle the SI to claim that the defects were not pointed out during execution and as such the SI cannot be absolved of the responsibility for sub-standard work and associated liabilities.

### 5. Quality Control of Works

1. The importance of quality of Fibre optic cable splicing works cannot be over-emphasized. The quality and availability of long distance media and efficiency of the reliable media connectivity between terminal equipment depends upon quality of optic fibre cable plant. The quality of fibre optic cable plant depends upon the quality of individual items of work involved viz. laying, Protection, Jointing of cables and Terminations in equipment room and also on documentation of cable network. The work shall be carried out strictly in accordance with Specifications laid down to achieve the requisite quality aim.
2. The Authority shall be the final judge of the quality of the work and the satisfaction of the Authority in respect thereof set forth in the contract document. Laxity or failure to enforce compliance with the contract documents by the Authority and/ or its representative shall not manifest a change or intent of waiver, the intention being that, notwithstanding the same, the SI shall be and remain responsible for complete and proper compliance with the contract documents and the Specification there in. The representative of the Authority has the right to prohibit the use of men and any tools, materials and equipment which, in his opinion, do not produce the required work or performance meet the requirement of the contract documents.
3. It is imperative that the SI is fully conversant with the construction practices and shall be fully equipped to carry out the work in accordance with the Specifications. The SI is expected and bound to ensure quality in construction works in accordance with Specifications laid down. The SI shall engage adequate and experienced supervisors to ensure that work is carried out as per Specifications and with due diligence and in a professional manner. A two stage testing process will be incorporated as follows:
  - a. The first level of testing shall be carried out the SI. Once the SI is confirmed about the quality assurance of their work and material then they will hand it over to PMA for review and testing.
  - b. The PMA testing teams shall carry out the second level of testing.
4. In addition to Acceptance Testing being carried out by PMA, all works at all times shall be open to inspection of the Authority. The SI shall be bound, if called upon to do so, to offer the works for inspection without any extra payment. The presence of monitoring teams nominated by the Authority during construction shall not preclude separate acceptance testing teams to recheck adherence to all aspects as mentioned in the contract.

### 6. Quality Control of material supplied by SI

PMA has to ascertain that all the material being supplied by SI for Works being carried out are in compliance with the required standard and quality and as per Quality Assurance Plan. Any instance of violation by SI shall be immediately reported to the Authority by PMA.

### 7. Support Services

The SI shall ensure the availability of service, spare and expansion parts for the supplied equipment for a minimum period of 7 years from Go-Live. However, the termination of production shall not occur prior to operational acceptance by the Authority. For Fibre cable the same need to be available for 25 years.

### 8. Inspection and Testing

## Volume- II

---

1. Prior notice of at least 15 days should be given to PMA by SI for making the representative of PMA available for observing the factory tests. Any cost of pertaining to making available the PMA representative at the necessary site shall be solely borne by PMA and non-chargeable to the Authority.
2. All tests conducted by SI must be verified by PMA.
3. Should any inspections or tests indicate that specific item does not meet Specification requirements; the appropriate items shall be replaced, upgraded, or added by the SI as necessary and as applicable to correct the noted deficiencies at no cost to the Authority. After correction of a deficiency, all necessary retests shall be performed to verify the effectiveness of the corrective action.
4. Deliveries shall not be shipped until all required inspections and tests have been completed and all deficiencies have been corrected to comply with this specification and approved for shipment by the Authority.
5. Acceptance or waiver of tests will not relieve the SI from the responsibilities to furnish material and works in accordance with the specifications and to the Authority's satisfaction.
6. Unless otherwise specified in this Contract, selection of test samples, numbers of specimens and acceptance of results shall be in accordance with the terms of the relevant Standards and Codes. Where no terms exist, the Client is to instruct details in advance of the inspection and tests in response to the request of the SI.
7. SI shall comply with various instructions / guidelines issued by Authority relating to testing and acceptance of the deliverables of the SI.

### Testing Methodology

- a.** The works shall be deemed to have been completed only after the same has been accepted by PMA as per the process mentioned in this tender and after it has been informed by PMA to the Authority confirming the completion of work. The various testing will be undertaken by SI in the presence of PMA. SI may conduct its own test prior for self-assessment before asking for tests to be conducted in the presence of PMA. Certificate will be issued by PMA representative after successful completion of testing (for each milestone).
- b.** The SI, after having satisfied himself of completion of work, from FDMS/OLT at connecting POP end to FTB at end location, shall offer the work to PMA for conducting Testing.
- c.** If the measurements (of length of OFC laid) taken by PMA are found to be lesser than the measurements recorded by the SI responsible for recording the measurements, the measurement taken by PMA shall prevail without prejudice to any punitive action against the SI as per provisions of the contract and the testing officer of SI recording the measurements.
- d.** The SI shall be obligated to remove defects/deficiencies pointed out by the PMA without any additional cost. The Authority does not take any responsibility of return of defective used items / items previously accepted by SI.
- e.** Factory Acceptance Test: Factory Acceptance Tests shall be conducted as per procedure mentioned below. These tests shall be carried out in the presence of the Authority's authorized representatives unless waiver for witnessing by the Authority is intimated to the SI. Factory acceptance testing shall be carried out on OPGW/ADSS/UG, FODP, Splice enclosure, Approach cable, Test Equipment, installation accessories and all other items to be supplied unless factory testing and inspection has been waived off by the Authority.
- f.** Equipment shall not be shipped to the Authority until required factory tests are completed satisfactorily, all variances are resolved, and the Authority has issued Dispatch Clearance, which may be issued after completion of FAT by the Authority or his authorized representatives deputed for carrying out the FAT.



Successful completion of the factory tests and the Authority approval to ship shall in no way constitute final acceptance of the system or any portion thereof.

- g.** The Factory Acceptance Test (FAT) shall demonstrate the Technical characteristics of the Fibre Optic cable & associated accessories in relation to this specifications and approved drawings and documents. The list of factory acceptance tests shall be supplemented by the SI's standard FAT testing program. In general the FAT for other items shall include at least: Physical verification, demonstration of Technical characteristics, various operational modes, functional interfaces, alarms and diagnostics etc. For Test equipment, FAT shall include supply of proper calibration certificates, demonstration of satisfactory.
- h.** There shall be no factory splice allowed within a continuous length of cable. Only one continuous cable length shall be provided on each drum. The lengths of the cable to be supplied on each drum shall be determined by a "cable drum schedule" prepared by the SI after the survey duly taking into account sag, splicing, wastage, unequal heights etc. of the line route.

### **1. Fibre Optic cable link testing:**

- a.** Fibre continuity and link attenuation (Bi-directional) between FODP connectors at two ends for each fibre at 1310 and 1550 nm by OTDR
- b.** Fibre continuity and link attenuation (Bi-directional) between FODP connectors at two ends for each fibre at 1310 and 1550 nm by Power meter & Laser source
- c.** Average fibre attenuation and average splice loss in the link including FODP
- d.** Proper termination and labelling of fibre and fibre optic cables at FODP
- e.** Data loss test and ensuring that the same is within the acceptable limits

### **2. Termination arrangement at PoP location:**

At PoP location the cable shall be spliced to the pigtails for connection to the optical line systems. Pigtails shall be duly terminated at the FDMS (fibre distribution management system).

### **3. Field Acceptance Test**

- a.** The field installation test shall be performed for all equipment at each location. If any equipment has been damaged or for any reason does not comply with this Specification, the SI shall provide and install replacement parts at its own cost and expense
- b.** As per Technical requirements, the Acceptance Test is required to be carried out for all 24 Fibres in each cable section, and the Authority Acceptance Test schedule is to be followed for proper testing of the OF cable network
- c.** The OF cable sections shall be identified on ABDs attached with the Acceptance Test Report and in the GIS tool.
- d.** Testing shall be done in each OF cable section in one direction only and for two wavelengths viz. 1310 nm and 1550 nm using power meter and source. OTDR traces would be obtained for each OF Cable sections to measure and record the splice loss wherever applicable.
- e.** A minimum length of 2.0 km shall be maintained for all the ADSS cable between splices except as directed by the Client for any intermediate T-offs

### **4. End to End Testing of Optical Fibre Cable Route from PoP to PoP**

This document defines the procedure to be adopted for end to end testing of the OF cable route from POP to POPs.

- a.** The End to End testing from POP to POP shall be carried out using Power meter/source and with OTDR after splicing OF cable.
- b.** The average attenuation (dB/Km) for cable shall be recorded

- c.** End to end Testing shall be done in one direction only for the two wavelengths i.e. 1310 nm & 1550 nm from POP to POP side using Power meter and source. The Fibre connected to each port of the OTN shall also be tested using the OTDR and the traces obtained shall be recorded for future reference.
- d.** The SI entrusted with the task of for laying the incremental OF cable shall be responsible for co-ordination for conducting this test.
- e.** After carrying out this test, the respective POP shall be detected in the NMS by the central NOC team of the Authority and shown as active at the Authority NOC. The Authority shall publish the list of PoPs in each district which have gone active.
- f.** The format for End to End Testing of Cable Route shall be decided by the Authority in consultation with the PMA.

### **5. ADSS Fibre Link Length**

The estimated ADSS optical fibre lengths for various feeder lengths from one terminal point (FODP) to the other are given in the respective price schedules. However, the SI shall supply and install the optical fibre cable as required based on actual work requirements finalized after detailed site survey carried out by the SI during the project execution. The payment will be based on actual quantities of work carried out by the SI, as per the measurement criterion set forth in these specifications.

### **9. Commissioning Certificate**

- i. SI shall be eligible to apply for Commissioning Certificate of a district after successful completion of End to End testing of a district.
- ii. The End to End Testing Report has to be submitted for obtaining the Commissioning Certificate.
- iii. The Authority, without any prejudice, reserves the right to carry out any kind of inspection of the works being carried out by PMA and SI at any time to ascertain its quantity and quality.
- iv. Testing will also be done for NOC, EMS, NMS and all other components supplied by the SI as per the guidelines issued by the Authority in this regard from time to time.

### **10. Final Completion Certificate**

Only upon completion of all works as required to be done by SI for a given district, SI shall be given the Final Completion Certificate for that district by the Authority.



## **Annexure V - Fibre Cable Tests**

Following are the requirements of testing:

1. Type Testing
2. Factory Acceptance Testing
3. Site Acceptance Testing

### **1. Type Testing**

"Type Tests" shall be defined as those tests which are to be carried out to prove the design, process of manufacture and general conformity of the materials to this Specification. Type Testing shall comply with the following:

- (a) All cable & equipment being supplied shall conform to type tests as per technical specification.
- (b) The test reports submitted shall be of the tests conducted within last five (5) years for OPGW/UG cable prior to the date of proposal/offer submitted. In case the test reports are older than five (5) years for the cable on the date of proposal/offer, the SI shall repeat these tests at no extra cost to the Authority.
- (c) The SI shall submit, within 30 days of Contract Award, copies of test reports for all of the Type Tests that are specified in the specifications and that have previously (before Contract award) been performed.

These reports may be accepted by the Authority only if they apply to materials and equipment that are essentially identical to those due to be delivered under the Contract and only if test procedures and parameter values are identical to those specified in this specifications carried out at accredited labs and witnessed by third party / customer's representatives.

In the event of any discrepancy in the test reports or any type tests not carried out, same shall be carried out by SI without any additional cost implication to the Authority.

In case the Type Test is required to be carried out, then following shall be applicable:-

- (a) Type Tests shall be certified or performed by reputed laboratories using material and equipment data sheets and test procedures that have been approved by the Authority. The test procedures shall be formatted as defined in the technical specifications and shall include a complete list of the applicable reference standards and submitted for Authority approval at least four (4) weeks before commencement of test(s). The SI shall provide the Authority at least 30 days written notice of the planned commencement of each type test.
- (b) The SI shall provide a detailed schedule for performing all specified type tests. These tests shall be performed in the presence of a representative of the Authority.
- (c) The SI shall ensure that all type tests can be completed within the time schedule offered in his Technical Proposal.

In case of failure during any type test, the Supplier is either required to manufacture a fresh sample lot and repeat all type tests successfully or repeat that particular type test(s) at least three times successfully on the sample selected from the already manufactured lot at his own expenses. In case a fresh lot is manufactured for testing then the lot already manufactured shall be rejected.

#### **1.1.Type Test Samples**

The SI shall supply equipment/material for sample selection only after the Quality Assurance Plan has been approved by the Authority. The sample material shall be manufactured strictly in accordance with the approved Quality Assurance Plan. The SI shall submit for Authority approval, the type test sample selection procedure. The selection process for conducting the type tests shall ensure that samples are selected at random. For optical fibres/ Fibre Optic cables, at least three reels/ drums of each type of fibre/cable proposed shall be offered for selection.

## Volume- II

For FO cable installation hardware & fittings at least ten (10) samples shall be offered for selection. For Splice enclosures at least three samples shall be offered for selection.

### 1.2.List of Type Tests

The type testing shall be conducted on the following items

- (a) Optical fibres
- (b) OPGW Cable
- (c) OPGW Cable fittings
- (d) Vibration Damper for OPGW
- (e) Splice Enclosure (Joint Box)
- (f) Approach Cable / UG cable

### 1.2.Type Tests for Optical Fibres

The type tests listed below in the table shall be conducted on DWSM fibres to be supplied as part of overhead cables. The tests specific to the cable type are listed in subsequent sections.

S. No.	Test Name	Acceptance Criteria	Test procedure
1	Attenuation	As per Section 4 Technical Specification for Single Mode Optical Fibre	IEC 60793-1-40 Or EIA/TIA 455-78A
2	Attenuation Variation with wavelength	As per Section 4 Technical Specification for Single Mode Optical Fibre	IEC 60793-1-40 Or EIA/TIA 455-78A
3	Attenuation at Water Peak	As per Section 4 Technical Specification for Single Mode Optical Fibre	IEC 60793-1-40 Or EIA/TIA 455-78A
4	Temp. Cycling (Temp dependence of Attenuation)	As per Section 4 Technical Specification for Single Mode Optical Fibre	IEC 60793-1-52 Or EIA/TIA 455-3A, 2 cycles
5	Attenuation With Bending (Bend Performance)	As per Section 4 Technical Specification for Single Mode Optical Fibre	IEC 60793-1-47 Or EIA/TIA 455-62A
6	Mode Field dia.	As per Section 4 Technical Specification for Single Mode Optical Fibre	IEC 60793-1-45 Or EIA/TIA 455-164A/167A/174
7	Chromatic Dispersion	As per Section 4 Technical Specification for Single Mode Optical Fibre	IEC 60793-1-42 Or EIA/TIA 455-168A/169A/175A
8	Cladding Diameter	As per Section 4 Technical Specification for Single Mode Optical Fibre	IEC 60793-1-20 Or EIA/TIA 455-176
9	Point Discontinuities of attenuation	As per Section 4 Technical Specification for Single Mode Optical Fibre	IEC 60793-1-40 Or EIA/TIA 455-78A

**Volume- II**

S. No.	Test Name	Acceptance Criteria	Test procedure
10	Core -Clad concentricity error	As per Section 4 Technical Specification for Single Mode Optical Fibre	IEC 60793-1-20 Or EIA/TIA 455-176
11	Fibre Tensile Proof Testing	As per Section 4 Technical Specification for Single Mode Optical Fibre	IEC 60793-1-30 Or EIA/TIA 455-31B

Table 114: Type Tests for Optical Fibres

**1.2.Type Tests for OPGW Cables**

The type tests to be conducted on the OPGW cable are listed in the below table, Type Tests for OPGW Cables. Unless specified otherwise in the technical specifications or the referenced standards, the optical attenuation of the specimen, measured during or after the test as applicable, shall not increase by more than 0.05 dB/Km.

S. No.	Test Name	Test Description	Test Procedure
1	Water Ingress Test	IEEE 1138 – 2009	IEEE 1138-2009 (IEC 60794-1-2 Method F5 or EIA/TIA 455-82B) Test duration : 24 hours
2	Seepage of filling compound	IEEE 1138-2009	IEEE 1138-2009 Preconditioning period: 72 hours.
			EIA/TIA 455-81B) Test duration: 24 hours.
3	Short Circuit Test	IEEE 1138-2009	IEEE 1138-2009 Fibre attenuation shall continuously monitored and recorded through a data logging system or equivalent means a suitable temperature sensor such as thermocouple shall be used to monitor and record the temperature inside the OPGW tube in addition to monitoring & recording the temperatures between the strands and between optical tube and the strand as required by IEEE 1138. Test shall be conducted with the tension clamps proposed to be supplied. The cable and the clamps shall be visually inspected for mechanical damage and photographed after the test.
		Or IEC60794-4-10 / IEC 60794-1-2 - 2003 Method H1	Initial temperature during the test shall be greater than or equal to ambient temperature

**Volume- II**

S. No.	Test Name	Test Description		Test Procedure
4	Aeolian Vibration Test	IEEE 1138-2009 Or IEC60794-4-10 / IEC 60794-1-2, Method E19	IEEE 1138-2009	Fibre attenuation shall continuously monitored and recorded through a data logging system or equivalent means The vibration frequency and amplitude shall be monitored and recorded continuously. All fibres of the test cable sample shall be spliced together in serial attenuation monitoring. Test shall be conducted with tension / suspension clamps proposed to supplied. The cable and the clamps shall be visually inspected for mechanical damage and photographed after the test.
5	Galloping test	IEEE 1138-2009	IEEE 1138-2009	Test shall be conducted with the tension / suspension clamps proposed to be supplied. The cable and clamps shall be visually inspected for mechanical damage and photographed after the test. All fibres of the test cable sample shall be spliced together in serial for attenuation monitoring.
6	Cable Bend Test	Procedure 2 in IEC 60794-1-2 Method E11		The short-term and long-term bend tests shall be conducted in accordance with Procedure 2 in IEC 60794-2 E11 to determine the minimum acceptable radius of bending without any increase in attenuation or any other damage to the fibre optic cable core such as bird caging, deformation, kinking and crimping.
7	Sheave Test	IEEE 1138-2009 Or IEC 60794-1-2-2003 Method E1B	IEEE 1138-2009	Fibre attenuation shall be continuously monitored and recorded through a digital data logging system or equivalent means. The sheave dia. Shall be based on the pulling angle and the minimum pulley dia employed during installation. All fibres of the test cable sample shall be spliced together in serial for attenuation monitoring.

## Volume- II

S. No.	Test Name	Test Description	Test Procedure
8	Crush Test	IEEE 1138-2009	IEEE 1138-2009 (IEC 60794-1-2, Method E3/EIA/TIA 455-41B) The crush test shall be carried out on a sample of approximately one (1) meter long in accordance with IEC 60794-1-2 E3. A load equal to 1.3 times the weight of a 400-metre length of fibre optic cable shall be applied for a period of 10 minutes. A permanent or temporarily increase in optical attenuation value greater than 0.1dB change in sample shall constitute failure. The load shall be further increased in small increments until the measured attenuation of the optical waveguide fibres increases and failure load recorded along with results.
9	Impact Test	IEEE 1138-2009	IEEE 1138-2009, (IEC 60794-1-2, E4/ EIA/TIA 455-25B) The impact test shall be carried out in accordance with IEC 60794-1-2 E4. Five separate impacts of 0.1 - 0.3 Kgs shall be applied. The radius of the intermediate piece shall be the reel drum radius +/- 10%. A permanent or temporary increase in optical attenuation value greater than 0.1 dB/Km change in sample shall be constitute failure.
10	Creep Test	IEEE 1138-2009	IEEE 1138-2009 As per Aluminium Association Method, the best fit straight line shall be fitted to the recorded creep data and shall be extrapolated to 25 years. The strain margin of the cable at the end of 25 years shall be calculated. The time when the creep shall achieve the strain margin limits shall also be calculated.
11	Fibre Strain test	IEEE 1138-1994	IEEE 1138-1994
12	Strain Margin Test	IEEE 1138-2009	IEEE 1138-2009
13	Stress strain Test	IEEE 1138-2009	IEEE 1138-2009
14	Cable Cut-off wave length Test	IEEE 1138-1994	IEEE 1138-1994
15	Temperature Cycling Test	IEEE 1138-2009	IEEE 1138-2009 Or IEC 60794-1-2, Method F1
16	Corrosion (Salt Spray) Test	EIA/TIA 455-16A	

## Volume- II

S. No.	Test Name	Test Description	Test Procedure
17	Tensile Performance Test	IEC 60794-1-2 E1 / EIA/TIA 455-33B	The test shall be conducted on a sample of sufficient length in accordance with IEC 60794-1-2 E1. The attenuation variation shall not exceed 0.05 dB/Km up to 90% of RTS of fibre optic cable. The load shall be increased at a steady rate up to rated tensile strength and held for one minute. The fibre optic cable sample shall not fail during the period. The applied load shall then be increased until the failing load is reached and the value recorded.
18	Lightning test	IEC 60794-4-10 / IEC 60794-1-2 (2003)	The OPGW cable construction shall be tested in accordance with IEC 60794-1-2, Method H2 for Class 1.
19	DC Resistance Test	IEC 60228	On a fibre optic cable sample of minimum 1 metre length, two contact clamps shall be fixed with a predetermined bolt torque. The resistance shall be measured by a Kelvin double bridge by placing the clamps initially zero metre and subsequently one metre apart. The tests shall be repeated at least five times and the average value recorded after correcting at 20°C.

Table 115: Type Tests for OPGW

### 1.2.3 Type Test on OPGW Cable Fittings

The type tests to be conducted on the OPGW Cable fittings and accessories are listed below:

#### (i) Mechanical Strength Test for Suspension/Tension Assembly

Applicable Standards: IEC 61284, 1997.

##### 1) Suspension Assembly

The armour rods /reinforcement rods are assembled on to the approved OPGW using the Installation Instructions to check that the assembly is correctly fitted and is the same that will be carried out during installations.

##### Part 1:

The suspension assembly shall be increased at a constant rate up to a load equal to 50% of the specified minimum Failure Load increased and held for one minute for the test rig to stabilise. The load shall then be increased at a steady rate to 67% of the minimum Failure Load and held for five minutes. The angle between the cable, the Suspension Assembly and the horizontal shall not exceed 16°. This load shall then be removed in a controlled manner and the Protection Splice disassembled. Examination of all the components shall be made and any evidence of visual deformation shall be documented.

##### Part 2:

## Volume- II

---

The Suspension clamp shall then be placed in the testing machine. The tensile load shall gradually be increased up to 50% of the specified Minimum Failure Load of the Suspension Assembly and held for one minute for the Test Rig to stabilise and the load shall be further increased at a steady rate until the specified minimum Failure Load is reached and held for one minute. No fracture should occur during this period. The applied load shall then be increased until the failing load is reached and the value shall be documented.

### **2) Tension Assembly**

The Tension Assembly is correctly fitted and is the same that will be carried out during installations.

#### **Part 1:**

The tension assembly (excluding tension clamp) shall be increased at a constant rate up to a load equal to 50% of the specified minimum Failure Load increased at a constant rate and held for one minute for the test rig to stabilise. The load shall then be increased at a steady rate to 67% of the minimum Failure Load and held for five minutes. This load shall then remove in a controlled manner and the Tension Assembly disassembled. Examination of the Tension Dead-End and associated components shall be made and any evidence of visual deformation shall be documented.

#### **Part 2:**

The Tension Dead-End and associated components shall then be reassembled and bolts tightened as before. The tensile load shall gradually be increased up shall gradually be increased up to 50% of the specified Minimum Failure Load of the Tension Assembly and held for one minute for the Test Rig to stabilise and the load shall be further increased at a steady rate until the specified minimum Failure Load is reached and held for one minute. No fracture should occur during this period. The applied load shall then be increased until the failing load is reached and the value shall be documented.

Acceptance Criteria for Tension/Suspension Assembly:

- (a) No evidence of binding of the Nuts or Deformation of components at end of Part 1 of Test.
- (b) No evidence of Fracture at the end of one minute at the minimum failure load during Part 2 of the Test.

Any result outside these parameters shall constitute a failure.

### **(ii) Clamp Slip Strength Test for Suspension Assembly**

The suspension assembly shall be vertically suspended by means of a flexible attachment. A suitable length fibre optical cable shall be fixed in the clamps. Once the Suspension Clamp has been assembled, the test rig is tensioned to 1 kN and the position scale on the recorder 'zeroed'. The test rig is then tensioned to 2.5 kN and the relative positions of the Reinforcing Rods, Armour Rods and Suspension Clamp shall be marked by a suitable means to confirm any slippage after the test has been completed. The relative positions of the helical Armour Rods and associated Reinforcing Rods at each end shall be marked and also 2 mm relative position between clamp body and Armour Rods shall be marked on one side. The load shall be increased to 12 kN at a loading rate of 3 kN/min and held for one minute. At the end of this one minute period, the relative displacement between clamp body and the armour rods shall be observed. If the slippage is 2 mm or above, the test shall be terminated. Otherwise, at the end of one minute the position of the clamp body and 2 mm. relative positions between clamp body and armour rods shall be marked on the other side. After the one minute pause, the load shall be further increased at a loading rate of 3 kN/min, and recording of load and displacement shall continue until either the relative Position displacement between clamp body and armour rods reaches more than 2 mm or the load reaches the maximum slip load of 17 kN. On reaching either of the above values the test is terminated. Visual examination of all paint marks shall be recorded, and a measurement of any displacement recorded in the Table of Results.

#### **Acceptance Criteria:**

## Volume- II

---

The Suspension Clamp has passed the Slip Test if the following conditions are met:

- 1) No slippage\* shall occur at or below the specified minimum slip load.  
\* Definition of no slippage in accordance with IEC 61284, 1997:- Any relative movement less than 2 mm is accepted. The possible couplings or elongations produced by the cable as a result of the test itself are not regarded as slippage.
- 2) Slippage shall occur between the specified maximum and minimum slip load of 12 - 17 kN.
- 3) There shall be no slippage of the Reinforcing Rods over the cable, and no slippage of the Armour Rods over the Reinforcing Rods.
- 4) The relative movement (i.e. more than 2 mm between Armour Rods & Clamp body) between minimum 12 kN and maximum slip 17 kN, shall be considered as slip.
- 5) The Armour Rods shall not be displaced from their original lay or damaged\*\*.  
\*\*Definition of no damage in accordance with convention expressed in IEC 61284: 1997 no damage, other than surface flattening of the strands shall occur.

Any result outside these parameters is a failure.

### **(iii) Slip Strength Test of Tension Clamp**

Tension clamps shall be fitted on an 8 m length of fibre optic cable on both ends. The assembly shall be mounted on a tensile testing machine and anchored in a manner similar to the arrangement to be used in service. A tensile load shall gradually be applied up to 20 % of the RTS of OPGW. Displacement transducers shall be installed to measure the relative movement between the OPGW relative to the Reinforcing Rods and Tension Dead -End relative to Reinforcing Rods. In addition, suitable marking shall be made on the OPGW and Dead-End to confirm grip. The load shall be gradually increased at a constant rate up to 50 % of the UTS and the position scale of the recorder is zeroed. The load shall then gradually increased up to 95 % of the UTS and maintained for one minute. After one minute pause, the load shall be slowly released to zero and the marking examined and measured for any relative movement.

#### **Acceptance Criteria:**

- 1) No movement\* shall occur between the OPGW and the Reinforcing Rods, or between the Reinforcing Rods and the Dead-End assembly.
- 2) No failure or damage or disturbance to the lay of the Tension Dead-End, Reinforcing Rods or OPGW.  
\* Definition of no movement as defined in IEC 61284: Any relative movement less than 2 mm is accepted.  
The possible couplings or elongations produced by the conductor as a result of the test itself are not regarded as slippage.

Any result outside these parameters shall constitute a failure.

### **(iv) Grounding Clamp and Structure Mounting Clamp Fit Test**

For structure mounting clamp, one series of tests shall be conducted with two fibre optic cables installed, one series of tests with one fibre optic cable installed in one groove, and one series of tests with one fibre optic cable in the other groove. Each clamp shall be installed including clamping compound as required on the fibre optic cable. The nut shall be tightened on to the bolt by using torque wrench with a torque of 5.5 kgm or supplier's recommended torque and the tightened clamp shall be held for 10 minutes. After the test remove the fibre optic cable and examine all its components for distortion, crushing or breaking. Also the fibre optic cable shall be checked to ensure free movement within the core using dial callipers to measure the diameter of the core tube. The material shall be defined as failed if any visible distortion, crushing, cracking or breaking of the core tube is observed or the fibre optic cable within the core tube is not free to move, or when the diameter of the core tube as measured at any location in the clamped area is more than 0.5 mm larger or smaller of the core diameter as measured outside the clamped area.



**(v) Structure Mounting Clamp Strength Test**

The clamp and mounting assembly shall be assembled on a vertical 200 mm x 200 mm angle and a short length of fibre optic cable installed. A vertical load of 200 kg shall be applied at the end of the mounting clamp and held for 5 minutes. Subsequently, the load shall be increased to 400 kg and held for 30 seconds. Any visible distortion, slipping or breaking of any component of the mounting clamp or assembly shall constitute failure.

**1.2.4 Type Test on Vibration Damper**

**(a) Dynamic Characteristic Test**

The damper shall be mounted with its clamp tightened with torque recommended by the manufacturer on shaker table capable of simulating sinusoidal vibrations for Critical Aeolian Vibration frequency band ranging from  $0.18/d$  to  $1.4/d$  – where  $d$  is the OPGW cable diameter in meters. The damper assembly shall be vibrated vertically with a  $\pm 1$  mm amplitude from 5 to 15 Hz frequency and beyond 15 Hz at 0.5 mm to determine following characteristics with the help of suitable recording instruments.

- (i) Force Vs frequency
- (ii) Phase angle Vs frequency
- (iii) Power dissipation Vs frequency

The Force Vs frequency curve shall not show steep peaks at resonance frequencies and deep troughs between the resonance frequencies. The resonance frequencies shall be suitably spread within the Aeolian vibration frequency band between the lower and upper dangerous frequency limits determined by the vibration analysis of fibre optic cable without dampers.

Acceptance criteria for vibration damper:

- (i) The above dynamic characteristics test on five damper shall be conducted.
- (ii) The mean reactance and phase angle Vs frequency curves shall be drawn with the criteria of best fit method.
- (iii) The above mean reactance response curve should lie within following limits: V.D. for OPGW -  $0.060 f$  to  $0.357 f$  kgf/mm\*  
Where  $f$  is frequency in Hz.
- (iv) The above mean phase angle response curve shall be between  $25^\circ$  to  $130^\circ$  within the frequency range of interest.
- (v) If the above curve lies within the envelope, the damper design shall be considered to have successfully met the requirement.
- (vi) Visual resonance frequencies of each mass of damper is to be recorded and to be compared with the guaranteed values.

**(b) Vibration Analysis**

The vibration analysis of the fibre optic cable shall be done with and without damper installed on the span. The vibration analysis shall be done on a digital computer using energy balance approach. The following parameters shall be taken into account for the purpose of analysis.

- (i) The analysis shall be done for single fibre optic cable without armour rods. The tension shall be taken as 25% of RTS of fibre optic cable for a span ranging from 100 m to 1100 m.
- (ii) The self damping factor and flexural stiffness (EI) for fibre optic cable shall be calculated on the basis of experimental results. The details to experimental analysis with these data shall be furnished.
- (iii) The power dissipation curve obtained from Damper Characteristics Test shall be used for analysis with damper.

- (iv) Examine the Aeolian Vibration level of the fibre optic cable with and without vibration damper installed at the recommended location or wind velocity ranging from 0 to 30 Km per hour, predicting amplitude, frequency and vibration energy input.
- (v) From vibration analysis of fibre optic cable without damper, antinode vibration amplitude and dynamic strain levels at clamped span extremities as well as antinodes shall be examined and thus lower and upper dangerous frequency limits between which the Aeolian vibration levels exceed the specified limits shall be determined.
- (vi) From vibration analysis of fibre optic cable with damper(s) installed at the recommended location, the dynamic strain level at the clamped span extremities, damper attachment point and the antinodes on the fibre optic cable shall be determined. In addition to above damper clamp vibration amplitude and antinodes vibration amplitudes shall also be examined.

The dynamic strain levels at damper attachment point, clamped span extremities and antinodes shall not exceed the specified limits. The damper clamp vibration amplitude shall not be more than that of the specified fatigue limits.

### **(c) Fatigue Tests**

#### **(i) Test Set Up**

The fatigue tests shall be conducted on a laboratory set up with a minimum effective span length of 30m. The fibre optic cable shall be tensioned at 25% of RTS of fibre optic cable and shall not be equipped with protective armour rods at any point.

Constant tension shall be maintained within the span by means of lever arm arrangement.

After the fibre optic cable has been tensioned, clamps shall be installed to support the fibre optic cable at both ends and thus influence of connecting hardware fittings are eliminated from the free span. The clamps shall not be used for holding the tension on the fibre optic cable. There shall be no loose parts, such as suspension clamps, U bolts, on the test span supported between clamps mentioned above. The span shall be equipped with vibration inducing equipment suitable for producing steady standing vibration. The inducing equipment shall have facilities for step less speed control as well as step less amplitude arrangement. Equipment shall be available for measuring the frequency, cumulative number of cycles and amplitude of vibration at any point along the span.

#### **(ii) Fatigue Test**

The vibration damper shall be installed on the test span with the manufacturer's specified tightening torque. It shall be ensured that the damper shall be kept minimum three loops away from the shaker to eliminate stray signals influencing damper movement.

The damper shall then be vibrated at the highest resonant frequency of each damper mass. For dampers involving torsional resonant frequencies, tests shall be done at torsional modes also in addition to the highest resonant frequencies at vertical modes. The resonance frequency shall be identified as the frequency at which each damper mass vibrates with the maximum amplitude on itself. The amplitude of vibration of the damper clamp shall be maintained not less than  $\pm 25/f$  mm where f is the frequency in Hz.

The test shall be conducted for minimum ten million cycles at each resonant frequency mentioned above. During the test, if resonance shift is observed, the test frequency shall be tuned to the new resonant frequency.

The clamp slip test as mentioned herein shall be repeated after fatigue tests without re-torquing or adjusting the damper clamp, and the clamp shall withstand a minimum load equal to 80% of the slip strength for a minimum duration of one minute.

After the above tests, the damper shall be removed from fibre optic cable and subjected to dynamic characteristics test. There shall not be any major deterioration in the characteristics of the damper. The damper then shall be cut open

## Volume- II

and inspected. There shall not be any broken, loose, or damaged part. There shall not be significant deterioration or wear of the damper. The fibre optic cable under clamp shall also be free from any damage.

For purposes of acceptance, the following criteria shall be applied:

- (1) There shall not be any resonant frequency shift before and after the test by more than  $\pm 20\%$
- (2) The power dissipation of the damper before and after test at the individual resonant frequencies do not differ by more than  $\pm 20\%$

Beside above tests, the type tests listed below in the table shall also be conducted on Vibration Damper

SI No.	Test Name	Test Procedure
1	Visual examination & Dimensional and material verification	IEC 61897 Clause 7.1 & 7.2
2	Clamp Slip test	IEC 61897 Clause 7.5
3	Clamp bolt tightening test	IEC 61897
4	Attachments of weight to messenger cable	IEC 61897 Clause 7.8
5	Attachment of clamps to messenger cable	IEC 61897 Clause 7.8
6	Damper effectiveness evaluation	IEC 61897 Clause 7.11.3.2

Table 116: Additional Tests for Vibration Dampers

### 1.2.5 Type Tests for Splice Enclosures (Joint Box)

Following Type tests shall be demonstrated on the Splice Enclosure(s) (Splice Enclosure/Box). For certain tests, lengths of the fibre optic cable shall be installed in the splice box, and the fibres must be spliced and looped in order to simulate conditions of use. The attenuation of the fibres shall be measured, during certain tests, by relevant Fibre Optic Test Procedures (EIA/TIA 455 or IEC 60794-1 procedures).

#### (i) Temperature Cycling Test

FO cable is installed in the splice enclosure and optical fibres spliced and looped. The box must be subjected to 5 cycles of temperature variations of -40 degree Celsius to +65 degree Celsius with a dwell time of at least 2 hours on each extreme.

Fibre loop attenuation shall be measured in accordance with EIA 455-20 / IEC 60794-1-C10. The variation in attenuation shall be less than  $\pm 0.05\text{dB}$ . The final humidity level, inside the box, shall not exceed the initial level, at the closing of the box.

#### (ii) Humid Heat test

The sealed splice enclosure, with fibres spliced and looped inside, must be subjected to a temperature of +55 deg. C  $\pm 2$  deg. C with a relative humidity rate of between 90% and 95% for 5 days. The attenuation variation of the fibres during the duration of the test shall be less than  $\pm 0.05\text{dB}$ , and the internal humidity rate measured, less than 2%.

#### (iii) Rain Withstand Test / Water Immersion test

## Volume- II

The splice enclosure with optical fibres cable installed and fibres spliced fixed, shall be subjected to 24 hours of simulated rain in accordance with IEC 60060 testing requirements. No water seepage or moisture shall be detected in the splice enclosure. The attenuation variation of the fibres after the test shall be less than  $\pm 0.05\text{dB}$ .

### (iv) Vibration Test

The splice enclosure, with fibres united inside, shall be subjected to vibrations on two axes with a frequency scanning of 5 to 50 Hz. The amplitude of the vibrations shall be constant at 0.450mm, peak to peak, for 2 hours, for each of the vibrations' axes. The variation in attenuation, of the fibres, shall be less than  $\pm 0.05\text{dB}$ . The splice enclosure shall be examined for any defects or deformation. There shall be no loosening or visible damage of the FO cable at the entry point.

### (v) Bending and Torsion test

The splice enclosure, with fibres spliced inside, shall be firmly held in place and be subjected to the following sequence of mechanical stresses on the cable:

- a) 3 torsion cycles of  $\pm 180\text{deg}$ . shall be exercised on the cable. Each cycle shall be less than one minute.
- b) 3 flexure cycles of the cable, of  $\pm 180\text{deg}$ . with one cycle less than one minute.

The variation in the attenuation, of the fibres, shall be less than  $\pm 0.05\text{dB}$ . The cables connection ring shall remain securely fixed to the box with the connection maintained firmly. No defects/fissures shall be noted on the joint ring or on the splice enclosure

### (vi) Tensile test

The splice enclosure with cable fixed to the boxes shall be subjected to a minimum tension of 448 N for a period of two minutes. No fissure shall be noted in the connections or on the box.

### (vii) Drop Test

With 2 lengths of 11 metres of cable fixed to the box, it shall be dropped five times from a height of 10 metres. There shall be no fissure, at all, of the box, and the connections shall remain tight. The test surface shall be carried out in accordance with IEC 60068-2-32.

## 1.2.6 Type Tests for Fibre Optic Approach Cable/UG cable

The type tests to be conducted on the Fibre Optic Approach cable are listed in table below. Type Tests for Fibre Optic Approach Cable. Unless specified otherwise in the technical specifications or the referenced standards, the optical attenuation of the specimen, measured during or after the test as applicable, shall not increase by more than 0.05 dB/Km.

Sl. No.	Test Name	Test Procedure
1	Water Ingress Test	(IEC 60794-1-F5 / EIA 455-82B) Test duration : 24 hours
2	Seepage of filling compound	(EIA 455-81A) Preconditioning: 72 hours, Test duration : 24 hours.
3	Crush Test	(IEC 60794-1-E3/ EIA 455-41)
4	Impact Test	(IEC-60794-1-E4/ EIA 455-25A)
5	Stress strain Test	(EIA 455-33A)

## Volume- II

Sl. No.	Test Name	Test Procedure
6	Cable Cut-off wavelength Test	(EIA 455-170)
7	Temperature Cycling Tests	(IEC60794-1-F1/EIA-455-3A) - 2 cycles

Table 117: Type Tests Fibre Optic Approach Cable

### Impact Test

The Impact test shall be carried out in accordance with IEC:60794-1-E4. Five separate impacts of 2.0 kg shall be applied at different locations. The radius of the intermediate piece shall be the reel drum radius  $\pm 10\%$ . A permanent or temporary increase in optical attenuation value greater than 0.05 dB/km shall constitute failure.

#### 1.3.Factory Acceptance Tests

Factory acceptance tests shall be conducted on randomly selected final assemblies of all equipment to be supplied. Factory acceptance testing shall be carried out on OPGW Cable and associated hardware & fittings, Approach Cable, Joint Box, FODP, FTB, FDMS, etc. and all other items for which price has been identified separately in the Bid Price Schedules.

Material shall not be shipped to the Authority until required factory tests are completed satisfactorily, all variances are resolved, full test documentation has been delivered to the Authority, and the PMA has issued Material Inspection & Clearance Certificate (MICC). Successful completion of the factory tests and the Authority approval to ship, shall in no way constitute final acceptance of the system or any portion thereof. These tests shall be carried out in the presence of the PMA and Authority's authorized representatives unless waiver for witnessing by Authority's representatives is intimated to the SI.

Factory acceptance tests shall not proceed without the prior delivery to and approval of all test documentation by the Authority.

The factory acceptance tests for the supplied items shall be proposed by the SI in accordance with technical specifications and SI's (including Sub-contractor's / supplier's) standard FAT testing program. In general the FAT for other items shall include at least: Physical verification, demonstration of technical characteristics, various operational modes, functional interfaces etc.

For Test equipment FAT shall include supply of proper calibration certificates, demonstration of satisfactory performance, evidence of correct equipment configuration and manufacturer's final inspection certificate/ report.

#### 1.3.Sampling for FAT

From each batch of equipment presented by the SI for Factory acceptance testing, the Authority shall select random sample(s) to be tested for acceptance. Unless otherwise agreed, all required FAT tests in the approved FAT procedures, shall be performed on all samples. The Sampling rate for the Factory acceptance tests shall be minimum 10% of the batch size (minimum 2) for all items. The physical verification shall be carried out on 100% of the offered quantities as per the approved FAT procedure. In case any of the selected samples fail, the failed sample is rejected and additional 20% samples shall be selected randomly and tested. In case any sample from the additional 20% also fails the entire batch may be rejected.

For the cable hardware fittings & accessories, the minimum sampling rate, and batch acceptance criteria shall be as defined in IS 2486.

The Sampling rate for the Factory acceptance tests shall be 10% of the batch size (minimum 2) for FO cable drums, FODPs, Joint box and other similar items.

Since FAT testing provides a measure of assurance that the Quality Control objectives are being met during all phases of production, the Authority reserves the right to require the SI to investigate and report on the cause of FAT failures and to suspend further testing/ approvals until such a report is made and remedial actions taken, as applicable.

**1.3. Production Testing**

Production testing shall mean those tests which are to be carried out during the process of production by the SI to ensure the desired quality of end product to be supplied by him. The production tests to be carried out at each stage of production shall be based on the SI's standard quality assurance procedures. The production tests to be carried out shall be listed in the Manufacturing Quality Plan (MQP), along with information such as sampling frequency, applicable standards, acceptance criteria etc.

The production tests would normally not be witnessed by the Authority. However, the Authority reserves the right to do so or inspect the production testing records in accordance with Inspection rights specified for this contract.

**1.3.3. Factory Acceptance Tests on Optical Fibre to be supplied with OPGW/ADSS/A Cable /Drop cable**

The factory acceptance tests listed in the table below are applicable for the optical fibres to be supplied. The listed tests follow testing requirements set forth in IEEE standard 1138/IEC 60794. The referenced sections specify the detailed test description. The acceptance norm shall be as specified in the above mentioned IEEE standards unless specified otherwise in the technical specifications.

S. No.	Test Name	Acceptance Criteria	Test procedure
1	Attenuation Coefficient	As per Section 4 Technical Specification for Single Mode Optical Fibre	EIA/TIA 455- 78A
2	Point Discontinuities of attenuation	As per Section 4 Technical Specification for Single Mode Optical Fibre	EIA/TIA 455-59
3	Attenuation at Water Peak	As per Section 4 Technical Specification for Single Mode Optical Fibre	EIA/TIA 455- 78A 168A/169A/175A
4	Chromatic Dispersion	As per Section 4 Technical Specification for Single Mode Optical Fibre	EIA/TIA 455-
5	Core - Clad Concentricity Error	As per Section 4 Technical Specification for Single Mode Optical Fibre	EIA/TIA 455-/176
6	Cladding diameter	As per Section 4 Technical Specification for Single Mode Optical Fibre	EIA/TIA 455-176
7	Fibre Tensile Proof Testing	As per Section 4 Technical Specification for Single Mode Optical Fibre	EIA/TIA 455-31B

*Table 118: Factory Acceptance Tests*

## Volume- II

The test report for the above tests for the fibres carried out by the Fibre Manufacturer and used in the OPGW/ADSS/UG cables shall be shown to the inspector during the respective cable's FAT and shall be submitted along with the FAT report.

### 1.3.4 Factory Acceptance Test on OPGW Cable

The factory acceptance tests for OPGW cable specified below in the table follow the requirements set forth in IEEE standard 1138 / IEC 60794. The FAT shall be carried out on 10% of offered drums in each lot as specified in technical specifications and the optical tests shall be carried out in all fibres of the selected sample drums. The Rated Tensile Strength test shall be carried out on one sample in each lot.

Sl. No.	Factory Acceptance Test on Manufactured OPGW
1	Attenuation Co-efficient at 1310 nm and 1550 nm
2	Point discontinuities of attenuation
3	Visual Material verification and dimensional checks as per ap-proved DRS/Drawings
4	Rated Tensile Strength
5	Lay Length Measurements

Table 119: Factory Acceptance Tests on OPGW

### 1.3.5 Factory Acceptance Test on OPGW Fittings

The factory acceptance tests for OPGW Fittings as specified below in the table. The sampling plan shall be as per relevant standard:

Sl. No.	Factory Acceptance Test
<b>Suspension Assembly</b>	
1	UTS/Mechanical Strength of the assembly
2	Clamp Slip Test
3	Visual Material verification and dimensional checks as per ap-proved DRS/Drawings
4	Mechanical strength of each component
5	Galvanizing test
<b>Tension Assembly</b>	
6	Clamp Slip Strength test
7	Visual Material verification and dimensional checks as per ap-proved DRS/Drawings
8	Mechanical strength of each component
9	Galvanizing Test
<b>Vibration Damper</b>	
10	Galvanizing test on damper, masses and messenger wires

<b>Sl. No.</b>	<b>Factory Acceptance Test</b>
11	Damper response (resonant frequencies)
12	Clamp Slip test
13	Strength of messenger wires
14	Attachments of weights to messenger cable
15	Attachments of clamps to messenger cable
16	Clamp bolt tightening test
17	Clamp bolt torque test
18	Dynamic characteristic test.
19	Visual Material verification and dimensional checks as per approved DRS/Drawings
<b>Structure Mounting Clamp</b>	
20	Clamp fit test
21	Clamp Strength test
22	Visual Material verification and dimensional checks as per approved DRS/Drawings

*Table 120: Factory Acceptance Tests on OPGW Fittings & Accessories*

**1.3.6. Factory Acceptance Test on Approach/UG Cable**

The factory acceptance tests for Approach Cable specified below in the Table.

<b>Sl. No.</b>	<b>Factory Acceptance Test</b>
1	Attenuation Co-efficient at 1310 nm and 1550 nm
2	Point discontinuities of attenuation
3	Visual Material verification and dimensional checks as per approved DRS/Drawings

*Table 121: Factory Acceptance Tests on Approach Cable*

**1.3.7. Factory Acceptance Test on all Passive Accessories**

The factory acceptance tests for all passive accessories like Splice Enclosures/FODP, FTB, FDMS, etc. as specified below in table

<b>S. No.</b>	<b>Factory Acceptance Test</b>
1	Visual check of Quantities and Specific Component Number for each component of each passive item and dimensional checks against the approved drawings.

*Table 122: Factory Acceptance Tests on passive accessories*

**1.3.8. Factory Acceptance Test on Test Equipment & other items**

As per technical specification and approved DRS/Documents.



### **1.4.Site Acceptance Tests**

The SI shall be responsible for the submission of all material & test equipment supplied in this contract for site tests and inspection as required by the Authority. All equipment shall be tested on site under the conditions in which it will normally operate.

The tests shall be exhaustive and shall demonstrate that the overall performance of the contract works satisfies every requirement specified. At a minimum Site Acceptance Testing requirement is outlined below. This testing shall be supplemented by the SI's standard installation testing program, which shall be in accordance with his quality plan(s) for FO installation.

During the course of installation, the Authority/its designated officers shall have full access for inspection and verification of the progress of the work and for checking workmanship and accuracy, as may be required. On completion of the work prior to commissioning, all equipment shall be tested to the satisfaction of the Authority to demonstrate that it is entirely suitable for commercial operation.

#### **1.4. Minimum Site Acceptance Testing Requirement for FO Cabling**

Prior to installation, every spooled fibre optic cable segment shall be tested for compliance with the Pre-shipment data previously received from the manufacturer. This requirement will preclude the installation of out of specification cable segments that may have been damaged during shipment.

#### **1.4. Phases of Site Acceptance Testing for OPGW Cabling**

SAT shall be carried out link by link from FODP to FODP. SAT may be performed in parts in case of long links. The tests, checks, adjustments etc. conducted by the SI prior to offering the equipment for SAT shall be called Pre-SAT activities. The Pre-SAT activities shall be described in the installation manuals and Field Quality Plan documents.

Sag and tension of cable shall generally be as per approved sag-tension chart and during installation, sag and tension of cable shall be documented. Upon completion of a continuous cable path, all fibres within the cable path shall be demonstrated for acceptance of the cable path. Fibre Optic cable site testing minimum requirements are provided in table below.

<b>Sl. No.</b>	<b>Description</b>
<b>Fibre Optic Cable Pre-Installation Testing</b>	
1	Physical Inspection of the cable assembly for damage
2	Optical fibre continuity and fibre attenuation with OTDR
3	Fibre Optic Cable length measurement using OTDR
<b>Fibre Optic Cable Splicing Testing</b>	
1	Per splice bi-directional average attenuation with OTDR
2	Physical inspection of splice box/enclosure for proper fibre / cable routing techniques
3	Physical inspection of sealing techniques, weatherproofing, etc.
<b>Fibre Optic Cable Commissioning Testing</b>	
1	End to End (FODP to FODP) bi-directional average attenuation of each fibre at 1310 nm and 1550 nm by OTDR.
2	End to End (FODP to FODP) bi-directional average attenuation of each fibre at 1310 nm and 1550 nm by OTDR.
3	Bi-directional average splice loss by OTDR of each splice as well as for all splices in the link (including at FODP also).

<b>Sl. No.</b>	<b>Description</b>
4	Proper termination and labelling of fibres & fibre optic cables at FODP as per approved labelling plan.

*Table 123: Testing Requirements for OPGW FO Cable*

## Annexure VI - Acceptance Test Formats

The PMA will work in-line with the agreed execution schedule during the installation of Fibre, Electronics, Network Equipment, NOC at the field level. The PMA needs to test and certify each location where electronics and network equipment is installed for its operations and acceptance. The below formats are indicative only.

**Notes:** Necessary testing equipment required to meet standards compliance will be provided by the SI. After completion of the testing for each site, PMA need to submit the report in prescribed format to the PMU.

### 1. Test format 1: Electronics & Network Equipment testing & certification

Test Period	From:	To:	Remarks
Name of District			
PoP Name:	Latitude:	Longitude:	
Testing Requirements	@ 1310 nm	@ 1550 nm	
Cable Attenuation per km (dB)			
Total Physical Cable Length (km)			
Splice Loss Mean Value (dB)			
Total Number of Splices			
Maximum Connectors Loss (dB)			
Total Number of Connectors			
Total Section Loss (dB)			
Test Period			
Total route length of fibre cable laid from [name of the PoP] to [name of the PoP]	_____ kms		
Total fibre cable length tested	_____ kms		
No. of Street boxes	_____ Nos		

Name, Signature & Seal of the SI Official:

(Accepted / Rejected)

Date:

Name, Signature & Seal of PMA Official

Date:

**2. Test format 2: Electronics & Network Equipment testing & certification**

1. The End to End testing from POP to POP shall be carried out using Power meter/source and with OTDR after splicing Optical Fibre Cable
2. The average attenuation (dB/Km) for cable shall be recorded in the given format:
  - a. Tested Length : \_\_\_\_\_ Km
  - b. Total loss on the length : \_\_\_\_\_ dB
  - c. Average Attenuation per Km. : \_\_\_\_\_ dB/Km
  - d. Fibre length used : \_\_\_\_\_ Km
  - e. Net loss for Fibre at FDMS : \_\_\_\_\_ dB
3. End to end Testing shall be done in one direction only for the two wavelengths i.e. 1310 nm & 1550 nm from POP to POP side using Power meter and source. The Fibre connected to each port of the DWDM shall also be tested using the OTDR and the traces obtained shall be recorded for future reference.
4. The SI shall be responsible for co-ordination for conducting this test.
5. After carrying out this test, the respective PoP shall be detected in the NMS of NOC and shown as active at the NOC implemented by the SI as part of this RfP. SI shall share the list of PoPs in each district which have gone active.

**3. Test Format 3: End to End Testing of Route from PoP to PoP**

1. The End to End testing of the Fibre Cable route from the PoP to PoP shall be done by measuring the receive power at each PoP location using the power meter and source. Thus total attenuation would be recorded.
2. The attenuation shall be tested from PoP to PoP in one direction only for two wavelengths 1310 nm and 1550 nm.
3. The tests shall be carried on the fibre connected to each of utilized ports.
4. The test results shall be recorded in the format given in the following table. Separate sheet shall be prepared for each port.
5. Specifications: The total maximum attenuation from PoP to PoP at each location should be about 25 dB.
6. The fibre connected to each port shall also be tested using the OTDR and the traces obtained shall be recorded for future reference.

**4. Sample Test Format 4: NOC Active Components Testing**

SI No.	Test Parameter	PMA Remarks
1.	After completion of the installation work, the complete system shall be tested for H/W and S/W functions and features. SI will carry out this work. Thereafter, SI along with the representative from PMA shall carry out the Acceptance tests to prove performance of the different equipment, sub-system, and the overall installation to the entire satisfaction of the Authority	
2.	SI shall submit sufficiently in advance before the start of the acceptance tests, a list of all the acceptance test and procedures, it proposes to conduct to demonstrate that the system satisfies all the requirements of the specifications. Authority shall have the right to propose modifications or additions to tests or measuring	
3.	As a part of the acceptance tests, it shall be checked that: <ul style="list-style-type: none"> <li>- All documentation should be supplied &amp; fully updated.</li> <li>- All hardware and software items are in perfect working order at the time of testing.</li> <li>- Acceptance tests, including stability test as defined will have to be completed to the full satisfaction of the Authority.</li> </ul>	

**Volume- II**

SI No.	Test Parameter	PMA Remarks
	- All the network elements & route shall be brought in the NMS with complete testing of FCAPS functionality.	
4.	- Testing of the link engineering calculations along with link margins If the system permits - All the link margin calculations shall be done based on EOL of electronics.	
5.	- Return Loss shall be at least 40 dB - 4dB end to end OSNR margin - Per span margin shall be more than or equal to 4 dB - Auto shut down of laser & power amplifier - System should support Automatic Level control, Automatic Gain control, and Automatic equalization of the links for per channel addition/deletion.	
6.	- Regarding NMS functionality the performance management capability to be available on per channel basis in addition to line side. - Derived Power supply failure alarm - Loss of input at Optical Add/Drop multiplex equipment - Input channel failure Optical Add/Drop multiplex equipment. - Hardware mismatch alarm - Loss of Supervisory Channel	

**5. Sample Test Format 5: OFC & Accessories**

**A. OFC & Accessories**

SI No.	Item	Length/Qty installed	Remarks
	48F OFC		
	Accessories		

**B. Splice Details**

1. Section Identity/No:- \_\_\_\_\_
2. Section Length: \_\_\_\_\_
3. Splice No.:- \_\_\_\_\_

Tube Colour	Fibre Colour	Fibre No.	Splice loss @1310 nm	Splice loss @1550 nm
		1		
		....		
		48		

**Name, Signature & Seal of the SI Official:**

**(Accepted / Rejected)**

**Date:**

**Name, Signature & Seal of PMA Official**

**Date:**

**Note: Splice Loss Measurement using OTDR**

1. The fibre under test is connected to the OTDR which directly displays the splice loss after suitably the markers. The observations shall be recorded for both the windows i.e. 1310 nm and 1550 nm.
2. For the splice(s) within the Fibre Cable section (in cases where the Fibre Cable section is more than length) the splice loss shall be measured for all the 48 fibres. The splice no. shall be counted from towards the nearest POPs. The test results shall be recorded in the format given below
3. Specification: Max Splice Loss 0.05 dB for one fibre per splice for straight/branch joints.

**6. Sample Test Format 6: Attenuation Test for Fibre Cable Section in the POP using Power Meter (Power at each fibre)**

1. Section Identity/No:- \_\_\_\_\_
2. Section Length: \_\_\_\_\_
3. Transmit Power.:- \_\_\_\_\_

Fibre No.	Testing @ 1310 nm			Testing @ 1550 nm		
	Level at Rec end (PRx)	Loss(in dB) A= PTx - PRx	Attenuation per Km (in dB/Km)	Level at Rec end (PRx)	Loss(in dB) A= PTx - PRx	Attenuation per Km (in dB/Km)
1						
....						
48						

**Name, Signature & Seal of the SI Official:**

**(Accepted / Rejected)**

**Date:**

**Name, Signature & Seal of PMA Official**

**Date:**

**Note:-**

1. Carry out total section attenuation loss as mentioned in table above.
2. All the cables should meet the standard for both the wavelength i.e.1310 nm and 1550 nm as per given above i.e. less than 0.43 dB/Km for 1310 nm and 0.30 dB/km.for1550 nm.
3. Connect standard optical source with 1310 nm and 1550 nm at particular level (say P1 dBm) at the fibre. Measure with power meter the power at the other End of the fibre (say P2 dBm.) Thus, of the fibre = (P1 - P2) dB.
4. Specifications:
  - a. At 1310nm: Total Link Loss  $\leq 0.36 \text{ dB/km} \times \text{Section Length} + (0.05 \text{ dB/Splice}) \times (\text{No. of Splice}) + 0.5 \text{ dB} \times \text{No. of Connectors} + \text{splitter loss}$
  - b. At 1550nm: Total Link Loss  $\leq 0.21 \text{ dB/km} \times \text{Section Length} + (0.05 \text{ dB/Splice}) \times (\text{No. of Splice}) + 0.5 \text{ dB} \times \text{No. of Connectors}$
5. All the 48 Fibres of the Fibre Cable shall be tested with the pigtail spliced to each fibre one by one and the test readings as per the table below.
6. Attenuation test shall also be taken with OTDR at 1550nm and 1310nm and printout for each fibre and the test window shall be obtained.

**Preparation of OTDR Traces Report**

1. This method uses an optical time-domain reflectometer (OTDR). Unlike a Power Meter, the OTDR can identify and locate the position of each component in the network. The OTDR will reveal splice loss, connector loss and reflectance, and the total end to end loss.

## Volume- II

2. For End-to-End measurements including joint enclosures must be carried out to document the characterization of the joint loss and the total link loss. The OTDR measurement must be conducted upstream

3. Carry out OTDR measurements and take traces taken on all wavelengths (1310 nm / 1550 nm). Soft copy of this report needs to be made available for updating in Test reports

### 7. Sample Commissioning Certificate Format

No.: \_\_\_\_\_

Dated: \_\_\_\_\_

District: \_\_\_\_\_

The OF cable network laid under the Kerala Fibre Optic Network project for the District as listed below is hereby declared as commissioned as on <date>. The names of the institutions and the details of the PoP and OF cable network being commissioned are given in the tables below

#### A. PoP Details in the District

SI No.	Name of the PoP	Router (make, model)	OLT (make, model)	FDMS details	Remarks

#### B. Details of Institutions connected

SI No.	Name of Connected Institution	PoP from which it is connected	ONT (make, model)

#### C. OFC Network details

SI No.	Parameter	Qty	UoM	Remarks
1.	Total Institutions in the district			
2.	Total Connected Institutions in the district			
3.	Total Institutions yet to be connected in the district			
4.	Total OFC length – 48F			
5.	Total OFC length – 4F			
6.	Total No. of Street boxes			

**Name, Signature & Seal of PMA Official**

**Date:**

## Annexure VII - GIS Data Format

The GIS data should be generated in the following format for integration and harmonization with Kerala State Spatial Data Infrastructure (KSDI)

Datum	<b>WGS 84</b>
Projection	<b>UTM Zone 43 North</b>
Metadata	<b>NSDI Metadata 2.0 (template is attached to this mail)</b>
Attributes	<b>All attributes should be in expanded format</b>
Vector Data Sharing File Format	<b>Shapefile / Geodatabase</b>
Raster Data Sharing File Format	<b>IMG/GeoTiff</b>
Web service	<b>WFS and WCS (OGC Services)</b>

Table 124: KSDI Data Format

The Meta Data Format shall be as given below.

SI No.	Parameter	Value
<b>(1) Data identification information</b>		
1	Name of the Dataset :	
2	Name of the Data :	
3	Theme :	
4	Keywords :	
5	Access Constraints :	
6	Use Constraints :	
7	Purpose of Creating Data :	
8	Data Type :	
<b>(2) Citation information</b>		
9	Data Prepared by :	
10	Original Source :	
11	Source Scale and Date :	
12	Mapping year :	
13	Digitizing year :	
14	Survey year :	
15	Lineage :	
16	Associated Project preparing the data :	
17	Associated Publications :	
18	Email :	
19	Affiliation :	



**Volume- II**

SI No.	Parameter	Value
20	Corporate Name :	
21	Corporate Address :	
<b>(3) Contact information</b>		
22	Contact Person :	
23	Organization :	
24	Mailing Address :	
25	City :	
26	Country :	
27	Telephone No :	
28	Fax	
29	Email	
<b>(4) Language information</b>		
30	Language	
<b>(5) Dataset topic category information</b>		
31	MD_Metadata.identification Info- MD_DataIdentification.topic Category :	
<b>(6) Coverage information</b>		
32	Coverage.x.min :	
33	Coverage.x.max :	
34	Coverage.y.min :	
35	Coverage.y.max :	
36	Coverage.t.late :	
37	Coverage.t.early :	
38	Coverage.PlaceName :	
39	Coverage.PeriodName :	
40	Coverage.spatial.resolution :	
41	Coverage.spatial.georeference :	
42	Coverage.spatial.aggregation :	
43	Coverage.temporal.precision :	
44	Coverage.temporal.interval :	
45	Coverage.temporal.aggregation :	
46	Coverage.note :	
47	Coverage.Alternative Metadata :	
<b>(7) Image format</b>		
48	Name of the Satellite :	
49	Sensor :	
50	Path :	
51	Row :	

**Volume- II**

<b>SI No.</b>	<b>Parameter</b>	<b>Value</b>
52	Image Acquired From :	
53	Date and Time of Image :	
54	File Format :	
55	Bits per Pixel :	
56	Spatial Resolution :	
57	Spatial Resolution Unit :	
58	Number of Bands :	
59	Number of Rows :	
60	Number of Cols :	
61	Purchased or Obtained on Exchange Basis:	
<b>(8) Abstract data information</b>		
62	MD_Metadata.identification Info :	
<b>(9) Metadata date stamp</b>		
63	MD_Metadata.date Stamp :	
<b>(10) Online resource</b>		
64	On-line resource :	
<b>(11) Data Quality</b>		
65	Logical_Consistency_Report :	
66	Completeness_Report :	
67	Process_Description :	
68	Process_Date :	
69	Source_Originator :	
70	Source_Publication_Date :	
71	Source_Title :	
72	Source_Online_Linkage :	
73	Source_Scale_Denominator :	
74	Type_of_Source_Media :	
75	Source_Time_Period_of_Content :	
76	Source_Currentness_Reference :	
77	Source_Citation_Abbreviation :	
78	Source_Contribution [If data assessments performed : Attribute_Accuracy_Report (if applicable)] :	
79	Horizontal_Positional_Accuracy_Report (if applicable) :	
80	Vertical_Positional_Accuracy_Report (if applicable) :	
<b>(12) Quicklook</b>		
81	Quicklook :	

*Table 125: Meta Data Format*